

Turcon® Excluder® 5



Double-acting

Rubber-energized Double-acting Scraper

Material:

Turcon®, Zurcon® and Elastomer





Turcon® Excluder® 5*



Description

Turcon® Excluder® 5 is a patented double-acting scraper with scraper lip and sealing lip, positioned back-to-back. The scraper is installed with an O-Ring as elastic energizing element in one groove. The scraper function is performed by the Excluder® 5 Turcon® element. The O-Ring maintains the pressure of the scraper lips against the sliding surface and can compensate deflections of the piston rod.

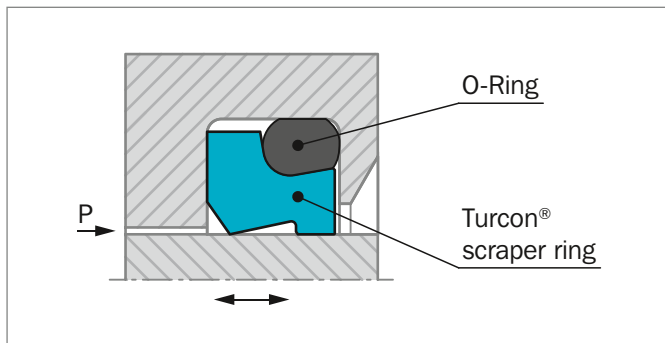

Figure 175: Turcon® Excluder® 5

Excluder® 5 has two functions:

- Scrape contaminants from the retracting piston rod to protect the system from soiling
- Hold back the residual oil film on the extending piston rod on the medium side.

Excluder® 5 is used in conjunction with our rod seals Turcon® Stepseal® 2K, Turcon® VL Seal® or Zurcon® Rimseal, i.e. seals with a hydrodynamic back-pumping function. In contrast to Excluder® 2, they are used particularly for heavy-duty applications such as in construction machinery, presses, etc.

ADVANTAGES

- Outstanding sliding properties
- Stick-slip-free, no sticking (Turcon® material)
- Tough scraper for heavy-duty operation
- Can compensate for deflections of the piston rod or plunger
- Very good scraping effect even against firmly adhered dirt, etc.
- Very good scraping effect from the inside against the residual oil film adhering to the surface of the piston rod
- Identical installation with that of the Zurcon® Excluder® 500
- Very high resistance to hydraulic media

- Available for all diameters up to 2,600 mm (Turcon®), up to 2,200 mm (Zurcon® Z53/Z54).
- ISO 6195 Type D installation dimensions from diameter 40 mm

OPERATING CONDITIONS

Speed:	Up to 15 m/s for Turcon® materials Up to 2 m/s for Zurcon® materials
Temperature:	-45 °C to +200 °C (Turcon®) -45 °C to +110 °C (Zurcon® Z53/Z54) -60 °C to +80 °C (Zurcon® Z80) depending on O-Ring material
Media:	Mineral oil-based hydraulic fluids, flame retardant hydraulic fluids, environmentally friendly hydraulic fluids (bio-oils), phosphate ester, water, air and others, depending on the scraper and O-Ring material compatibility.

IMPORTANT NOTE

The above data are maximum values and cannot be used at the same time, e.g. the maximum operating speed depends on material type, pressure, temperature and gap value. Temperature range also depends on media.

INSTALLATION INSTRUCTIONS

Excluder® 5 scrapers can be installed in split and closed grooves installation dimensions, see Table 165.

Installation in closed grooves depends on the rod diameter, profile cross-section of the scraper and on the cross section of the corresponding O-Ring, see Table 167.

Table 165: Installation in Closed Grooves

Turcon® Excluder® 5 Series No.	Rod Diameter d_N	O-Ring Cross Section d_2
WE50	> 30.0	2.62
WE51	> 40.0	2.62
WE52	> 70.0	3.53
WE53	> 100.0	5.33
WE54	> 140.0	7.00
WE55	> 180.0	8.40

* Patent-No. EP 023 5568



RECOMMENDED MATERIALS

The following material combinations have proven effective for most applications:

Turcon® Excluder® 5 in Turcon® M12

All round material for light to heavy hydraulic applications with linear, short stroke or helical movements in mineral oils, flame retardant hydraulic fluids, phosphate ester, bio-oils or fluids having low lubricating properties:

O-Ring: NBR 70 Shore A N
 FKM 70 Shore A V

Set code: M12N or M12V

Turcon® Excluder® 5 in Turcon® T46

For medium to heavy applications with linear movements in mineral oils and other media with good lubrication:

O-Ring: NBR 70 Shore A N
 FKM 70 Shore A V

Set code: T46N or T46V

For specific applications, all Turcon® materials are available.

Other material combinations are listed in Table 166.

Table 166: Turcon® and Zurcon® Materials for Excluder® 5

Material, Applications, Properties	Code	O-Ring Material Shore A	Code	O-Ring Operating Temp. * °C	Mating Surface Material	Speed max. m/s
Turcon® M12 First material choice for linear motion Overall improved properties For new constructions and updating For all commonly applied hydraulic fluids including fluids with low lubrication performance Lowest friction and best sliding properties Lowest wear on scrapers Improved absorption of abrasive contaminants Low wear or abrasion of counter surface BAM tested Mineral fiber and Additives filled Color: Dark gray	M12	NBR 70	N	-30 to +100	Steel Steel, hardened Steel, chrome plated (rod) Cast iron Stainless steel Titanium	15
		NBR 70 Low temp.	T	-45 to +80		
		FKM 70	V	-10 to +200		
Turcon® T40 For lubricating and non-lubricating fluids High frequency and short strokes Water hydraulics Surface texture is not suitable for gas sealing Carbon fiber filled Color: Gray	T40	NBR 70	N	-30 to +100	Steel Steel, chrome plated (rod) Cast iron Stainless steel Aluminum	15
		NBR 70 Low temp.	T	-45 to +80		
		FKM 70	V	-10 to +200		
		EPDM 70	E**	-45 to +145		

Table continues on next page



Material, Applications, Properties	Code	O-Ring Material Shore A	Code	O-Ring Operating Temp. * °C	Mating Surface Material	Speed max. m/s
Turcon® T46 For lubricated hydraulics in linear motion High compressive strength High extrusion resistance Very good sliding and wear properties BAM tested Bronze filled Color: Light to dark brown, which may have variations in shading.	T46	NBR 70	N	-30 to +100	Steel, hardened	15
		NBR 70 Low temp.	T	-45 to +80	Steel, chrome plated (rod) Cast iron	
		FKM 70	V	-10 to +200		
Zurcon® Z53*** For mineral oil based fluids Linear and slowly turning movements Very high abrasion and extrusion resistance For counter surface with rougher surface finish More difficult to install Limited chemical resistance Max. working temperature 110 °C Cast polyurethane Color: Yellow to light-brown	Z53	NBR 70	N	-30 to +100	Steel	2
		NBR 70 Low temp.	T	-45 to +80	Steel, hardened Steel chrome plated (rod) Cast iron Ceramic coating Stainless steel	
Zurcon® Z54*** For mineral oil based fluids High abrasion resistance For counter surface with rougher surface finish Good extrusion resistance Limited chemical resistance Max. working temperature 110 °C Cast polyurethane Color: Turquoise	Z54	NBR 70	N	-30 to +100	Steel	1
		NBR 70 Low temp.	T	-45 to +80	Steel, hardened Steel, chrome plated (rod) Cast iron Stainless steel Aluminum Ceramic coating	
Zurcon® Z80 For lubricating and non-lubricating fluids Water based fluids, air and gases Dry air pneumatics High abrasion and extrusion resistance For service in abrasive conditions and media with particles Good chemical resistance Limited temperature capability (-60 to +80 °C) UHMWPE (Ultra High Molecular Weight Polyethylene)	Z80	NBR 70	N	-30 to (+100)	Steel	2
		NBR 70 Low temp.	T	-45 to +80	Steel, chrome plated (rod) Stainless steel	
		EPDM 70	E**	-45 to (+145)	Aluminum Ceramic coating	

* The O-Ring Operation Temperature is only valid in mineral hydraulic oil (except EPDM).

** Material not suitable for mineral oils.

*** Max. diameter 2,200 mm

BAM: Tested by "Bundesanstalt Materialprüfung, Germany".

□ Highlighted materials are recommended.



■ Installation Recommendation

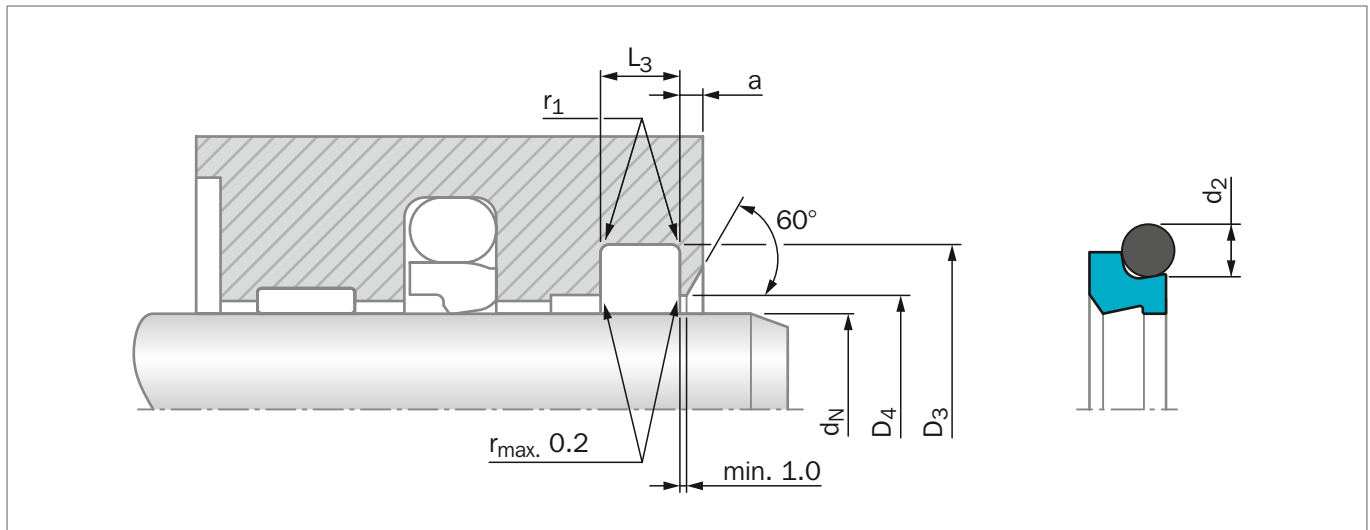

Figure 176: Installation Drawing

Table 167: Installation Dimensions – Standard Recommendations

Series No.	Rod Diameter d_N f8/h9		Groove Diameter D_3 H9	Groove Width L_3 +0.2/-0.0	Bore Diameter D_4 H11	Step Width a_{min}	Radius r_1 max	O-Ring Cross Section d_2
	Standard Application	Available Range						
WE50	19 – 39.9	19 – 100.0	$d_N + 7.6$	4.2	$d_N + 1.5$	3.0	0.8	2.62
WE51	40 – 69.9	30 – 200.0	$d_N + 8.8$	6.3	$d_N + 1.5$	3.0	1.0	2.62
WE52	70 – 139.9	50 – 360.0	$d_N + 12.2$	8.1	$d_N + 2.0$	4.0	1.0	3.53
WE53	140 – 399.9	100 – 650.0	$d_N + 16.0$	9.5	$d_N + 2.5$	5.0	1.5	5.33
WE54	400 – 649.9	200 – 650.0	$d_N + 24.0$	14.0	$d_N + 2.5$	8.0	1.5	7.00
WE55	650 – 999.9	400 – 999.9	$d_N + 27.3$	16.0	$d_N + 2.5$	10.0	2.0	8.40
WE55X	1,000 - 2,600		$d_N + 27.3$	16.0	$d_N + 2.5$	10.0	2.0	8.40

ORDERING EXAMPLE

Turcon® Excluder® 5 complete with O-Ring, standard application:

Series:	WE51 from Table 167
Rod Diameter:	$d_N = 50.0$ mm
TSS Part No.:	WE5100500 from Table 168

Select the material from Table 166. The corresponding code numbers are appended to the TSS Part No. Together these form the TSS Article Number. The TSS Article Number for all intermediate sizes can be determined by following the example:

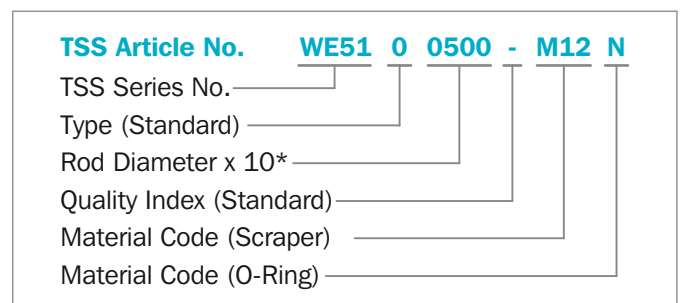

* For diameters $d_N \geq 1,000.0$ mm multiply only by factor 1.
 Example: WE55 for diameter $d_N = 1,200.0$ mm
 TSS Article No.: WE55X1200-M12N



Table 168: Installation Dimensions / TSS Part No.

Rod Dia.	Groove Dia.	Groove Width	TSS Part No.	O-Ring Size	Rod Dia.	Groove Dia.	Groove Width	TSS Part No.	O-Ring Size
d_N f8/h9	D_3 H9	L_3 +0.2			d_N f8/h9	D_3 H9	L_3 +0.2		
19.0	26.6	4.2	WE5000190	21.89 x 2.62	125.4	137.6	8.1	WE5201254	129.77 x 3.53
20.0	27.6	4.2	WE5000200	21.89 x 2.62	130.0	142.2	8.1	WE5201300	136.12 x 3.53
22.0	29.6	4.2	WE5000220	25.07 x 2.62	135.0	147.2	8.1	WE5201350	139.29 x 3.53
25.0	32.6	4.2	WE5000250	28.24 x 2.62	140.0*	152.2	8.1	WE5201400	145.64 x 3.53
28.0	35.6	4.2	WE5000280	29.82 x 2.62	140.0*	156.0	9.5	WE5301400	145.42 x 5.33
30.0	37.6	4.2	WE5000300	32.99 x 2.62	140.5	156.5	9.5	WE5301405	145.42 x 5.33
32.0	39.6	4.2	WE5000320	34.59 x 2.62	150.0	166.0	9.5	WE5301500	151.77 x 5.33
35.0	42.6	4.2	WE5000350	37.77 x 2.62	153.0	169.0	9.5	WE5301530	158.12 x 5.33
36.0	43.6	4.2	WE5000360	37.77 x 2.62	155.0	171.0	9.5	WE5301550	158.12 x 5.33
40.0*	48.8	6.3	WE5100400	44.12 x 2.62	160.0*	172.2	8.1	WE5201600	164.69 x 3.53
42.0	50.8	6.3	WE5100420	45.69 x 2.62	160.0*	176.0	9.5	WE5301600	164.47 x 5.33
45.0*	53.8	6.3	WE5100450	48.90 x 2.62	165.0	181.0	9.5	WE5301650	170.82 x 5.33
48.0	56.8	6.3	WE5100480	52.07 x 2.62	170.0	186.0	9.5	WE5301700	177.17 x 5.33
50.0*	58.8	6.3	WE5100500	53.64 x 2.62	175.0	191.0	9.5	WE5301750	177.17 x 5.33
52.0	60.8	6.3	WE5100520	55.25 x 2.62	180.0*	192.2	8.1	WE5201800	183.74 x 3.53
55.0	63.8	6.3	WE5100550	58.42 x 2.62	180.0*	196.0	9.5	WE5301800	183.52 x 5.33
56.0*	64.8	6.3	WE5100560	59.99 x 2.62	188.2	204.2	9.5	WE5301882	189.87 x 5.33
60.0	67.6	4.2	WE5000600	63.17 x 2.62	190.0	206.0	9.5	WE5301900	196.22 x 5.33
60.0	68.8	6.3	WE5100600	63.17 x 2.62	200.0*	212.2	8.1	WE5202000	202.79 x 3.53
63.0*	71.8	6.3	WE5100630	66.34 x 2.62	200.0*	216.0	9.5	WE5302000	202.57 x 5.33
65.0	73.8	6.3	WE5100650	67.95 x 2.62	220.0*	232.2	8.1	WE5202200	221.84 x 3.53
70.0*	78.8	6.3	WE5100700	72.69 x 2.62	220.0*	236.0	9.5	WE5302200	221.62 x 5.33
70.0*	82.2	8.1	WE5200700	75.79 x 3.53	240.0	256.0	9.5	WE5302400	247.02 x 5.33
75.0	87.2	8.1	WE5200750	78.97 x 3.53	250.0*	262.2	8.1	WE5202500	253.59 x 3.53
80.0*	88.8	6.3	WE5100800	82.22 x 2.62	250.0*	266.0	9.5	WE5302500	253.37 x 5.33
80.0*	92.2	8.1	WE5200800	85.32 x 3.53	260.0	276.0	9.5	WE5302600	266.07 x 5.33
85.0	97.2	8.1	WE5200850	88.49 x 3.53	270.0	286.0	9.5	WE5302700	278.77 x 5.33
90.0*	98.8	6.3	WE5100900	94.92 x 2.62	280.0*	292.2	8.1	WE5202800	278.99 x 3.53
90.0*	102.2	8.1	WE5200900	94.84 x 3.53	280.0*	296.0	9.5	WE5302800	278.77 x 5.33
92.5	104.7	8.1	WE5200925	98.02 x 3.53	300.0	316.0	9.5	WE5303000	304.17 x 5.33
95.0	107.2	8.1	WE5200950	101.19 x 3.53	320.0*	332.2	8.1	WE5203200	329.79 x 3.53
100.0*	108.8	6.3	WE5101000	101.27 x 2.62	320.0*	336.0	9.5	WE5303200	329.57 x 5.33
100.0*	112.2	8.1	WE5201000	104.37 x 3.53	330.0	346.0	9.5	WE5303300	329.57 x 5.33
105.0	117.2	8.1	WE5201050	110.72 x 3.53	350.0	366.0	9.5	WE5303500	354.97 x 5.33
110.0*	118.8	6.3	WE5101100	113.97 x 2.62	360.0*	372.2	8.1	WE5203600	355.19 x 3.53
110.0*	122.2	8.1	WE5201100	113.89 x 3.53	360.0*	376.0	9.5	WE5303600	365.00 x 5.30
115.0	127.2	8.1	WE5201150	120.24 x 3.53	380.0	396.0	9.5	WE5303800	380.37 x 5.33
120.0	132.2	8.1	WE5201200	123.42 x 3.53	400.0	424.0	14.0	WE5404000	405.26 x 7.00
125.0*	133.8	6.3	WE5101250	126.67 x 2.62	440.0	464.0	14.0	WE5404400	443.36 x 7.00
125.0*	137.2	8.1	WE5201250	129.77 x 3.53	450.0	474.0	14.0	WE5404500	456.06 x 7.00



Rod Dia.	Groove Dia.	Groove Width	TSS Part No.	O-Ring Size
d_N f8/h9	D_3 H9	L_3 +0.2		
480.0	504.0	14.0	WE5404800	481.38 x 7.00
500.0	524.0	14.0	WE5405000	506.86 x 7.00
560.0	584.0	14.0	WE5405600	557.66 x 7.00
600.0	624.0	14.0	WE5406000	608.08 x 7.00
650.0	677.3	16.0	WE5506500	662 x 8.40
680.0	707.3	16.0	WE5506800	692 x 8.40
700.0	727.3	16.0	WE5507000	712 x 8.40
750.0	777.3	16.0	WE5507500	762 x 8.40
800.0	827.3	16.0	WE5508000	812 x 8.40
850.0	877.3	16.0	WE5508500	862 x 8.40
900.0	927.3	16.0	WE5509000	912 x 8.40
950.0	977.3	16.0	WE5509500	962 x 8.40
1,000.0	1,027.3	16.0	WE55X1000	1,012 x 8.40
1,800.0	1,827.3	16.0	WE55X1800	1,812 x 8.40
2,600.0	2,627.3	16.0	WE55X2600	2,612 x 8.40

The rod diameters in **bold** type comply with the recommendations of ISO 3320.

* Installation in grooves according to ISO 6195 Type D