

# Zurcon® Scraper DA22



---

Double-acting

---

**Material:**  
Zurcon®

---







## ■ Zurcon® Scraper DA22



### ■ Description

The scraper is a double-acting polyurethane wiper for closed groove installation. Significant improvements are achieved regarding the profile geometry and material used if compared with conventional elastomeric scrapers.

The scraper lip is designed in a particular way that it reliably scrapes off the dirt but leaves a residual oil film on the rod, which is required for correct operation. The radial squeeze is sufficient to remove particles, dust and water.

The scraping lip facing inwards is designed in a way that it assumes a sealing function even under low pressure. The static seal is achieved by a tight radial fit between the scraper body and the groove.

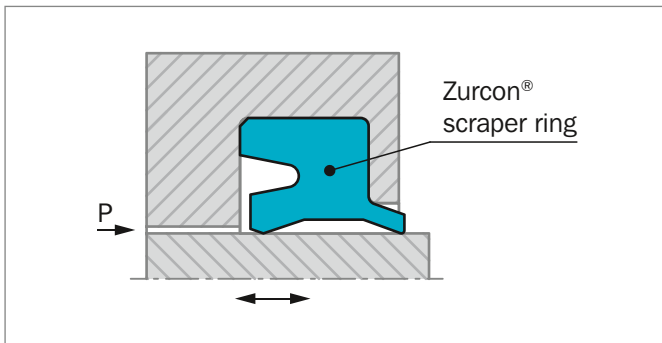

Figure 198: Scraper DA22

### ADVANTAGES

- Good scraping effect
- Wear resistant, long service life
- Retaining residual oil film
- Standard elements for standardized installation grooves.

### APPLICATION EXAMPLES

Due to the outstanding wiping capacities, DA22 scraper is recommended wherever there are dusty and humid conditions and especially for the following applications:

- ISO standard cylinders
- Hydraulic industrial cylinders
- Agriculture machinery

### OPERATING CONDITIONS

<b>Pressure</b>	Atmospheric pressure
<b>Scraper Side:</b>	
<b>Seal Side:</b>	Pressures up to 2 MPa (20 bar) a relief bore must be provided with higher pressures
<b>Speed:</b>	Up to 1 m/s
<b>Temperature:</b>	-35 °C to +100 °C
<b>Media:</b>	Mineral oils and greases
<b>Groove Type:</b>	Split/Closed (depending on size)

### IMPORTANT NOTE

The above data are maximum values and cannot be used at the same time, e.g. the maximum operating speed depends on material type, pressure, temperature and gap value. Temperature range also depends on media.

### MATERIALS

Standard application:

Zurcon® Polyurethane: 92 Shore A

Material Code: Z201

Color: Turquoise



## ■ Installation Recommendation

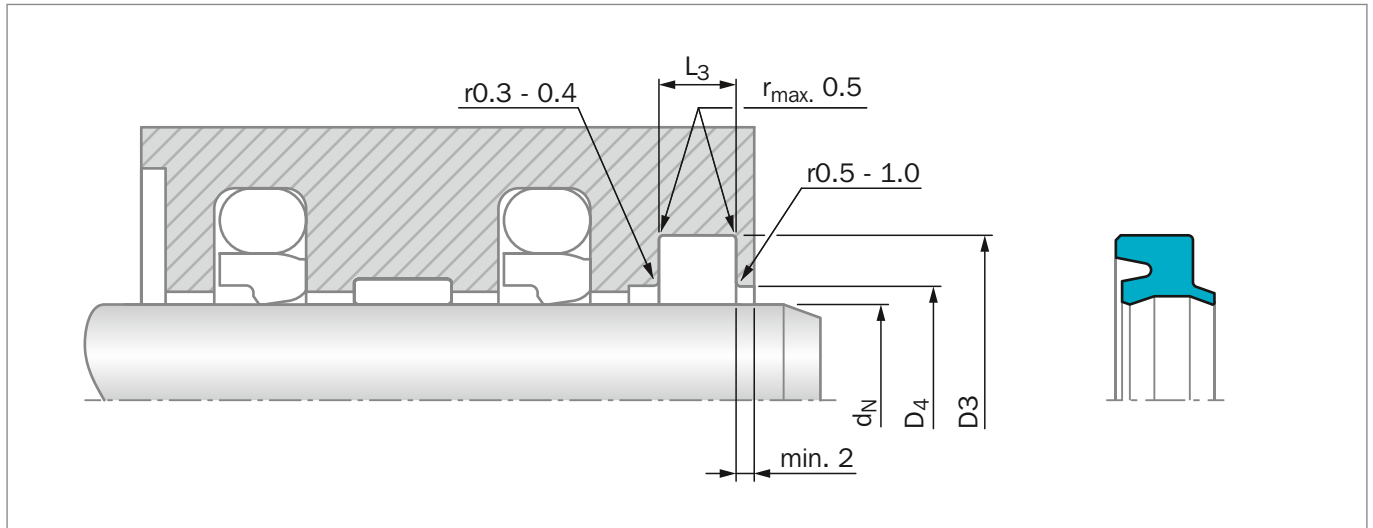

Figure 199: Installation Drawing

### ORDERING EXAMPLE

<b>Rod Diameter:</b>	$d_N = 36 \text{ mm}$
<b>Groove Diameter:</b>	$D3 = 44 \text{ mm}$
<b>Example 1</b>	
<b>TSS Part No.:</b>	WD2200360 from Table 186
<b>Material Code:</b>	Z201
<b>Old Ref. No.:</b>	Not available

<b>TSS Article No.</b>	<b>WD22 0 0360 - Z201</b>
TSS Series No.	WD22
Type (Standard)	0
Rod Diameter x 10	0360
Quality Index (Standard)	-
Material Code	Z201

Table 186: Installation Dimensions / TSS Part No.

Rod Diameter	Groove Diameter	Groove Width	Bore Diameter	TSS Part No.
$d_N$ f8/h9	D3 H9	L3 +0.2	D4 H11	
5.0	10.0	3.5	7.5	WD2200050
8.0	13.0	3.5	10.5	WD2200080
10.0	16.0	4.0	12.5	WD2200100
<b>12.0</b>	<b>18.0</b>	<b>4.0</b>	<b>14.5</b>	<b>WD2200120</b>
12.0	18.6	3.8	15.0	WD2210120
<b>14.0</b>	<b>20.0</b>	<b>4.0</b>	<b>16.5</b>	<b>WD2200140</b>
14.0	20.6	3.8	17.0	WD2210140
16.0	22.0	4.0	18.5	WD2200160
<b>18.0</b>	<b>24.0</b>	<b>4.0</b>	<b>20.5</b>	<b>WD2200180</b>
18.0	24.6	3.8	21.0	WD2210180



Rod Diameter	Groove Diameter	Groove Width	Bore Diameter	TSS Part No.
$d_N$ f8/h9	$D_3$ H9	$L_3$ +0.2	$D_4$ H11	
20.0	26.0	4.0	22.5	WD2200200
20.0	28.6	5.3	23.0	WD2210200
<b>22.0</b>	<b>28.0</b>	<b>4.0</b>	<b>24.5</b>	<b>WD2200220</b>
22.0	30.6	5.3	25.0	WD2210220
24.0	32.6	5.3	27.0	WD2210240
25.0	31.0	4.0	27.5	WD2200250
25.0	33.6	5.3	28.0	WD2210250
<b>28.0</b>	<b>36.0</b>	<b>5.0</b>	<b>31.0</b>	<b>WD2200280</b>
28.0	36.6	5.3	31.0	WD2210280
30.0	38.0	5.0	33.0	WD2200300
30.0	38.6	5.3	33.0	WD2210300
32.0	40.0	5.0	35.0	WD2200320
35.0	43.0	5.0	38.0	WD2200350
35.0	43.6	5.3	38.0	WD2210350
<b>36.0</b>	<b>44.0</b>	<b>5.0</b>	<b>39.0</b>	<b>WD2200360</b>
36.0	44.6	5.3	39.0	WD2210360
40.0	48.0	5.0	43.0	WD2200400
40.0	48.6	5.3	43.0	WD2210400
<b>45.0</b>	<b>53.0</b>	<b>5.0</b>	<b>48.0</b>	<b>WD2200450</b>
45.0	53.6	5.3	48.0	WD2210450
50.0	58.0	5.0	53.0	WD2200500
50.0	58.6	5.3	53.0	WD2210500
55.0	63.6	5.3	58.0	WD2210550
55.0	65.0	6.0	58.0	WD2200550
56.0	64.6	5.3	59.0	WD2210560
<b>56.0</b>	<b>66.0</b>	<b>6.0</b>	<b>59.0</b>	<b>WD2200560</b>
60.0	68.6	5.3	63.0	WD2210600
60.0	70.0	6.0	63.0	WD2200600
63.0	71.6	5.3	66.0	WD2210630
63.0	73.0	6.0	66.0	WD2200630
65.0	75.0	6.0	68.0	WD2200650
70.0	78.6	5.3	73.0	WD2210700
<b>70.0</b>	<b>80.0</b>	<b>6.0</b>	<b>73.0</b>	<b>WD2200700</b>
75.0	83.6	5.3	78.0	WD2210750
75.0	85.0	6.0	78.0	WD2200750
80.0	88.6	5.3	83.0	WD2210800
80.0	90.0	6.0	83.0	WD2200800
85.0	95.0	6.0	88.0	WD2200850
85.0	97.2	7.1	91.0	WD2210850
<b>90.0</b>	<b>100.0</b>	<b>6.0</b>	<b>93.0</b>	<b>WD2200900</b>
90.0	102.2	7.1	96.0	WD2210900
100.0	110.0	6.0	103.0	WD2201000



Rod Diameter	Groove Diameter	Groove Width	Bore Diameter	TSS Part No.
$d_N$ f8/h9	<b>D3</b> H9	<b>L<sub>3</sub></b> +0.2	<b>D<sub>4</sub></b> H11	
100.0	112.2	7.1	106.0	<a href="#">WD2211000</a>
110.0	122.2	7.1	116.6	<a href="#">WD2211100</a>
<b>110.0</b>	<b>125.0</b>	<b>8.5</b>	<b>114.0</b>	<b><a href="#">WD2201100</a></b>
120.0	135.0	8.5	124.0	<a href="#">WD2201200</a>
125.0	140.0	8.5	129.0	<a href="#">WD2201250</a>
<b>140.0</b>	<b>155.0</b>	<b>8.5</b>	<b>144.0</b>	<b><a href="#">WD2201400</a></b>
150.0	165.0	8.5	154.0	<a href="#">WD2201500</a>
160.0	175.0	8.5	164.0	<a href="#">WD2201600</a>
180.0	195.0	8.5	184.0	<a href="#">WD2201800</a>

The sizes in **bold** type comply with ISO 6195. Installation groove Type C.  
Up to 18 mm diameter we recommend a split groove.  
Other sizes on request.