

Scraper WRM



Single-acting

Material:
NBR Elastomer





■ Scraper WRM



■ Description

Scraper rings are essential components of any hydraulic or pneumatic equipment.

These are protection components for axial moving rods: they ensure that foreign matter is not introduced into the system, avoiding costly wear and damage to all the internal components including seals.

WRM scrapers are manufactured in nitrile elastomer with precision machined wiper lip, which produces a very effective wiping action.

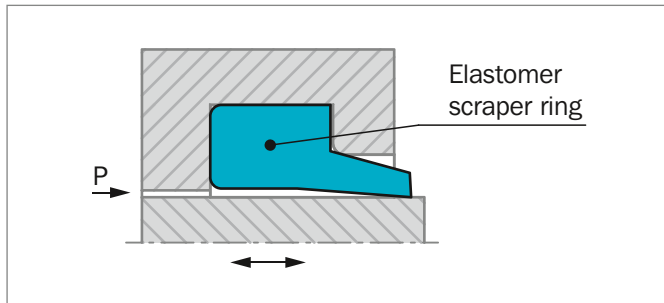

Figure 203: Scraper WRM

ADVANTAGES

- Space-saving construction
- Low cost, economical solution
- Simple, easy-construction groove
- Easy installation and removal without tools

APPLICATION EXAMPLES

Due to their outstanding wiping capacities WRM scrapers are recommended wherever there are dusty and humid conditions and especially for the following applications:

- Valve spindles
- Slide valves
- Hydraulic cylinders
- Agriculture machinery

OPERATING CONDITIONS

Speed:	Up to 1 m/s
Temperature:	-30 °C to +110 °C
Media:	Mineral oil based hydraulic fluids, polyglycol-water emulsions, water-oil emulsions
Groove Type:	Closed

IMPORTANT NOTE

The above data are maximum values and cannot be used at the same time, e.g. the maximum operating speed depends on material type, pressure, temperature and gap value. Temperature range also depends on media.

MATERIALS

Standard application

Nitrile elastomer: NBR 90 Shore A

Material Code: N9T60

Polypac Ref. code: 2790



Installation Recommendation

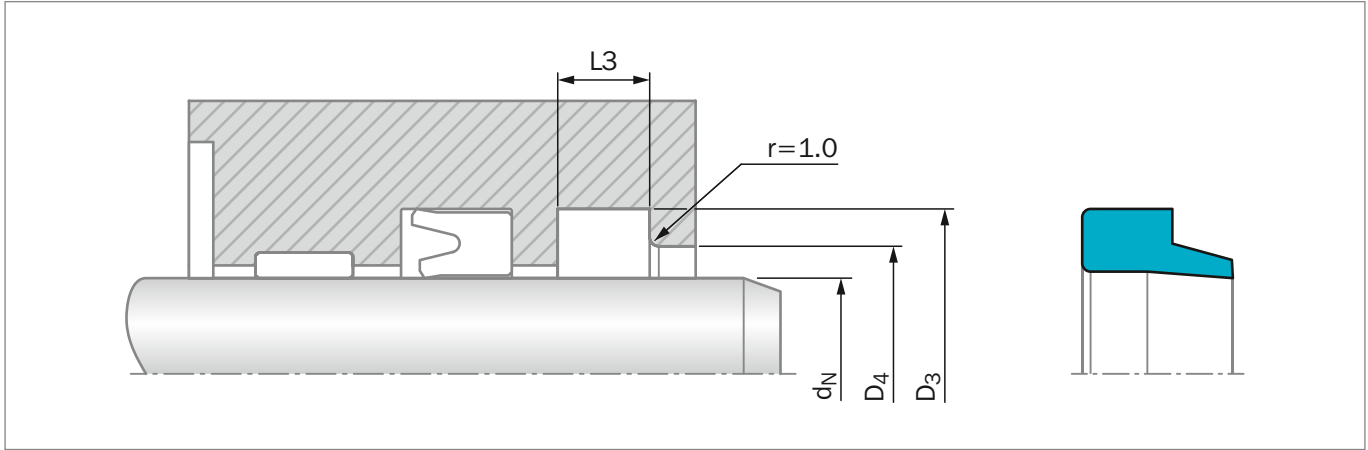

Figure 204: Installation Drawing

ORDERING EXAMPLE

Rod Diameter:	$d_N = 40 \text{ mm}$
TSS Part No.:	WAP000400 from Table 188
Material Code:	N9T60 (standard)
Polypac Ref.:	WRM 157188

TSS Article No.	WAP0 0 0400 - N9T60
TSS Series No.	WAP0
Type (Standard)	0
Rod Diameter x 10	0400
Quality Index (Standard)	-
Material Code	N9T60

Table 188: Installation Dimensions / TSS Part No.

Rod Diameter	Groove Diameter	Groove Width	Bore Diameter	TSS Part No.	Description
d_N f8/h9	D_3 H9	L_3 +0.2	D_4 +0.2		
12.0	18.6	3.8	15.0	WAP000120	WRM047070
13.0	19.6	3.8	16.0	WAP000130	WRM051074
14.0	20.6	3.8	17.0	WAP000140	WRM055078
15.0	21.6	3.8	18.0	WAP000150	WRM059082
16.0	22.6	3.8	19.0	WAP000160	WRM062087
17.0	23.6	3.8	20.0	WAP000170	WRM066094
18.0	24.6	3.8	21.0	WAP000180	WRM070094
19.0	28.6	5.3	22.0	WAP000190	WRM074110
20.0	28.6	5.3	23.0	WAP000200	WRM078110
22.0	30.6	5.3	25.0	WAP000220	WRM086118
24.0	32.6	5.3	27.0	WAP000240	WRM094125
25.0	31.6	5.3	28.0	WAP100250	WRM098122/S
25.0	33.6	5.3	28.0	WAP000250	WRM098129
26.0	34.6	5.3	29.0	WAP000260	WRM102133



Rod Diameter	Groove Diameter	Groove Width	Bore Diameter	TSS Part No.	Description
d_N f8/h9	D_3 H9	L_3 +0.2	D_4 +0.2		
27.0	35.6	5.3	30.0	WAP000270	WRM106137
28.0	36.6	5.3	31.0	WAP000280	WRM110141
30.0	38.6	5.3	33.0	WAP000300	WRM118149
31.0	41.0	6.0	34.0	WAP000310	WRM4544907
32.0	40.6	5.3	35.0	WAP000320	WRM125157
33.0	41.6	5.3	36.0	WAP000330	WRM129161
35.0	43.6	5.3	38.0	WAP000350	WRM137169
36.0	44.6	5.3	39.0	WAP000360	WRM141173
38.0	46.6	5.3	41.0	WAP000380	WRM149181
40.0	48.6	5.3	43.0	WAP000400	WRM157188
42.0	50.6	5.3	45.0	WAP000420	WRM165196
45.0	53.6	5.3	48.0	WAP000450	WRM177208
45.0	55.6	5.3	49.0	WAP100450	WRM177216
46.0	54.6	5.3	49.0	WAP000460	WRM181212
48.0	56.6	5.3	51.0	WAP000480	WRM188220
49.0	57.6	5.3	52.0	WAP000490	WRM193225
50.0	58.6	5.3	53.0	WAP000500	WRM196228
50.0*	60.6	5.3	54.0	WAP100500	WRM196236
50.8	60.9	5.8	55.5	WAP000508	WRM200237
53.0*	61.6	5.3	56.0	WAP000530	WRM208240
55.0*	63.6	5.3	58.0	WAP000550	WRM216248
55.0	65.6	5.3	59.0	WAP100550	WRM216255
60.0	68.6	5.3	63.0	WAP000600	WRM236267
63.0*	71.6	5.3	66.0	WAP000630	WRM248279
63.0	73.6	5.3	67.0	WAP100630	WRM248287
65.0	73.6	5.3	68.0	WAP000650	WRM255287
65.0	75.6	5.3	69.0	WAP100650	WRM255295
70.0*	76.0	4.3	72.0	WAP000700	WRM275299
70.0	78.6	5.3	73.0	WAP100700	WRM275307
70.0	80.6	5.3	72.0	WAP200700	WRM275314
70.0	82.6	7.1	76.0	WAP300700	WRM275322
72.0	80.6	5.3	75.0	WAP000720	WRM283317
73.0	81.6	5.3	76.0	WAP000730	WRM287318
75.0	83.6	5.3	78.0	WAP000750	WRM295326
75.0	87.2	7.1	81.0	WAP100750	WRM295345
76.5	88.7	7.1	82.5	WAP000765	WRM301348
78.0	92.2	7.1	85.0	WAP000780	WRM307362
80.0	88.6	5.3	83.0	WAP000800	WRM314346
80.0	92.6	7.1	86.0	WAP100800	WRM314362
83.0	91.6	5.3	86.0	WAP000830	WRM326358
84.0	92.0	5.3	87.0	WAP000840	WRM330362
85.0	93.6	5.3	88.0	WAP000850	WRM334366



Rod Diameter	Groove Diameter	Groove Width	Bore Diameter	TSS Part No.	Description
d_N f8/h9	D_3 H9	L_3 +0.2	D_4 +0.2		
85.0	97.2	7.1	91.0	WAP100850	WRM334381
88.0	100.2	7.1	94.0	WAP000880	WRM346393
90.0	102.2	7.1	96.0	WAP000900	WRM354401
95.0	107.2	7.1	101.0	WAP000950	WRM374421
97.0	111.0	7.1	104.0	WAP000970	WRM380437
100.0	112.2	7.1	106.0	WAP001000	WRM393440
101.0	111.0	5.3	105.0	WAP001010	WRM397437
103.0	115.2	7.1	109.0	WAP001030	WRM405452
104.0	116.2	7.1	110.0	WAP001040	WRM409457
105.0	117.2	7.1	111.0	WAP001050	WRM413460
110.0	122.2	7.1	116.0	WAP001100	WRM433480
115.0	127.2	7.1	121.0	WAP001150	WRM452500
116.0	128.2	7.1	121.0	WAP001160	WRM456504
116.0	130.2	7.1	123.0	WAP101160	WRM456511
118.0*	130.2	7.1	124.0	WAP001180	WRM464511
120.0	128.6	5.3	123.0	WAP001200	WRM472504
120.0	132.2	7.1	126.0	WAP101200	WRM472519
121.0*	131.0	5.3	125.0	WAP001210	WRM476515
125.0	137.2	7.1	131.0	WAP001250	WRM492539
127.0	135.6	5.3	132.0	WAP001270	WRM500531
127.0	139.2	7.1	133.0	WAP101270	WRM500550
130.0	142.2	7.1	136.0	WAP001300	WRM511559
135.0	147.2	7.1	141.0	WAP001350	WRM531578
135.0	149.2	7.1	142.0	WAP101350	WRM531582
140.0	152.2	7.1	146.0	WAP001400	WRM551598
140.0	155.2	10.1	147.0	WAP101400	WRM551610
145.0	157.2	7.1	151.0	WAP001450	WRM570618
146.0*	158.0	6.3	152.0	WAP001460	WRM575622/1
146.05	158.25	7.1	152.05	WAP001461	WRM575622
150.0*	162.2	7.1	156.0	WAP001500	WRM590637
155.0	169.2	7.1	162.0	WAP001550	WRM610664
160.0	168.6	5.3	163.0	WAP001600	WRM629661
160.0	175.2	10.1	168.0	WAP101600	WRM629688
165.0	173.6	5.3	168.0	WAP001650	WRM649681
165.0	177.2	7.1	171.0	WAP101650	WRM649698
170.0	180.6	5.3	174.0	WAP001700	WRM669708
170.0	185.2	10.1	178.0	WAP101700	WRM669728
171.0	183.0	6.3	176.0	WAP001710	WRM673720
175.0	189.2	7.1	182.0	WAP001750	WRM688744
180.0	195.2	10.1	188.0	WAP001800	WRM708767
187.0*	195.6	5.3	190.0	WAP001870	WRM736768
196.0	210.2	7.1	203.0	WAP001960	WRM771826



Rod Diameter	Groove Diameter	Groove Width	Bore Diameter	TSS Part No.	Description
d_N f8/h9	D_3 H9	L_3 +0.2	D_4 +0.2		
197.0	219.0	6.3	202.0	WAP001970	WRM775823
200.0	215.2	10.1	207.0	WAP002000	WRM787847
210.0	224.2	7.1	217.0	WAP002100	WRM826883
210.0	225.0	7.0	217.0	WAP102100	WRM826885
219.5	233.7	7.1	226.5	WAP002195	WRM860919
223.0	235.0	6.3	228.0	WAP002230	WRM878925
244.5	258.7	7.1	251.5	WAP002445	WRM9621017
249.0	261.0	6.3	254.0	WAP002490	WRM9801027
260.0	275.2	10.1	268.0	WAP002600	WRM10241078

* Available upon request

! This page is intentionally left blank.