

# Scrapers

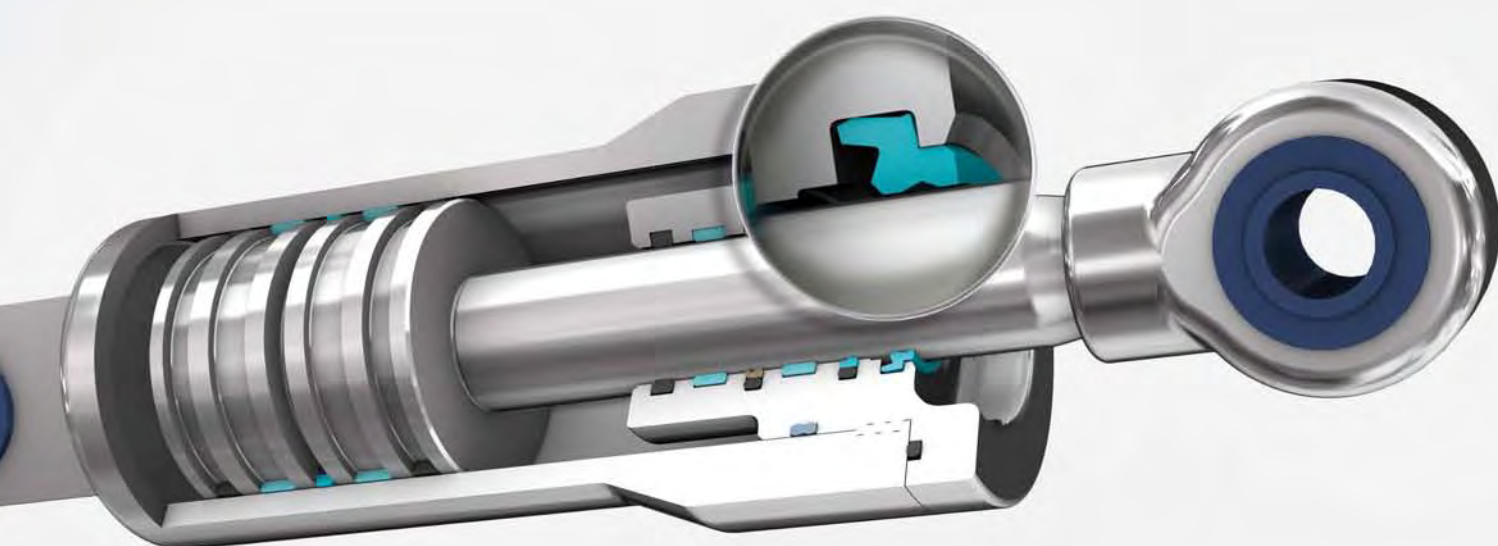



## Contents

<b>478</b>	<b>Choice of Scraper Element</b>	<b>577</b>	<b>Zurcon® Scraper WNV</b>
<b>483</b>	<b>Turcon® Excluder® 2</b>	<b>581</b>	<b>Scraper WSA</b>
<b>491</b>	<b>Turcon® Excluder® 5</b>	<b>587</b>	<b>Zurcon® Scraper SWP</b>
<b>499</b>	<b>Turcon® Excluder® Z</b>	<b>593</b>	<b>Metal Scraper</b>
<b>507</b>	<b>Turcon® Excluder® F</b>	<b>599</b>	<b>Turcon® Variseal® M2S</b>
<b>517</b>	<b>Turcon® Excluder® S</b>	<b>607</b>	<b>Additional Scrapers</b>
<b>529</b>	<b>Turcon® Excluder® 1 and 113</b>		
<b>539</b>	<b>Scraper DA17</b>		
<b>545</b>	<b>Zurcon® Scraper DA22</b>		
<b>551</b>	<b>Zurcon® Scraper DA24 &amp; DA24 Venting version</b>		
<b>557</b>	<b>Scraper WRM</b>		
<b>565</b>	<b>Zurcon® Scraper ASW</b>		
<b>571</b>	<b>Zurcon® Scraper WNE</b>		

## ■ Choice of Scraper Element

Scrapers are installed in hydraulic cylinders to wipe any dirt, foreign particles, chips, moisture, etc. from the piston rods as they are retracted into the system, thus preventing contamination of the hydraulic medium which would otherwise damage wear rings, seals and other components.

Single and double-acting scrapers can be used, depending on the application and the sealing system. They differ quite distinctly in their function: single-acting scrapers are designed to keep out contamination from the outside; double-acting scrapers have the additional function of optimising the sealing system and scraping off the existing residual fluid film, to avoid any external leakage.

In order to satisfy both the different technical and economic demands, there is a complete range of scrapers with optimised geometries made with high-quality materials.

Before selecting the scraper and the material, it is essential to know all the desired functional parameters. The table on following pages allows a preliminary choice of the scraper type and material, according to the specific requirements of the application.

Further general informations together with specific design and installation instructions for the particular scraper type and material can be found.

### NOTE ON ORDERING







All multi-element standard scrapers are generally supplied as a complete set. The set includes scraper and energizing element. The O-Ring does not have to be ordered separately. It is also possible, however, to use other O-Ring materials from our O-Ring Catalogue. In this case, please order the scraper and O-Ring separately.

Older designs of scrapers no longer contained in this catalogue obviously continue to be available. When possible, however, for new applications we recommend the use of DIN/ISO series listed in the catalogue.

The sizes contained in this catalogue are generally available from stock and can be supplied at short notice. We reserve the right to modify our article structure without prior notice.

Please do not hesitate to contact your local Trelleborg Sealing Solutions marketing company for further information on specific applications and special technical questions.







Table 160: Selection Criteria for Scrapers

Scraper		Application			Standard	Groove Type	Action		Size Range	Technical Data*		Recommended Scraper Material
Type	Page	Field of Application					ISO	mm		Single	Double	
			Light	Medium	Heavy					°C	m/s	
Turcon® Excluder® 2 	483	Industrial hydraulics	•	•	•	6195 Type D	Split < 30 Closed > 30	•	4 - 2,600	-45/+200	15	M12
		Machine tools	•	•	•							T46
Turcon® Excluder® 5 	491	Heavy duty mobile and industrial hydraulics	•	•	•	6195 Type D	Split < 30 Closed > 30	•	20 - 2,600	-45/+200	15	M12
		Presses	•	•	•				T46			
		Steel mills	•	•	•				20 - 2,200	-45/+110	2	Z54
Turcon® Excluder® Z 	499	Medium/Heavy duty mobile and industrial hydraulics	•	•	•	6195 Type D	Split < 25 Closed > 25	•	22 - 125	-45/+110	1	Z13
Turcon® Excluder® F 	507	Machine tools	•	•		-	Closed > 19	•	19 - 1,500	-45/+200	15	M12
		Automation	•	•								T46
Turcon® Excluder® S 	517	Heavy hydraulics		•	•	-	Split	•	16 - 2,600	-45/+200	15	M12
		Offshore hydraulics		•	•							
		Water barriers		•	•							
Turcon® Excluder® 1 and 113 	529	Industrial hydraulics	•	•		6195 Type D	Split < 30 Closed > 30	•	6 - 999.9	-45/+200	15	M12
		Machine tools	•	•						T46		
		Servo hydraulics	•	•								

\* The data above are maximum values and cannot be used at the same time.





\*\* Temperature Range depends on choice of elastomer material and media.

Table continues on next page

Scraper		Application			Standard	Groove Type	Action		Size Range	Technical Data*		Recommended Scraper Material
Type	Page	Field of Application					ISO	mm		Single	Double	
			Light	Medium	Heavy					°C	m/s	
Scraper DA17 	539	Industrial hydraulics Machine tools Presses	• • •	• • •		-	Split < 18 Closed > 18	•	10 - 440	-30/+110	1	NBR
Zurcon® Scraper DA22 	545	ISO standard cylinder Industrial hydraulic cylinders	• •	• •	•	6195 Type C	Split < 18 Closed > 18	•	5 - 180	-35/+100	1	Z201
Zurcon® Scraper DA24 & DA24 Venting Version 	551	Mobile hydraulics Construction machinery Agriculture machinery	• • •	• • •	•	-	Closed	•	45 - 290	-35/+100	1	Z201
Scraper WRM 	557	Agriculture machinery Handling equipment	• •	• •		-	Closed	•	12 - 260	-30/+110	1	NBR
Zurcon® Scraper ASW 	565	Agriculture machinery Mobile hydraulic machinery	• •	• •		-	Split < 14 Closed > 14	•	8 - 125	-35/+100	1	Z201
Zurcon® Scraper WNE 	571	Agriculture machinery Mobile hydraulic machinery	• •	• •	•	-	Closed	•	8 - 250	-35/+100	1	Z201

\* The data above are maximum values and cannot be used at the same time.

\*\* Temperature Range depends on choice of elastomer material and media.

Scraper		Application				Standard	Groove Type	Action		Size Range	Technical Data*		Recommended Scraper Material
											Temp. Range**	Speed	
Type	Page	Field of Application			ISO	mm	Single	Double	mm	°C	m/s		
			Light	Medium									Heavy
Zurcon® Scraper WNV 	577	Agriculture machinery	•	•	•	6195 Type A	Closed	•	16 - 100	-35/+100	1	Z201	
		Mobile hydraulic machinery	•	•	•								
		ISO standard cylinder	•	•	•								
		Lift trucks	•	•	•								
		Cargo tailboards Steering cylinders	•	•	•								
Scraper WSA 	581	Agriculture machinery	•	•		-	Open	•	16 - 120	-30/+110	1	NBR + Metal	
		Standard hydraulic cylinder	•	•									
Zurcon® Scraper SWP 	587	Construction machinery		•	•	-	Open	•	25 - 190	-35/+100	1	Z201 + Metal	
		Link pin seals		•	•								
Metal Scraper 	593	Agriculture machinery	•	•	•	-	Open	•	12 - 220	-30/+110	1	Metal + NBR + Brass	
		Mobile hydraulic machinery	•	•	•								
		ISO standard cylinder	•	•	•								
Turcon® Variseal® M2S 	599	Marine environments	•	•	•	-	Split or Stepped Housing	•	3 - 3,200	-50/+80	2	Z80	
		Subsea Application	•	•	•	-				-50/+260	15	T40	
		Hydraulics	•	•	•	-				-196/+80	1	Z80	
		Low temperature / Cryogenic	•	•		-				-50/+260	15	T40	
		Chemical processing	•	•	•	-				-50/+80	2	Z81	
		Food & Pharmaceutical	•	•		-				-50/+260	15	MF4	

\* The data above are maximum values and cannot be used at the same time.

\*\* Temperature Range depends on choice of elastomer material and media.

---

! This page is intentionally left blank.



# Turcon® Excluder® 2



---

Double-acting

---

Rubber-energized Double-acting scraper

**Material:**

Turcon®, Zurcon® and Elastomer

---







## Turcon® Excluder® 2



### Description

Turcon® Excluder® 2 is a patented double-acting scraper with scraper lip and sealing lip, positioned back-to-back. Excluder® 2 is always installed with an elastic O-Ring in one groove. The scraper function is performed by Excluder® 2. The O-Ring maintains the pressure of the scraper lips against the sliding surface and can compensate any deflections of the piston rod.

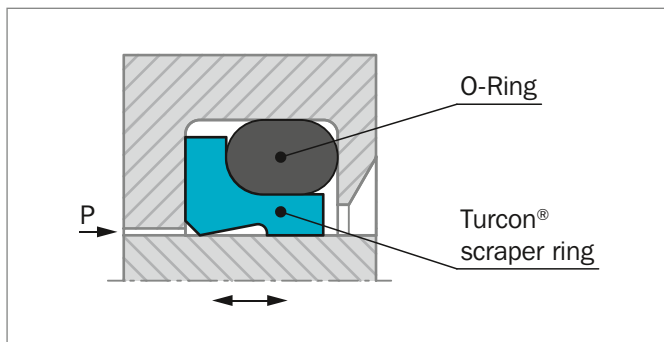

Figure 173: Turcon® Excluder® 2

Excluder® 2 has two functions:

- Scrape contaminants from the retracting piston rod to protect the system from soiling
- Hold back the residual oil film on the extending piston rod on the medium side.

Excluder® 2 is used in conjunction with our rod seals Turcon® Stepseal® 2K, Turcon® VL Seal® or Zurcon® Rimseal, i.e. seals with hydrodynamic back-pumping function.

### ADVANTAGES

- Outstanding sliding properties
- Stick-slip-free, no sticking
- Can compensate for deflections of the piston rod
- Space-saving construction
- Very good scraping effect against outside contaminants, even with firmly adhered dirt, etc.
- Very good scraping effect from the inside against the residual oil film adhering to the surface of the piston rod
- Very high resistance to hydraulic media
- Available for all diameters up to 2,600 mm (Turcon®) and up to 2,200 mm (Zurcon® Z53/Z54)
- ISO 6195 Type D installation dimensions up to diameter 63 mm

### OPERATING CONDITIONS

<b>Speed:</b>	Up to 15 m/s for Turcon® materials
	Up to 2 m/s for Zurcon® materials
<b>Temperature:</b>	-45 °C to +200 °C (Turcon®)
	-45 °C to +110 °C (Zurcon® Z53/Z54)
	-60 °C to +80 °C (Zurcon® Z80)
	(depending on O-Ring materials)
<b>Media:</b>	Mineral oil-based hydraulic fluids, flame retardant hydraulic fluids, environmentally friendly hydraulic fluids (bio-oils), phosphate ester, water, air and others, depending on the O-Ring material compatibility.

### IMPORTANT NOTE

The above data are maximum values and cannot be used at the same time, e.g. the maximum operating speed depends on material type, pressure, temperature and gap value. Temperature range also depends on media.

### INSTALLATION INSTRUCTIONS

Excluder® 2 scrapers can be installed in split and closed grooves (installation dimensions, see Table 161. Installation in closed grooves depends on the rod diameter, profile cross-section of the scraper and on the cord cross-section of the corresponding O-Ring, see Table 163.

**Table 161: Installation in Closed Grooves**

Turcon® Excluder® 2 Series No.	Rod Diameter $d_N$	O-Ring Cross-Section $d_2$
WE30	> 30	1.78
WE31	> 30	2.62
WE32	> 40	3.53
WE33	> 50	5.33
WE34	> 110	7.00
WE35	> 140	8.40



### RECOMMENDED MATERIALS

The following material combinations have proven effective for hydraulic applications:

#### Turcon® Excluder® 2 in Turcon® M12

All round material for light to medium hydraulic applications with linear, short stroke or helical movements in mineral oils, flame retardant hydraulic fluids, phosphate ester, bio-oils or fluids having low lubricating properties:

O-Ring:                   NBR 70 Shore A       N  
                                  FKM 70 Shore A       V

Set code:                   M12N or M12V

#### Turcon® Excluder® 2 in Turcon® T46

For medium to heavy applications with linear movements in mineral oils and other media with good lubrication:

O-Ring:                   NBR 70 Shore A       N  
                                  FKM 70 Shore A       V

Set code:                   T46N or T46V

For specific applications, all Turcon® materials are available.

Other material combinations are listed in Table 162.

**Table 162: Turcon® and Zurcon® Materials for Excluder® 2**

Material, Applications, Properties	Code	O-Ring Material Shore A	Code	O-Ring Operating Temp. * °C	Mating Surface Material	Speed max. m/s
<b>Turcon® M12</b> First material choice for linear motion Overall improved properties For new constructions and updating For all commonly applied hydraulic fluids including fluids with low lubrication performance Lowest friction and best sliding properties Lowest wear on scrapers Improved absorption of abrasive contaminants Low wear or abrasion of counter surface BAM tested Mineral fiber and Additives filled Color: Dark gray	M12	NBR 70	N	-30 to +100	Steel	15
		NBR 70 Low temp.	T	-45 to +80	Steel, hardened Steel, chrome plated (rod)	
		FKM 70	V	-10 to +200	Steel plated Cast iron Stainless steel Titanium	
<b>Turcon® T40</b> For lubricating and non-lubricating fluids High frequency and short strokes Water hydraulics Surface texture is not suitable for gas sealing Carbon fiber filled Color: Gray	T40	NBR 70	N	-30 to +100	Steel	15
		NBR 70 Low temp.	T	-45 to +80	Steel, chrome plated (rod) Cast iron	
		FKM 70	V	-10 to +200	Stainless steel	
		EPDM 70	E**	-45 to +145	Aluminum	

Table continues on next page



Material, Applications, Properties	Code	O-Ring Material Shore A	Code	O-Ring Operating Temp. * °C	Mating Surface Material	Speed max. m/s
<b>Turcon® T46</b> For lubricated hydraulics in linear motion High compressive strength High extrusion resistance Very good sliding and wear properties BAM tested Bronze filled Color: Light to dark brown, which may have variations in shading.	T46	NBR 70	N	-30 to +100	Steel, hardened	15
		NBR 70 Low temp.	T	-45 to +80	Steel, chrome plated (rod) Cast iron	
		FKM 70	V	-10 to +200		
<b>Zurcon® Z53***</b> For mineral oil based fluids Very high abrasion and extrusion resistance For counter surface with rougher surface finish More difficult to install Limited chemical resistance Max. working temperature +110 °C Cast polyurethane Color: Yellow to light-brown	Z53	NBR 70	N	-30 to +100	Steel	2
		NBR 70 Low temp.	T	-45 to +80	Steel, hardened Steel chrome plated (rod) Cast iron Ceramic coating Stainless steel	
<b>Zurcon® Z54***</b> For mineral oil based fluids Linear and slowly turning movements High abrasion resistance For counter surface with rougher surface finish Good extrusion resistance Limited chemical resistance Max. working temperature +110 °C Cast polyurethane Color: Turquoise	Z54	NBR 70	N	-30 to +100	Steel	2
		NBR 70 Low temp.	T	-45 to +80	Steel, hardened Steel, chrome plated (rod) Cast iron Stainless steel Aluminum Ceramic coating	
<b>Zurcon® Z80</b> For lubricating and non-lubricating fluids Water based fluids, air and gases Dry air pneumatics High abrasion and extrusion resistance For service in abrasive conditions and media with particles Good chemical resistance Limited temperature capability (-60 to +80 °C) UHMWPE (Ultra High Molecular Weight Polyethylene)	Z80	NBR 70	N	-30 to (+100)	Steel	2
		NBR 70 Low temp.	T	-45 to +80	Steel, chrome plated (rod) Stainless steel Aluminum Ceramic coating	
		EPDM 70	E**	-45 to (+145)		

\* The O-Ring operating temperatures are only valid in mineral hydraulic oil (except EPDM).

\*\* Material not suitable for mineral oils.

\*\*\* Max. diameter 2,200 mm

BAM: Tested by "Bundesanstalt Materialprüfung, Germany".

Highlighted materials are recommended.



## Installation Recommendation

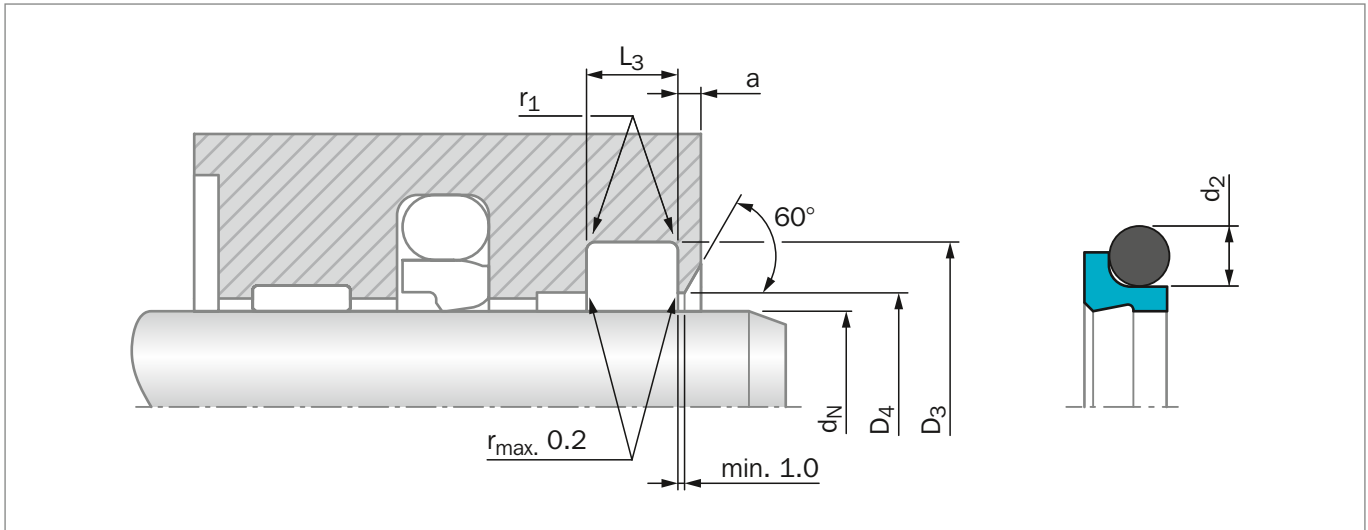

Figure 174: Installation Drawing

**Table 163: Installation Dimension - Standard Recommendations**

Series No.	Rod Diameter $d_N$ f8/h9		Groove Diameter $D_3$ H9	Groove Width $L_3$ +0.2/-0.0	Bore Diameter $D_4$ H11	Step Width $a_{min.}$	Radius $r_1$ max	O-Ring Cross Section $d_2$
	Standard Application	Available Range						
WE30	4 – 11.9	4 – 130	$d_N + 4.8$	3.7	$d_N + 1.5$	2.0	0.4	1.78
WE31	12 – 64.9	10 – 245	$d_N + 6.8$	5.0	$d_N + 1.5$	2.0	0.8	2.62
WE32	65 – 250.9	25 – 400	$d_N + 8.8$	6.0	$d_N + 1.5$	3.0	1.0	3.53
WE33	251 – 420.9	40 – 655	$d_N + 12.2$	8.4	$d_N + 2.0$	4.0	1.5	5.33
WE34	421 – 650.9	110 – 655	$d_N + 16.0$	11.0	$d_N + 2.0$	4.0	1.5	7.00
WE35	651 – 999.9	140 – 999.9	$d_N + 20.0$	14.0	$d_N + 2.5$	5.0	2.0	8.40
WE35X	1,000 - 2,600		$d_N + 20.0$	14.0	$d_N + 2.5$	5.0	2.0	8.40

For diameters  $d_N > 400$  mm we recommend the use of Turcon® Excluder® 5.

### ORDERING EXAMPLE

Turcon® Excluder® 2 complete with O-Ring, standard application:

<b>Series:</b>	WE31 from Table 163
<b>Rod Diameter:</b>	$d_N = 50.0$ mm
<b>TSS Part No.:</b>	WE3100500 from Table 164

Select the material from Table 162. The corresponding code numbers are appended to the TSS Part No. Together these form the TSS Article Number. The TSS Article Number for all intermediate sizes can be determined by following the example:

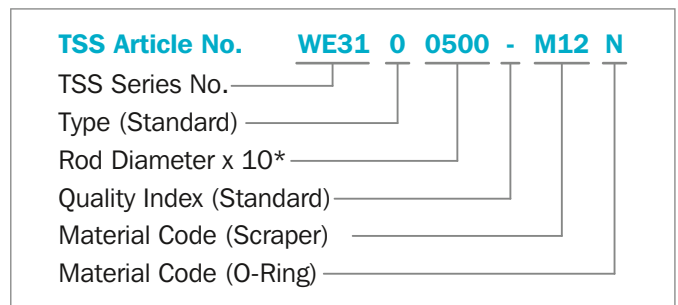

\* For diameters  $d_N \geq 1,000.0$  mm multiply only by factor 1.  
 Example: WE35 for diameter  $d_N = 1,200.0$  mm  
 TSS Article No.: WE35X1200-M12N



Table 164: Installation Dimensions / TSS Part Numbers

Rod Dia.	Groove Dia.	Groove Width	TSS Part No.	O-Ring Size	Rod Dia.	Groove Dia.	Groove Width	TSS Part No.	O-Ring Size
$d_N$ f8/h9	$D_3$ H9	$L_3$ +0.2			$d_N$ f8/h9	$D_3$ H9	$L_3$ +0.2		
<b>4.0*</b>	<b>8.8</b>	<b>3.7</b>	<b>WE3000040</b>	<b>5.60 x 1.80</b>	55.0	61.8	5.0	WE3100550	56.82 x 2.62
<b>5.0*</b>	<b>9.8</b>	<b>3.7</b>	<b>WE3000050</b>	<b>6.70 x 1.80</b>	<b>56.0*</b>	<b>62.8</b>	<b>5.0</b>	<b>WE3100560</b>	<b>58.42 x 2.62</b>
<b>6.0*</b>	<b>10.8</b>	<b>3.7</b>	<b>WE3000060</b>	<b>7.65 x 1.78</b>	58.0	64.8	5.0	WE3100580	59.99 x 2.62
<b>8.0*</b>	<b>12.8</b>	<b>3.7</b>	<b>WE3000080</b>	<b>9.50 x 1.80</b>	60.0	66.8	5.0	WE3100600	61.60 x 2.62
<b>10.0*</b>	<b>14.8</b>	<b>3.7</b>	<b>WE3000100</b>	<b>11.8 x 1.80</b>	<b>63.0*</b>	<b>69.8</b>	<b>5.0</b>	<b>WE3100630</b>	<b>64.77 x 2.62</b>
<b>12.0*</b>	<b>18.8</b>	<b>5.0</b>	<b>WE3100120</b>	<b>13.94 x 2.62</b>	65.0	73.8	6.0	WE3200650	66.27 x 3.53
<b>14.0*</b>	<b>20.8</b>	<b>5.0</b>	<b>WE3100140</b>	<b>15.54 x 2.62</b>	<b>70.0</b>	<b>78.8</b>	<b>6.0</b>	<b>WE3200700</b>	<b>72.62 x 3.53</b>
15.0	21.8	5.0	WE3100150	17.12 x 2.62	73.0	81.8	6.0	WE3200730	75.79 x 3.53
<b>16.0</b>	<b>20.8</b>	<b>3.7</b>	<b>WE3000160</b>	<b>17.17 x 1.78</b>	75.0	83.8	6.0	WE3200750	75.79 x 3.53
<b>16.0*</b>	<b>22.8</b>	<b>5.0</b>	<b>WE3100160</b>	<b>18.00 x 2.65</b>	<b>80.0</b>	<b>88.8</b>	<b>6.0</b>	<b>WE3200800</b>	<b>82.14 x 3.53</b>
17.8	24.6	5.0	WE3100178	20.29 x 2.65	81.0	89.8	6.0	WE3200810	82.14 x 3.53
<b>18.0</b>	<b>22.8</b>	<b>3.7</b>	<b>WE3000180</b>	<b>19.00 x 1.80</b>	85.0	93.8	6.0	WE3200850	85.32 x 3.53
<b>18.0*</b>	<b>24.8</b>	<b>5.0</b>	<b>WE3100180</b>	<b>20.29 x 2.62</b>	86.0	94.8	6.0	WE3200860	88.49 x 3.53
<b>20.0</b>	<b>24.8</b>	<b>3.7</b>	<b>WE3000200</b>	<b>21.95 x 1.78</b>	88.0	96.8	6.0	WE3200880	88.49 x 3.53
<b>20.0*</b>	<b>26.8</b>	<b>5.0</b>	<b>WE3100200</b>	<b>21.89 x 2.62</b>	<b>90.0</b>	<b>98.8</b>	<b>6.0</b>	<b>WE3200900</b>	<b>91.67 x 3.53</b>
<b>22.0</b>	<b>26.8</b>	<b>3.7</b>	<b>WE3000220</b>	<b>23.52 x 1.78</b>	95.0	103.8	6.0	WE3200950	98.02 x 3.53
<b>22.0*</b>	<b>28.8</b>	<b>5.0</b>	<b>WE3100220</b>	<b>23.47 x 2.62</b>	<b>100.0</b>	<b>108.8</b>	<b>6.0</b>	<b>WE3201000</b>	<b>101.19 x 3.53</b>
24.0	30.8	5.0	WE3100240	26.64 x 2.62	105.0	113.8	6.0	WE3201050	107.54 x 3.53
<b>25.0*</b>	<b>31.8</b>	<b>5.0</b>	<b>WE3100250</b>	<b>26.64 x 2.62</b>	<b>110.0</b>	<b>118.8</b>	<b>6.0</b>	<b>WE3201100</b>	<b>110.72 x 3.53</b>
<b>28.0*</b>	<b>34.8</b>	<b>5.0</b>	<b>WE3100280</b>	<b>29.82 x 2.62</b>	115.0	123.8	6.0	WE3201150	117.07 x 3.53
29.8	36.6	5.0	WE3100298	31.42 x 2.62	120.0	128.8	6.0	WE3201200	120.24 x 3.53
30.0	34.8	3.7	WE3000300	31.47 x 1.78	<b>125.0</b>	<b>133.8</b>	<b>6.0</b>	<b>WE3201250</b>	<b>126.59 x 3.53</b>
30.0	36.8	5.0	WE3100300	31.42 x 2.62	130.0	138.8	6.0	WE3201300	132.94 x 3.53
<b>32.0*</b>	<b>38.8</b>	<b>5.0</b>	<b>WE3100320</b>	<b>34.59 x 2.62</b>	135.0	143.8	6.0	WE3201350	136.12 x 3.53
33.0	37.8	3.7	WE3000330	34.65 x 1.78	137.0	145.8	6.0	WE3201370	139.29 x 3.53
34.8	41.6	5.0	WE3100348	36.17 x 2.62	<b>140.0</b>	<b>148.8</b>	<b>6.0</b>	<b>WE3201400</b>	<b>142.47 x 3.53</b>
35.0	39.8	3.7	WE3000350	34.65 x 1.78	145.0	153.8	6.0	WE3201450	145.64 x 3.53
35.0	41.8	5.0	WE3100350	36.17 x 2.62	150.0	158.8	6.0	WE3201500	151.99 x 3.53
<b>36.0*</b>	<b>42.8</b>	<b>5.0</b>	<b>WE3100360</b>	<b>37.77 x 2.62</b>	150.0	162.2	8.4	WE3301500	151.77 x 5.33
37.0	43.8	5.0	WE3100370	39.34 x 2.62	<b>160.0</b>	<b>168.8</b>	<b>6.0</b>	<b>WE3201600</b>	<b>158.34 x 3.53</b>
<b>40.0*</b>	<b>46.8</b>	<b>5.0</b>	<b>WE3100400</b>	<b>42.52 x 2.62</b>	170.0	178.8	6.0	WE3201700	171.04 x 3.53
42.0	48.8	5.0	WE3100420	44.12 x 2.62	<b>180.0</b>	<b>188.8</b>	<b>6.0</b>	<b>WE3201800</b>	<b>177.39 x 3.53</b>
42.8	49.6	5.0	WE3100428	44.12 x 2.62	190.0	198.8	6.0	WE3201900	190.09 x 3.53
44.0	48.8	3.7	WE3000440	44.17 x 1.78	<b>200.0</b>	<b>208.8</b>	<b>6.0</b>	<b>WE3202000</b>	<b>202.79 x 3.53</b>
<b>45.0*</b>	<b>49.8</b>	<b>3.7</b>	<b>WE3000450</b>	<b>47.35 x 1.78</b>	210.0	218.8	6.0	WE3202100	209.14 x 3.53
45.0	51.8	5.0	WE3100450	47.29 x 2.62	<b>220.0</b>	<b>228.8</b>	<b>6.0</b>	<b>WE3202200</b>	<b>221.84 x 3.53</b>
49.0	55.8	5.0	WE3100490	50.47 x 2.62	230.0	238.8	6.0	WE3202300	228.19 x 3.53
<b>50.0*</b>	<b>56.8</b>	<b>5.0</b>	<b>WE3100500</b>	<b>52.07 x 2.62</b>	240.0	248.8	6.0	WE3202400	240.89 x 3.53
<b>50.0</b>	<b>62.2</b>	<b>8.4</b>	<b>WE3300500</b>	<b>53.34 x 5.33</b>	<b>250.0</b>	<b>258.8</b>	<b>6.0</b>	<b>WE3202500</b>	<b>253.59 x 3.53</b>
54.0	60.8	5.0	WE3100540	55.25 x 2.62	260.0	272.2	8.4	WE3302600	253.37 x 5.33



Rod Dia.	Groove Dia.	Groove Width	TSS Part No.	O-Ring Size
$d_N$ f8/h9	$D_3$ H9	$L_3$ +0.2		
<b>280.0</b>	<b>292.2</b>	<b>8.4</b>	<b>WE3302800</b>	<b>278.77 x 5.33</b>
300.0	312.2	8.4	WE3303000	304.17 x 5.33
<b>320.0</b>	<b>332.2</b>	<b>8.4</b>	<b>WE3303200</b>	<b>329.57 x 5.33</b>
350.0	362.2	8.4	WE3303500	354.97 x 5.33
<b>360.0</b>	<b>372.2</b>	<b>8.4</b>	<b>WE3303600</b>	<b>354.97 x 5.33</b>
370.0	382.2	8.4	WE3303700	365.00 x 5.30
400.0	412.2	8.4	WE3304000	405.26 x 5.33
500.0	516.0	11.0	WE3405000	494.16 x 7.00
600.0	616.0	11.0	WE3406000	608.08 x 7.00
700.0	720.0	14.0	WE3507000	705 x 8.40
800.0	820.0	14.0	WE3508000	805 x 8.40
900.0	920.0	14.0	WE3509000	905 x 8.40
1,200.0	1,220.0	14.0	WE35X1200	1,205 x 8.40
1,800.0	1,820.0	14.0	WE35X1800	1,805 x 8.40
2,600.0	2,620.0	14.0	WE35X2600	2,605 x 8.40

The rod diameters in **bold** type comply with the recommendations of ISO 3,320.

\* Installation in grooves according to ISO 6,195 Type D



# Turcon® Excluder® 5



---

Double-acting

---

Rubber-energized Double-acting Scraper

**Material:**

Turcon®, Zurcon® and Elastomer

---







## Turcon® Excluder® 5\*



### Description

Turcon® Excluder® 5 is a patented double-acting scraper with scraper lip and sealing lip, positioned back-to-back. The scraper is installed with an O-Ring as elastic energizing element in one groove. The scraper function is performed by the Excluder® 5 Turcon® element. The O-Ring maintains the pressure of the scraper lips against the sliding surface and can compensate deflections of the piston rod.

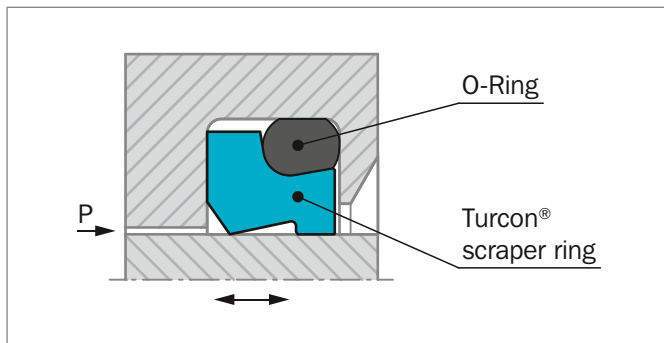

Figure 175: Turcon® Excluder® 5

Excluder® 5 has two functions:

- Scrape contaminants from the retracting piston rod to protect the system from soiling
- Hold back the residual oil film on the extending piston rod on the medium side.

Excluder® 5 is used in conjunction with our rod seals Turcon® Stepseal® 2K, Turcon® VL Seal® or Zurcon® Rimseal, i.e. seals with a hydrodynamic back-pumping function. In contrast to Excluder® 2, they are used particularly for heavy-duty applications such as in construction machinery, presses, etc.

### ADVANTAGES

- Outstanding sliding properties
- Stick-slip-free, no sticking (Turcon® material)
- Tough scraper for heavy-duty operation
- Can compensate for deflections of the piston rod or plunger
- Very good scraping effect even against firmly adhered dirt, etc.
- Very good scraping effect from the inside against the residual oil film adhering to the surface of the piston rod
- Identical installation with that of the Zurcon® Excluder® 500
- Very high resistance to hydraulic media

- Available for all diameters up to 2,600 mm (Turcon®), up to 2,200 mm (Zurcon® Z53/Z54).
- ISO 6195 Type D installation dimensions from diameter 40 mm

### OPERATING CONDITIONS

<b>Speed:</b>	Up to 15 m/s for Turcon® materials Up to 2 m/s for Zurcon® materials
<b>Temperature:</b>	-45 °C to +200 °C (Turcon®) -45 °C to +110 °C (Zurcon® Z53/Z54) -60 °C to +80 °C (Zurcon® Z80) depending on O-Ring material
<b>Media:</b>	Mineral oil-based hydraulic fluids, flame retardant hydraulic fluids, environmentally friendly hydraulic fluids (bio-oils), phosphate ester, water, air and others, depending on the scraper and O-Ring material compatibility.

### IMPORTANT NOTE

The above data are maximum values and cannot be used at the same time, e.g. the maximum operating speed depends on material type, pressure, temperature and gap value. Temperature range also depends on media.

### INSTALLATION INSTRUCTIONS

Excluder® 5 scrapers can be installed in split and closed grooves installation dimensions, see Table 165.

Installation in closed grooves depends on the rod diameter, profile cross-section of the scraper and on the cross section of the corresponding O-Ring, see Table 167.

**Table 165: Installation in Closed Grooves**

Turcon® Excluder® 5 Series No.	Rod Diameter $d_N$	O-Ring Cross Section $d_2$
WE50	> 30.0	2.62
WE51	> 40.0	2.62
WE52	> 70.0	3.53
WE53	> 100.0	5.33
WE54	> 140.0	7.00
WE55	> 180.0	8.40

\* Patent-No. EP 023 5568



**RECOMMENDED MATERIALS**

The following material combinations have proven effective for most applications:

**Turcon® Excluder® 5 in Turcon® M12**

All round material for light to heavy hydraulic applications with linear, short stroke or helical movements in mineral oils, flame retardant hydraulic fluids, phosphate ester, bio-oils or fluids having low lubricating properties:

O-Ring:       NBR 70 Shore A     N  
                  FKM 70 Shore A     V

Set code:     M12N or M12V

**Turcon® Excluder® 5 in Turcon® T46**

For medium to heavy applications with linear movements in mineral oils and other media with good lubrication:

O-Ring:       NBR 70 Shore A     N  
                  FKM 70 Shore A     V

Set code:     T46N or T46V

For specific applications, all Turcon® materials are available.

Other material combinations are listed in Table 166.

**Table 166: Turcon® and Zurcon® Materials for Excluder® 5**

Material, Applications, Properties	Code	O-Ring Material Shore A	Code	O-Ring Operating Temp. * °C	Mating Surface Material	Speed max. m/s
<b>Turcon® M12</b> First material choice for linear motion Overall improved properties For new constructions and updating For all commonly applied hydraulic fluids including fluids with low lubrication performance Lowest friction and best sliding properties Lowest wear on scrapers Improved absorption of abrasive contaminants Low wear or abrasion of counter surface BAM tested Mineral fiber and Additives filled Color: Dark gray	M12	NBR 70	N	-30 to +100	Steel Steel, hardened Steel, chrome plated (rod) Cast iron Stainless steel Titanium	15
		NBR 70 Low temp.	T	-45 to +80		
		FKM 70	V	-10 to +200		
<b>Turcon® T40</b> For lubricating and non-lubricating fluids High frequency and short strokes Water hydraulics Surface texture is not suitable for gas sealing Carbon fiber filled Color: Gray	T40	NBR 70	N	-30 to +100	Steel Steel, chrome plated (rod) Cast iron Stainless steel Aluminum	15
		NBR 70 Low temp.	T	-45 to +80		
		FKM 70	V	-10 to +200		
		EPDM 70	E**	-45 to +145		

Table continues on next page



Material, Applications, Properties	Code	O-Ring Material Shore A	Code	O-Ring Operating Temp. * °C	Mating Surface Material	Speed max. m/s
<b>Turcon® T46</b> For lubricated hydraulics in linear motion High compressive strength High extrusion resistance Very good sliding and wear properties BAM tested Bronze filled Color: Light to dark brown, which may have variations in shading.	T46	NBR 70	N	-30 to +100	Steel, hardened	15
		NBR 70 Low temp.	T	-45 to +80	Steel, chrome plated (rod) Cast iron	
		FKM 70	V	-10 to +200		
<b>Zurcon® Z53***</b> For mineral oil based fluids Linear and slowly turning movements Very high abrasion and extrusion resistance For counter surface with rougher surface finish More difficult to install Limited chemical resistance Max. working temperature 110 °C Cast polyurethane Color: Yellow to light-brown	Z53	NBR 70	N	-30 to +100	Steel	2
		NBR 70 Low temp.	T	-45 to +80	Steel, hardened Steel chrome plated (rod) Cast iron Ceramic coating Stainless steel	
<b>Zurcon® Z54***</b> For mineral oil based fluids High abrasion resistance For counter surface with rougher surface finish Good extrusion resistance Limited chemical resistance Max. working temperature 110 °C Cast polyurethane Color: Turquoise	Z54	NBR 70	N	-30 to +100	Steel	1
		NBR 70 Low temp.	T	-45 to +80	Steel, hardened Steel, chrome plated (rod) Cast iron Stainless steel Aluminum Ceramic coating	
<b>Zurcon® Z80</b> For lubricating and non-lubricating fluids Water based fluids, air and gases Dry air pneumatics High abrasion and extrusion resistance For service in abrasive conditions and media with particles Good chemical resistance Limited temperature capability (-60 to +80 °C) UHMWPE (Ultra High Molecular Weight Polyethylene)	Z80	NBR 70	N	-30 to (+100)	Steel	2
		NBR 70 Low temp.	T	-45 to +80	Steel, chrome plated (rod) Stainless steel	
		EPDM 70	E**	-45 to (+145)	Aluminum Ceramic coating	

\* The O-Ring Operation Temperature is only valid in mineral hydraulic oil (except EPDM).

\*\* Material not suitable for mineral oils.

\*\*\* Max. diameter 2,200 mm

BAM: Tested by "Bundesanstalt Materialprüfung, Germany".

□ Highlighted materials are recommended.



## ■ Installation Recommendation

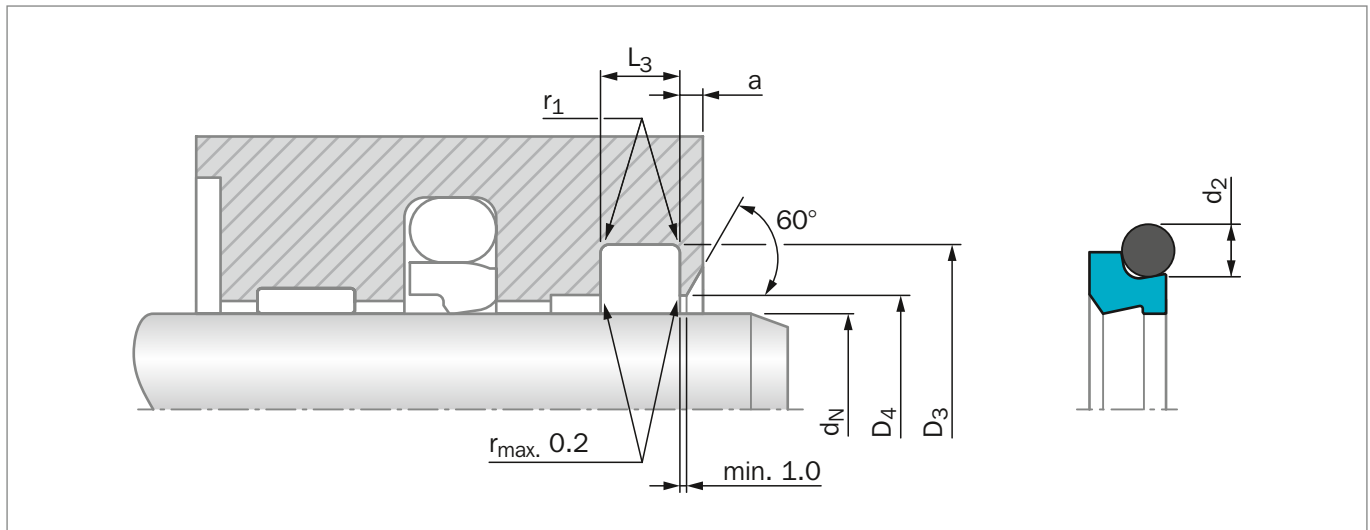

Figure 176: Installation Drawing

**Table 167: Installation Dimensions – Standard Recommendations**

Series No.	Rod Diameter $d_N$ f8/h9		Groove Diameter $D_3$ H9	Groove Width $L_3$ +0.2/-0.0	Bore Diameter $D_4$ H11	Step Width $a_{min}$	Radius $r_1$ max	O-Ring Cross Section $d_2$
	Standard Application	Available Range						
WE50	19 – 39.9	19 – 100.0	$d_N + 7.6$	4.2	$d_N + 1.5$	3.0	0.8	2.62
WE51	40 – 69.9	30 – 200.0	$d_N + 8.8$	6.3	$d_N + 1.5$	3.0	1.0	2.62
WE52	70 – 139.9	50 – 360.0	$d_N + 12.2$	8.1	$d_N + 2.0$	4.0	1.0	3.53
WE53	140 – 399.9	100 – 650.0	$d_N + 16.0$	9.5	$d_N + 2.5$	5.0	1.5	5.33
WE54	400 – 649.9	200 – 650.0	$d_N + 24.0$	14.0	$d_N + 2.5$	8.0	1.5	7.00
WE55	650 – 999.9	400 – 999.9	$d_N + 27.3$	16.0	$d_N + 2.5$	10.0	2.0	8.40
WE55X	1,000 - 2,600		$d_N + 27.3$	16.0	$d_N + 2.5$	10.0	2.0	8.40

### ORDERING EXAMPLE

Turcon® Excluder® 5 complete with O-Ring, standard application:

**Series:** WE51 from Table 167

**Rod Diameter:**  $d_N = 50.0$  mm

**TSS Part No.:** WE5100500 from Table 168

Select the material from Table 166. The corresponding code numbers are appended to the TSS Part No. Together these form the TSS Article Number. The TSS Article Number for all intermediate sizes can be determined by following the example:

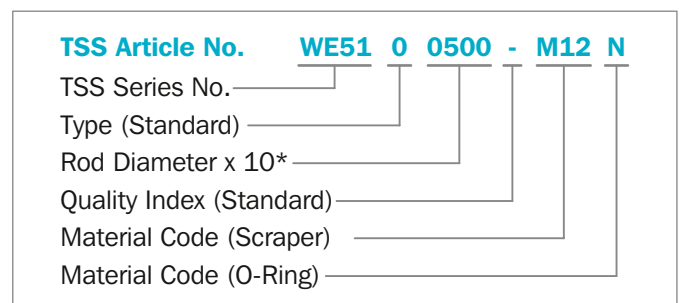

\* For diameters  $d_N \geq 1,000.0$  mm multiply only by factor 1.  
 Example: WE55 for diameter  $d_N = 1,200.0$  mm  
 TSS Article No.: WE55X1200-M12N



Table 168: Installation Dimensions / TSS Part No.

Rod Dia.	Groove Dia.	Groove Width	TSS Part No.	O-Ring Size	Rod Dia.	Groove Dia.	Groove Width	TSS Part No.	O-Ring Size
$d_N$ f8/h9	$D_3$ H9	$L_3$ +0.2			$d_N$ f8/h9	$D_3$ H9	$L_3$ +0.2		
19.0	26.6	4.2	<a href="#">WE5000190</a>	21.89 x 2.62	125.4	137.6	8.1	<a href="#">WE5201254</a>	129.77 x 3.53
<b>20.0</b>	<b>27.6</b>	<b>4.2</b>	<a href="#">WE5000200</a>	<b>21.89 x 2.62</b>	130.0	142.2	8.1	<a href="#">WE5201300</a>	136.12 x 3.53
<b>22.0</b>	<b>29.6</b>	<b>4.2</b>	<a href="#">WE5000220</a>	<b>25.07 x 2.62</b>	135.0	147.2	8.1	<a href="#">WE5201350</a>	139.29 x 3.53
<b>25.0</b>	<b>32.6</b>	<b>4.2</b>	<a href="#">WE5000250</a>	<b>28.24 x 2.62</b>	<b>140.0*</b>	<b>152.2</b>	<b>8.1</b>	<a href="#">WE5201400</a>	<b>145.64 x 3.53</b>
<b>28.0</b>	<b>35.6</b>	<b>4.2</b>	<a href="#">WE5000280</a>	<b>29.82 x 2.62</b>	<b>140.0*</b>	<b>156.0</b>	<b>9.5</b>	<a href="#">WE5301400</a>	<b>145.42 x 5.33</b>
30.0	37.6	4.2	<a href="#">WE5000300</a>	32.99 x 2.62	140.5	156.5	9.5	<a href="#">WE5301405</a>	145.42 x 5.33
<b>32.0</b>	<b>39.6</b>	<b>4.2</b>	<a href="#">WE5000320</a>	<b>34.59 x 2.62</b>	150.0	166.0	9.5	<a href="#">WE5301500</a>	151.77 x 5.33
35.0	42.6	4.2	<a href="#">WE5000350</a>	37.77 x 2.62	153.0	169.0	9.5	<a href="#">WE5301530</a>	158.12 x 5.33
<b>36.0</b>	<b>43.6</b>	<b>4.2</b>	<a href="#">WE5000360</a>	<b>37.77 x 2.62</b>	155.0	171.0	9.5	<a href="#">WE5301550</a>	158.12 x 5.33
<b>40.0*</b>	<b>48.8</b>	<b>6.3</b>	<a href="#">WE5100400</a>	<b>44.12 x 2.62</b>	<b>160.0*</b>	<b>172.2</b>	<b>8.1</b>	<a href="#">WE5201600</a>	<b>164.69 x 3.53</b>
42.0	50.8	6.3	<a href="#">WE5100420</a>	45.69 x 2.62	<b>160.0*</b>	<b>176.0</b>	<b>9.5</b>	<a href="#">WE5301600</a>	<b>164.47 x 5.33</b>
<b>45.0*</b>	<b>53.8</b>	<b>6.3</b>	<a href="#">WE5100450</a>	<b>48.90 x 2.62</b>	165.0	181.0	9.5	<a href="#">WE5301650</a>	170.82 x 5.33
48.0	56.8	6.3	<a href="#">WE5100480</a>	52.07 x 2.62	170.0	186.0	9.5	<a href="#">WE5301700</a>	177.17 x 5.33
<b>50.0*</b>	<b>58.8</b>	<b>6.3</b>	<a href="#">WE5100500</a>	<b>53.64 x 2.62</b>	175.0	191.0	9.5	<a href="#">WE5301750</a>	177.17 x 5.33
52.0	60.8	6.3	<a href="#">WE5100520</a>	55.25 x 2.62	<b>180.0*</b>	<b>192.2</b>	<b>8.1</b>	<a href="#">WE5201800</a>	<b>183.74 x 3.53</b>
55.0	63.8	6.3	<a href="#">WE5100550</a>	58.42 x 2.62	<b>180.0*</b>	<b>196.0</b>	<b>9.5</b>	<a href="#">WE5301800</a>	<b>183.52 x 5.33</b>
<b>56.0*</b>	<b>64.8</b>	<b>6.3</b>	<a href="#">WE5100560</a>	<b>59.99 x 2.62</b>	188.2	204.2	9.5	<a href="#">WE5301882</a>	189.87 x 5.33
60.0	67.6	4.2	<a href="#">WE5000600</a>	63.17 x 2.62	190.0	206.0	9.5	<a href="#">WE5301900</a>	196.22 x 5.33
60.0	68.8	6.3	<a href="#">WE5100600</a>	63.17 x 2.62	<b>200.0*</b>	<b>212.2</b>	<b>8.1</b>	<a href="#">WE5202000</a>	<b>202.79 x 3.53</b>
<b>63.0*</b>	<b>71.8</b>	<b>6.3</b>	<a href="#">WE5100630</a>	<b>66.34 x 2.62</b>	<b>200.0*</b>	<b>216.0</b>	<b>9.5</b>	<a href="#">WE5302000</a>	<b>202.57 x 5.33</b>
65.0	73.8	6.3	<a href="#">WE5100650</a>	67.95 x 2.62	<b>220.0*</b>	<b>232.2</b>	<b>8.1</b>	<a href="#">WE5202200</a>	<b>221.84 x 3.53</b>
<b>70.0*</b>	<b>78.8</b>	<b>6.3</b>	<a href="#">WE5100700</a>	<b>72.69 x 2.62</b>	<b>220.0*</b>	<b>236.0</b>	<b>9.5</b>	<a href="#">WE5302200</a>	<b>221.62 x 5.33</b>
<b>70.0*</b>	<b>82.2</b>	<b>8.1</b>	<a href="#">WE5200700</a>	<b>75.79 x 3.53</b>	240.0	256.0	9.5	<a href="#">WE5302400</a>	247.02 x 5.33
75.0	87.2	8.1	<a href="#">WE5200750</a>	78.97 x 3.53	<b>250.0*</b>	<b>262.2</b>	<b>8.1</b>	<a href="#">WE5202500</a>	<b>253.59 x 3.53</b>
<b>80.0*</b>	<b>88.8</b>	<b>6.3</b>	<a href="#">WE5100800</a>	<b>82.22 x 2.62</b>	<b>250.0*</b>	<b>266.0</b>	<b>9.5</b>	<a href="#">WE5302500</a>	<b>253.37 x 5.33</b>
<b>80.0*</b>	<b>92.2</b>	<b>8.1</b>	<a href="#">WE5200800</a>	<b>85.32 x 3.53</b>	260.0	276.0	9.5	<a href="#">WE5302600</a>	266.07 x 5.33
85.0	97.2	8.1	<a href="#">WE5200850</a>	88.49 x 3.53	270.0	286.0	9.5	<a href="#">WE5302700</a>	278.77 x 5.33
<b>90.0*</b>	<b>98.8</b>	<b>6.3</b>	<a href="#">WE5100900</a>	<b>94.92 x 2.62</b>	<b>280.0*</b>	<b>292.2</b>	<b>8.1</b>	<a href="#">WE5202800</a>	<b>278.99 x 3.53</b>
<b>90.0*</b>	<b>102.2</b>	<b>8.1</b>	<a href="#">WE5200900</a>	<b>94.84 x 3.53</b>	<b>280.0*</b>	<b>296.0</b>	<b>9.5</b>	<a href="#">WE5302800</a>	<b>278.77 x 5.33</b>
92.5	104.7	8.1	<a href="#">WE5200925</a>	98.02 x 3.53	300.0	316.0	9.5	<a href="#">WE5303000</a>	304.17 x 5.33
95.0	107.2	8.1	<a href="#">WE5200950</a>	101.19 x 3.53	<b>320.0*</b>	<b>332.2</b>	<b>8.1</b>	<a href="#">WE5203200</a>	<b>329.79 x 3.53</b>
<b>100.0*</b>	<b>108.8</b>	<b>6.3</b>	<a href="#">WE5101000</a>	<b>101.27 x 2.62</b>	<b>320.0*</b>	<b>336.0</b>	<b>9.5</b>	<a href="#">WE5303200</a>	<b>329.57 x 5.33</b>
<b>100.0*</b>	<b>112.2</b>	<b>8.1</b>	<a href="#">WE5201000</a>	<b>104.37 x 3.53</b>	330.0	346.0	9.5	<a href="#">WE5303300</a>	329.57 x 5.33
105.0	117.2	8.1	<a href="#">WE5201050</a>	110.72 x 3.53	350.0	366.0	9.5	<a href="#">WE5303500</a>	354.97 x 5.33
<b>110.0*</b>	<b>118.8</b>	<b>6.3</b>	<a href="#">WE5101100</a>	<b>113.97 x 2.62</b>	<b>360.0*</b>	<b>372.2</b>	<b>8.1</b>	<a href="#">WE5203600</a>	<b>355.19 x 3.53</b>
<b>110.0*</b>	<b>122.2</b>	<b>8.1</b>	<a href="#">WE5201100</a>	<b>113.89 x 3.53</b>	<b>360.0*</b>	<b>376.0</b>	<b>9.5</b>	<a href="#">WE5303600</a>	<b>365.00 x 5.30</b>
115.0	127.2	8.1	<a href="#">WE5201150</a>	120.24 x 3.53	380.0	396.0	9.5	<a href="#">WE5303800</a>	380.37 x 5.33
120.0	132.2	8.1	<a href="#">WE5201200</a>	123.42 x 3.53	400.0	424.0	14.0	<a href="#">WE5404000</a>	405.26 x 7.00
<b>125.0*</b>	<b>133.8</b>	<b>6.3</b>	<a href="#">WE5101250</a>	<b>126.67 x 2.62</b>	440.0	464.0	14.0	<a href="#">WE5404400</a>	443.36 x 7.00
<b>125.0*</b>	<b>137.2</b>	<b>8.1</b>	<a href="#">WE5201250</a>	<b>129.77 x 3.53</b>	450.0	474.0	14.0	<a href="#">WE5404500</a>	456.06 x 7.00



<b>Rod Dia.</b>	<b>Groove Dia.</b>	<b>Groove Width</b>	<b>TSS Part No.</b>	<b>O-Ring Size</b>
<b>d<sub>N</sub></b> f8/h9	<b>D<sub>3</sub></b> H9	<b>L<sub>3</sub></b> +0.2		
480.0	504.0	14.0	<a href="#">WE5404800</a>	481.38 x 7.00
500.0	524.0	14.0	<a href="#">WE5405000</a>	506.86 x 7.00
560.0	584.0	14.0	<a href="#">WE5405600</a>	557.66 x 7.00
600.0	624.0	14.0	<a href="#">WE5406000</a>	608.08 x 7.00
650.0	677.3	16.0	<a href="#">WE5506500</a>	662 x 8.40
680.0	707.3	16.0	<a href="#">WE5506800</a>	692 x 8.40
700.0	727.3	16.0	<a href="#">WE5507000</a>	712 x 8.40
750.0	777.3	16.0	<a href="#">WE5507500</a>	762 x 8.40
800.0	827.3	16.0	<a href="#">WE5508000</a>	812 x 8.40
850.0	877.3	16.0	<a href="#">WE5508500</a>	862 x 8.40
900.0	927.3	16.0	<a href="#">WE5509000</a>	912 x 8.40
950.0	977.3	16.0	<a href="#">WE5509500</a>	962 x 8.40
1,000.0	1,027.3	16.0	<a href="#">WE55X1000</a>	1,012 x 8.40
1,800.0	1,827.3	16.0	<a href="#">WE55X1800</a>	1,812 x 8.40
2,600.0	2,627.3	16.0	<a href="#">WE55X2600</a>	2,612 x 8.40

The rod diameters in **bold** type comply with the recommendations of ISO 3320.

\* Installation in grooves according to ISO 6195 Type D



# Zurcon® Excluder® Z



---

Injection Molded

---

Rubber-energized Double-acting Scraper

---

**Material:**

Zurcon® Z13 and Elastomer

---







## ZURCON® EXCLUDER® Z



### Description

Zurcon® Excluder® Z is a new injection molded O-Ring energized double-acting scraper made from Zurcon® Z13 and fitting into 6195 type D grooves.

The O-Ring maintains the correct pressure on the lips and compensates for temperature conditions and rod deflection.

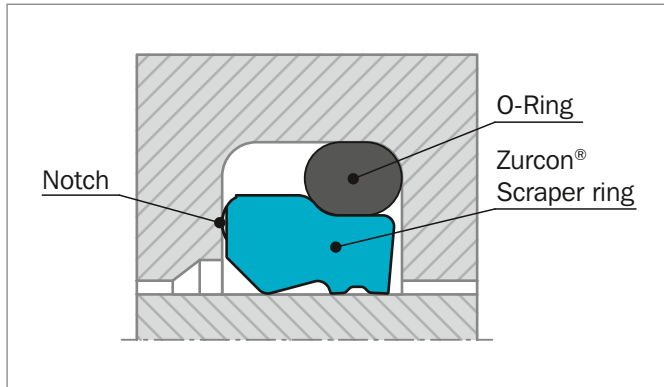

Figure 177: Zurcon® Excluder Z

The seal has three areas, each performing a specific task: scraping, sealing and support lip (see Figure 178).

Dividing each portion of the profile into several parts, it was possible to optimize angles and the radius to achieve each function while maintaining the stability necessary to cope with different application conditions.

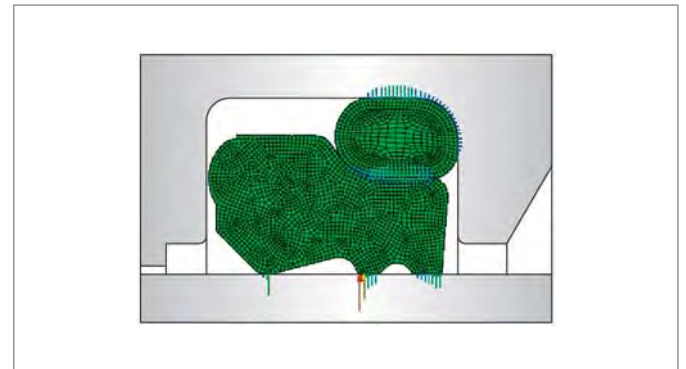

Figure 178: Contact pressure after assembly

Zurcon® Excluder® Z is designed to control fluid film during outstroke and instroke and is able to cope with hydraulic pressure coming from the system, provided it is used in combination with a primary or secondary seal with good back-pumping abilities like Zurcon® U-Cup RU9, Zurcon® L-Cup® or Zurcon® Rimseal.

Especially when used in tandem with a primary seal, this new design promises to give an effective solution for modern hydraulic applications.

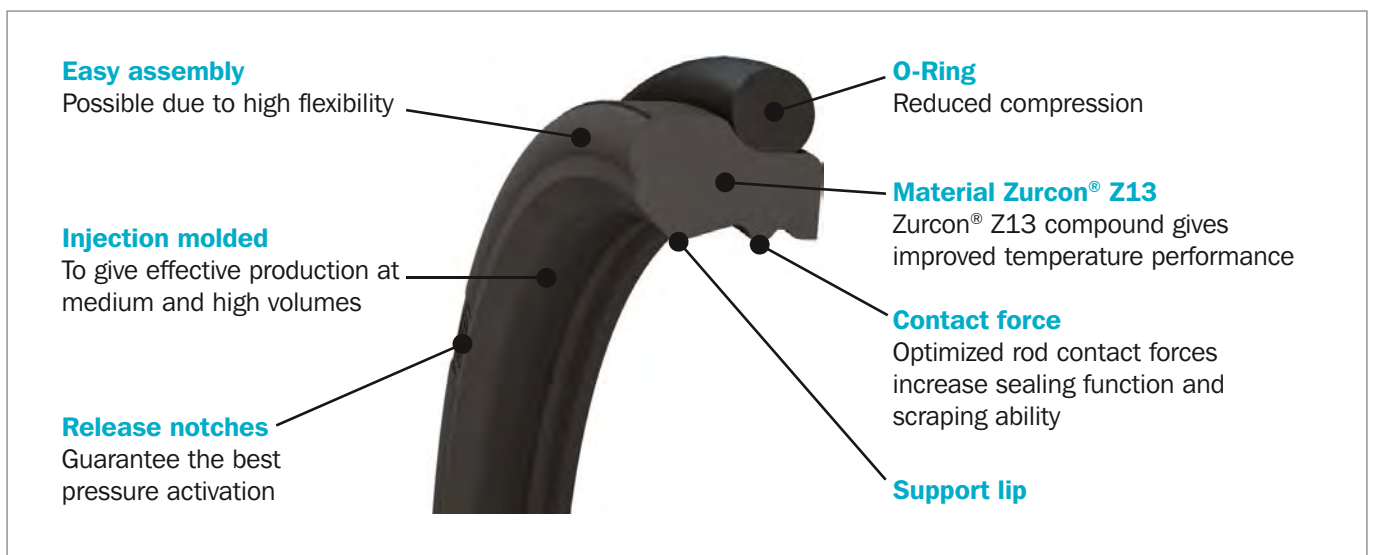

Figure 179: Zurcon® Excluder® Z design features



### METHOD OF OPERATION

Four release notches guarantee optimal pressure activation of the O-Ring even with poor tolerance combinations of groove, seal and temperature. In order to improve performance throughout a wide range of application conditions, stability in the groove is of critical importance. Zurcon® Excluder® Z has a very stable design due to:

- Equal scraping, sealing and support on the inner diameter
- Lower O-Ring compression

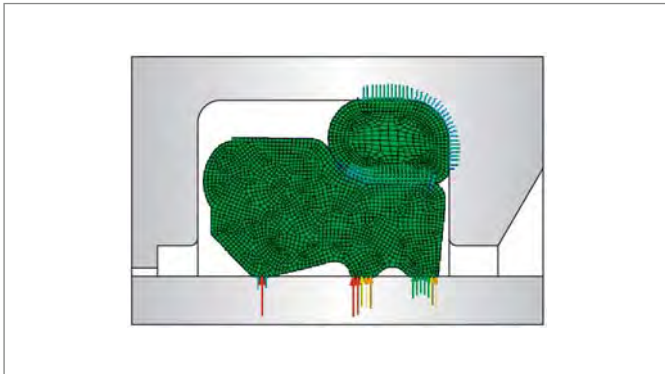

In accordance with the optimum sealing technology specifications, Zurcon® Excluder® Z is designed to control fluid film during outstroke and instroke, due to the optimized shape of the scraping lip and improved production process. The installation phase is also easier compared to other hard TPU compounds due to the Zurcon® Z13 compounds inherent elasticity, also removing the need for calibration after installation.

### ADVANTAGES

Zurcon® Excluder® Z has increased scraping and sealing capabilities from the optimized rod contact force distribution. Instead of Zurcon® Z05 used for previous scraper designs, Zurcon® Excluder® Z uses Zurcon® Z13 slipper pads that, owing to higher material flexibility, are much easier to assemble. Additionally, the compound also increases the temperature range up to +110 °C and greatly improves chemical compatibility with new generation hydraulic fluids.

Zurcon® Z13 is also available in injection molded tubes that allow machining of parts in low volumes and increases the diameter range above an injection machine's normal constraints.

Polyurethane materials have excellent abrasion resistance characteristics that guarantee a good scraping effect even in heavy-duty applications or when operating in harsh environments

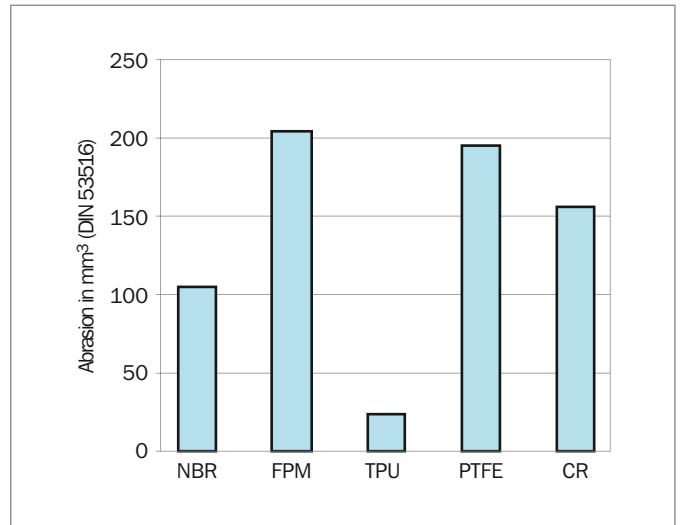

Figure 180: Comparison of abrasion resistance for different materials

Calibrated rod contact pressure and reduced friction when the oil film is controlled make Zurcon® Excluder® Z an excellent choice as a scraping element in Lubrication Management configurations.

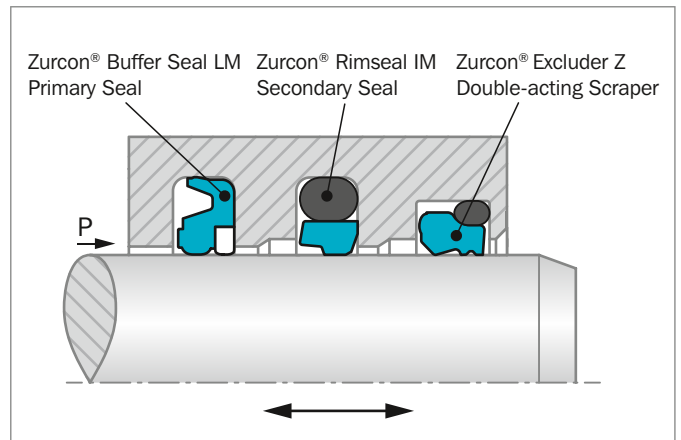

Figure 181: Tandem configuration



## APPLICATION EXAMPLES

Excellent abrasion resistance and high activation force from the compressed O-Ring provide high scraping efficiency and compensate for any deflections of the piston rod in harsh environments. The closed groove installation protects the lip from damage. Zurcon® Excluder® Z is recommended for medium- and heavy-duty applications:

- Construction machinery
- Earth moving equipment
- Mobile hydraulics
- Machine tools
- Truck cranes
- Fork lifts

## OPERATING CONDITIONS

<b>Speed:</b>	1 m/s
<b>Temperature:</b>	-45 °C to +110 °C depending on O-Ring material
<b>Media:</b>	Mineral oil, synthetic and natural esters, HEES/HETG up to +60 °C, flame retardant fluids HFA, special optimized for flame retardant fluids (HFC) up to +60 °C
<b>Installation:</b>	Standard mounting in closed grooves. For $\varnothing < 25$ mm request a split groove. No recalibration needed for installation in closed groove. ISO 6195 Type D installation dimensions from diameter 40 mm

### IMPORTANT NOTE

The above data are maximum values and cannot be used at the same time, e.g. the maximum operating speed depends on pressure, temperature and gap value. A combination of pressure and speed might cause local heat increases, so care should be taken when evaluating high values for the above parameters simultaneously.

## MATERIAL

Zurcon® Z13 is the 60 ShD TPU that combines excellent mechanical and elastic material properties:

- Temperature range from -45 ° to +110 °C
- (for short periods, up to +120°C)
- Good combination of elasticity and tensile strength
- Low friction
- Excellent chemical compatibility
- Low compression set at high temperatures

**Table 169: Material Recommendation**

Code	O-Ring Material Shore A	Code	O-Ring Temp. °C*
Z13	NBR 70	N	-30 to +100
	NBR 70 Low temp.	T	-45 to +80
	HNBR 70	H	-30 to +110
	FKM 70	V	-10 to (+200)

\* The O-Ring operation temperature is only valid in hydraulic mineral oil.

**Table 170: Z13 Chemical compatibility: General guideline (Laboratory compatibility tests 1,008 hours)**

FLUIDS TYPE	DIN / ISO Code	Temperatur	Result
Mineral Oils	HLP	+110 °C	Excellent
	HVLP		
	HLPD		
Synthetics fluids	HEES	+80 °C to +100 °C	Excellent
	HEPG (PAG)	+60 °C	Good
	HEPR (PAO)	+100 °C	Excellent
Water based fluids	HFA	+60 °C to +60 °C	Good
	HFC	+600 °C	Excellent
Synthetics water free fluids	HFDU	+100 °C	Excellent

The above results must be considered as general guidelines. We recommend verifying the compound compatibility with the specific fluids and temperature conditions experienced in the application.



## Installation Recommendation

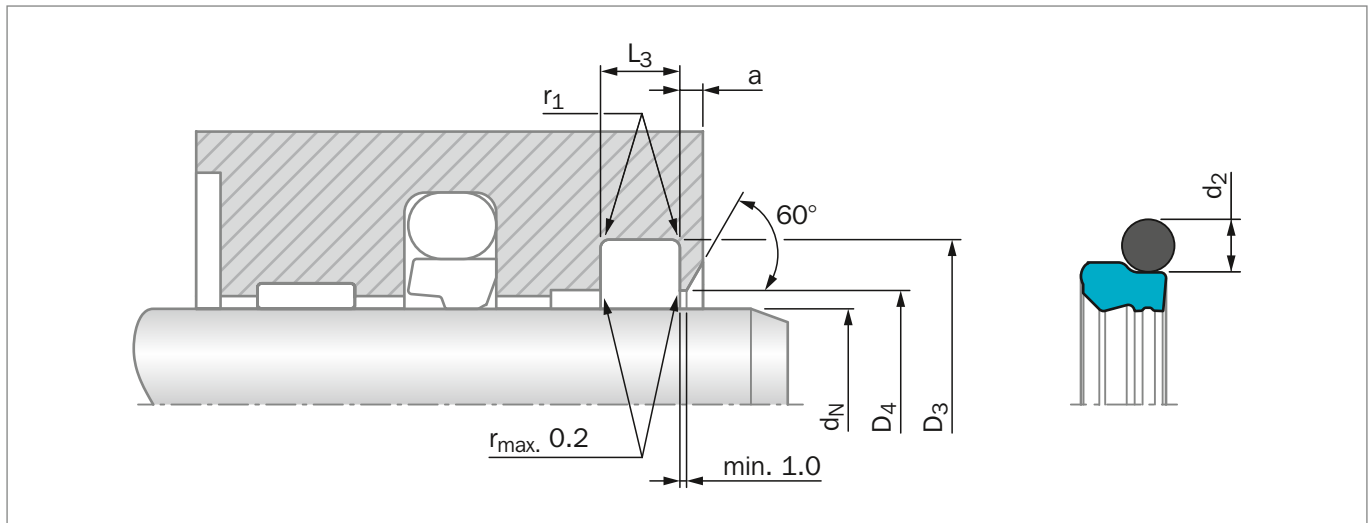

Figure 182: Installation Drawing

**Table 171: Installation Dimensions – Standard Recommendations**

Series No.	Rod Diameter $d_N$ f8/h9		Groove Diameter	Groove Width	Bore Diameter	Step Width	Radius	O-Ring Cross Section
	Standard Application	Available Range	$D_3$ H11	$L_3$ +0.2	$D_4$ H11	$a_{min}$	$r_1$ max	$d_2$
WEB0	19 – 39.9	19 – 100.0	$d_N + 7.3$	4.2	$d_N + 1.5$	3.0	0.8	2.62
WEB1	40 – 69.9	30 – 200.0	$d_N + 8.8$	6.3	$d_N + 1.5$	3.0	1.0	2.62
WEB2	70 – 139.9	70 – 360.0	$d_N + 12.2$	8.1	$d_N + 2.0$	4.0	1.0	3.53
WEB3	140 – 399.9*	100 – 399.9*	$d_N + 16.0$	9.5	$d_N + 2.5$	5.0	1.5	5.33

\* max. diameter for Zurcon® Z13 injection molded tubes for machining is 423 mm OD

### ORDERING EXAMPLE

Zurcon® Excluder Z complete with O-Ring:

<b>Rod Diameter:</b>	$d_N = 50.0$ mm
<b>Groove Width:</b>	$L_1 = 6.3$ mm
<b>TSS Part No.:</b>	WEB100500

<b>TSS Article No.</b>	<b>WEB1</b>	<b>0</b>	<b>0500</b>	<b>-</b>	<b>Z13</b>	<b>N</b>
TSS Series No.	_____	_____	_____	_____	_____	_____
Type (Standard)	_____	_____	_____	_____	_____	_____
Rod Diameter x 10	_____	_____	_____	_____	_____	_____
Quality Index (Standard)	_____	_____	_____	_____	_____	_____
Material Code (Scraper)	_____	_____	_____	_____	_____	_____
Material Code (O-Ring)	_____	_____	_____	_____	_____	_____



Table 172: Installation Dimensions / TSS Part No.

Rod Diameter	Groove Diameter	Groove Width	Radius	TSS Part No.	O-Ring Size
$d_N$ f8/h9	$D_1$ H9	$L_3$ +0.2	$D_4$ H11		
<b>22.0</b>	<b>29.6</b>	<b>4.2</b>	<b>23.5</b>	<b>WEB000220-Z13</b>	<b>25.07 x 2.62</b>
<b>25.0</b>	<b>32.6</b>	<b>4.2</b>	<b>26.5</b>	<b>WEB000250-Z13</b>	<b>28.24 x 2.62</b>
<b>28.0</b>	<b>35.6</b>	<b>4.2</b>	<b>29.5</b>	<b>WEB000280-Z13</b>	<b>29.82 x 2.62</b>
30.0	37.6	4.2	31.5	WEB000300-Z13	32.99 x 2.62
35.0	42.6	4.2	36.5	WEB000350-Z13	37.77 x 2.62
<b>*40.0</b>	<b>48.8</b>	<b>6.3</b>	<b>41.5</b>	<b>WEB100400-Z13</b>	<b>44.12 x 2.62</b>
<b>*45.0</b>	<b>53.8</b>	<b>6.3</b>	<b>46.5</b>	<b>WEB100450-Z13</b>	<b>48.90 x 2.62</b>
<b>*50.0</b>	<b>58.8</b>	<b>6.3</b>	<b>51.5</b>	<b>WEB100500-Z13</b>	<b>53.64 x 2.62</b>
60.0	68.8	6.3	61.5	WEB100600-Z13	63.17 x 2.62
65.0	73.8	6.3	66.5	WEB100650-Z13	67.95 x 2.62
<b>*70.0</b>	<b>82.2</b>	<b>8.1</b>	<b>72.0</b>	<b>WEB200700-Z13</b>	<b>75.79 x 3.53</b>
<b>*80.0</b>	<b>92.2</b>	<b>8.1</b>	<b>82.0</b>	<b>WEB200800-Z13</b>	<b>85.32 x 3.53</b>
85.0	97.2	8.1	87.0	WEB200850-Z13	88.49 x 3.53
<b>*90.0</b>	<b>102.2</b>	<b>8.1</b>	<b>92.0</b>	<b>WEB200900-Z13</b>	<b>94.84 x 3.53</b>
95.0	107.2	8.1	97.0	WEB200950-Z13	101.19 x 3.53
<b>*100.0</b>	<b>112.2</b>	<b>8.1</b>	<b>102.0</b>	<b>WEB201000-Z13</b>	<b>104.37 x 3.53</b>
105.0	117.2	8.1	107.0	WEB201050-Z13	110.72 x 3.53
<b>*110.0</b>	<b>122.2</b>	<b>8.1</b>	<b>112.0</b>	<b>WEB201100-Z13</b>	<b>113.89 x 3.53</b>
<b>*125.0</b>	<b>137.2</b>	<b>8.1</b>	<b>127.0</b>	<b>WEB201250-Z13</b>	<b>129.77 x 3.53</b>

All dimensions in **bold** type are in accordance with recommendations of ISO 3320

\* installation in grooves according to ISO 6195 Type D

---

! This page is intentionally left blank.



# Turcon® Excluder® F



---

Double-acting

---

Rubber-energized Double-acting Scraper

**Material:**

Turcon®, Zurcon® and Elastomer

---







## Turcon® Excluder® F

### Description



Turcon® Excluder® F is a double-acting scraper with scraper lip and sealing lip, positioned back-to-back. The scraper is always installed with 2 O-Rings as elastic energizing elements in one groove. The scraper function itself is performed by the Excluder® F Turcon® element. The O-Rings maintains the pressure of the scraper lips against the sliding surface and compensates deflections of the piston rod.

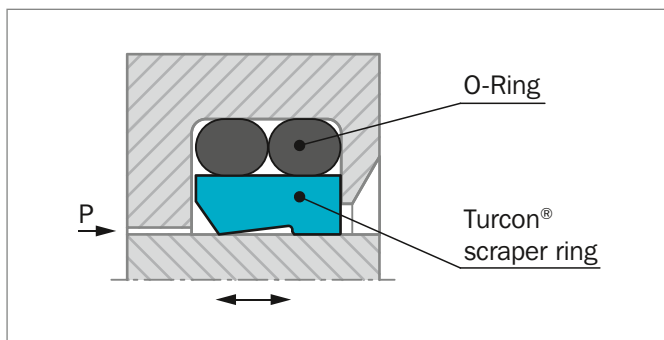

Figure 183: Turcon® Excluder® F

### EXCLUDER® F HAS TWO FUNCTIONS:

- Scrape contaminants from the retracting piston rod to protect the system from soiling
- Hold back the residual oil film on the extending piston rod on the medium side.
- Excluder® F is preferably used in conjunction with our rod seals Turcon® Stepseal® 2K or Zurcon® Rimseal, i.e. seals with a hydrodynamic back-pumping function. Application wise the Excluder® F is placed between Excluder® 2 and Excluder® 5 for medium to "light-heavy" duty such as in:
  - Light construction machinery
  - Truck crane
  - Agriculture machines
  - Hydraulic presses
  - Injection molding machines
  - Hydraulic actuators

### ADVANTAGES

In principle the same as for Excluder® 2 and 5:

- Outstanding sliding properties
- Stick-slip-free, no sticking for Turcon® materials
- Tough scraper particular in Zurcon® materials
- Can compensate for deflections of the piston rod or plunger
- Very good scraping effect even against firmly adhered dirt, etc.
- Very good sealing effect from the inside against the residual oil film adhering to the surface of the piston rod
- Identical installation as Zurcon® Excluder® 500 and Excluder® 5 from WE50 to WE52
- Very high resistance to hydraulic media
- Available for diameters from 19 up to 1,500 mm
- ISO 6195 Type D installation on recommended diameters from 40 to 140 mm

### DISADVANTAGES COMPARED TO EXCLUDER® 2 AND 5

- Require 2 pcs O-Rings
- Not completely axially locked in the groove
- More disposed to wrong installation

### ADVANTAGES COMPARED TO EXCLUDER® 2 AND 5

- Easy installation in closed groove
- Improved radial flexibility
- Improved sealing function due to O-Ring arrangement



## OPERATING CONDITIONS

<b>Speed:</b>	15 m/s for Turcon® materials 2 m/s for Zurcon® Z80 materials 1 m/s for Zurcon® Z53/Z54 materials
<b>Temperature:</b>	-45 °C to +200 °C (Turcon® ) -60 °C to +80 °C (Zurcon® Z80) -45 °C to +110 °C (Zurcon® Z53/Z54) depending on O-Ring materials
<b>Media:</b>	Mineral oil-based hydraulic fluids, flame retardant hydraulic fluids, environmentally friendly hydraulic fluids (bio-oils), phosphate ester, water, air and others, depending on scraper and O-ring material compatibility.

### IMPORTANT NOTE

The above data are maximum values and cannot be used at the same time, e.g. the maximum operating speed depends on material type, environment, temperature and media.

## INSTALLATION INSTRUCTIONS

All Excluder® F scrapers are preferably installed in closed grooves - installation dimensions see Table 174.

## MATERIALS

The following material combinations have proven effective for most applications:

### Turcon® Excluder® F in Turcon® M12

All round material for hydraulic applications with linear, short stroke or helical movements in mineral oils, flame retardant hydraulic fluids, phosphate ester, bio-oils or fluids having low lubricating properties:

O-Ring:	NBR 70 Shore A	N
	FKM 70 Shore A	V

Set code: M12N or M12V

### Turcon® Excluder® F in Turcon® T46

For medium to heavy applications with linear movements in mineral oils and other media with good lubrication:

O-Ring:	NBR 70 Shore A	N
	FKM 70 Shore A	V

Set code: T46N or T46V

For specific applications, all Turcon® materials are available.

Other material combinations are listed in Table 173.

**Table 173: Turcon® and Zurcon® Materials for Excluder® F**

Material, Applications, Properties	Code	O-Ring Material Shore A	Code	O-Ring Operating Temp. * °C	Mating Surface Material	Speed max. m/s
<b>Turcon® M12</b> First material choice for linear motion Overall improved properties For new constructions and updating For all commonly applied hydraulic fluids including fluids with low lubrication performance Lowest friction and best sliding properties Lowest wear on scrapers Improved absorption of abrasive contaminants Low wear or abrasion of counter surface BAM tested Mineral fiber and Additives filled Color: Dark gray	M12	NBR 70	N	-30 to +100	Steel	15
		NBR 70 Low temp.	T	-45 to +80	Steel, hardened Steel, chrome plated (rod)	
		FKM 70	V	-10 to +200	Steel plated (rod) Cast iron Stainless steel Titanium	
<b>Turcon® T40</b> For lubricating and non-lubricating fluids High frequency and short strokes Water hydraulics Surface texture is not suitable for gas Carbon fiber filled Color: Gray	T40	NBR 70	N	-30 to +100	Steel	15
		NBR 70 Low temp.	T	-45 to +80	Steel, chrome plated (rod) Cast iron	
		FKM 70	V	-10 to +200	Stainless steel	
		EPDM 70	E**	-45 to +145	Aluminum	
<b>Turcon® T46</b> For lubricated hydraulics in linear motion High compressive strength High extrusion resistance Very good sliding and wear properties BAM tested Bronze filled Color: Light to dark brown, which may have variations in shading.	T46	NBR 70	N	-30 to +100	Steel, hardened	15
		NBR 70 Low temp.	T	-45 to +80	Steel, chrome plated (rod) Cast iron	
		FKM 70	V	-10 to +200		
<b>Zurcon® Z53</b> For mineral oil based fluids Very high abrasion and extrusion resistance For counter surface with rougher surface finish More difficult to install Limited chemical resistance Max. working temperature +110 °C Cast polyurethane Color: Yellow to light-brown	Z53	NBR 70	N	-30 to +100	Steel	1
		NBR 70 Low temp.	T	-45 to +80	Steel, hardened Steel chrome plated (rod) Cast iron Ceramic coating Stainless steel	

Table continues on next page



Material, Applications, Properties	Code	O-Ring Material Shore A	Code	O-Ring Operating Temp.* °C	Mating Surface Material	Speed max. m/s
<b>Zurcon® Z54</b> For mineral oil based fluids High abrasion resistance For counter surface with rougher surface finishes Good extrusion resistance Limited chemical resistance Max. working temperature +110 °C Cast polyurethane Color: Turquoise	<b>Z54</b>	NBR 70	N	-30 to +100	Steel	1
		NBR 70 Low temp.	T	-45 to +80	Steel, hardened Steel, chrome plated (rod) Cast iron Stainless steel Aluminum Ceramic coating	
<b>Zurcon® Z80</b> For lubricating and non-lubricating fluids Water based fluids, air and gases Dry air pneumatics High abrasion and extrusion resistance For service in abrasive conditions and media with particles Good chemical resistance Limited temperature capability (-60 to +80 °C) UHMWPE (Ultra High Molecular Weight Polyethylene)	<b>Z80</b>	NBR 70	N	-30 to +100	Steel	2
		NBR 70 Low temp.	T	-45 to +80	Steel, chrome plated (rod) Stainless steel	
		EPDM 70	E**	-45 to +145	Aluminum Ceramic coating	

\* The O-Ring Operation Temperature is only valid in mineral hydraulic oil, except EPDM.

\*\* Material not suitable for mineral oils.

BAM: Tested by "Bundesanstalt Materialprüfung, Germany".

  Highlighted materials are recommended.



## Installation Recommendation

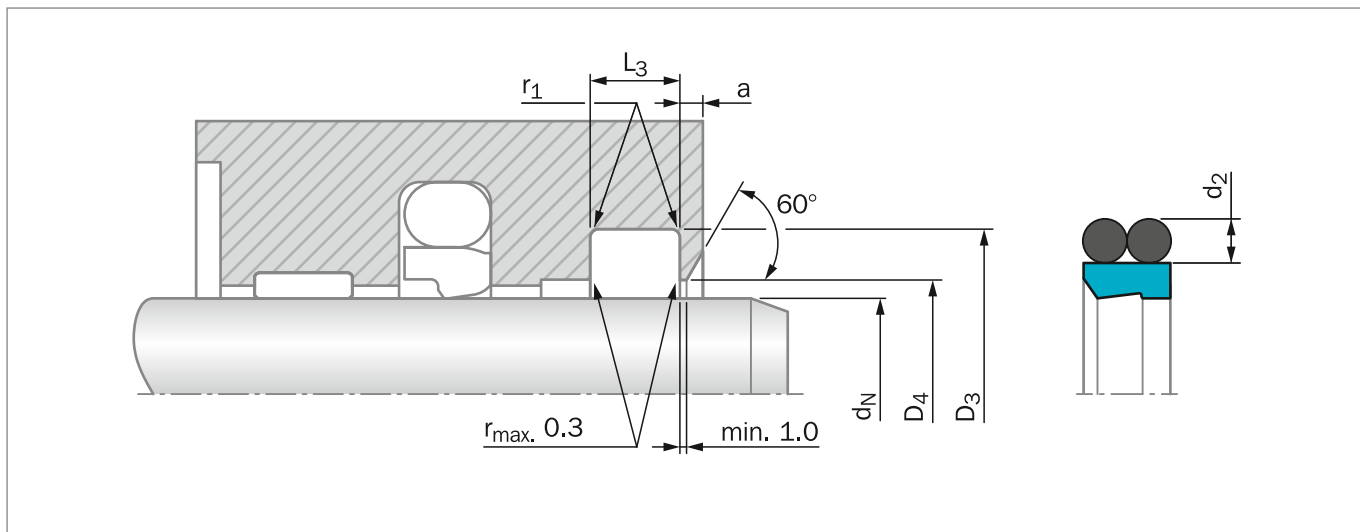

Figure 184: Installation Drawing

**Table 174: Installation Dimensions – Standard Recommendations**

Series No.	Rod $d_N$ f8/h9		Groove Diameter $D_3$ H9	Groove Width $L_3$ +0.2	Bore Diameter $D_4$ H11	Step Width $a_{min}$	Radius $r_1$ max	O-Ring Cross Section $d_2$
	Standard Application	Available Range						
WEF0	19 - 39.9	19 - 130	$d_N + 7.6$	4.2	$d + 1.0$	3.0	0.4	1.78
WEF1	40 - 69.9	30 - 250	$d_N + 8.8$	6.3	$d + 1.5$	3.0	1.0	2.62
WEF2	70 - 139.9	50 - 450	$d_N + 12.2$	8.1	$d + 2.0$	5.0	1.2	3.53
WEF3	140 - 399.9	80 - 650	$d_N + 16.0$	11.5	$d + 2.0$	5.0	2.0	5.33
WEF4	400 - 649.9	180 - 650	$d_N + 24.0$	15.5	$d + 2.5$	8.0	2.5	7.00
WEF5	650 - 999.9	300 - 999.9	$d_N + 27.3$	18.0	$d + 2.5$	10.0	2.5	8.40
WEF5X	1,000 - 1,500		$d_N + 27.3$	18.0	$d + 2.5$	10.0	2.5	8.40

### ORDERING EXAMPLE

Turcon® Excluder® F complete with O-Ring, standard application:

<b>Series:</b>	WEF1 from Table 174
<b>Rod Diameter:</b>	$d_N = 50.0$ mm
<b>TSS Part No.:</b>	WEF100500 from Table 175

Select the material from Table 173. The corresponding code numbers are appended to the TSS Part No. Together these form the TSS Article Number. The TSS Article Number for all intermediate sizes can be determined by following the example:

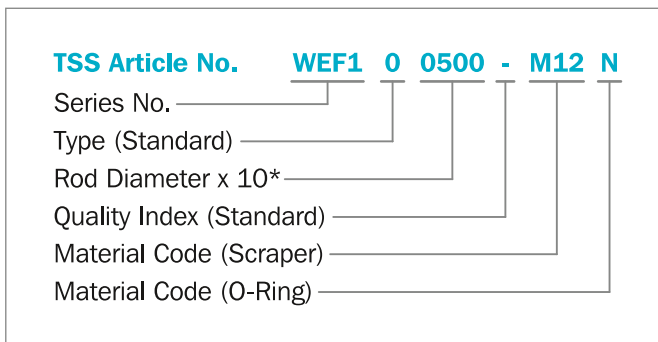

\* For diameters  $d_N \geq 1,000.0$  mm multiply only by factor 1.  
 Example: WEF5 for diameter  $d_N = 1,200.0$  mm  
 TSS Article No.: WEF5X1200-M12N



**Table 175: Installation Dimensions / TSS Part Numbers**

Rod Dia.	Groove Dia.	Groove Width	TSS Part No.	O-Ring Size	Rod Dia.	Groove Dia.	Groove Width	TSS Part No.	O-Ring Size
d <sub>N</sub> f8/h9	D <sub>3</sub> H9	L <sub>3</sub> +0.2			d <sub>N</sub> f8/h9	D <sub>3</sub> H9	L <sub>3</sub> +0.2		
19.0	26.6	4.2	<a href="#">WEF000190</a>	23.52 x 1.78	125.4	137.6	8.1	<a href="#">WEF201254</a>	129.77 x 3.53
<b>20.0</b>	<b>27.6</b>	<b>4.2</b>	<a href="#">WEF000200</a>	<b>23.52 x 1.78</b>	130.0	142.2	8.1	<a href="#">WEF201300</a>	136.12 x 3.53
<b>22.0</b>	<b>29.6</b>	<b>4.2</b>	<a href="#">WEF000220</a>	<b>26.70 x 1.78</b>	135.0	147.2	8.1	<a href="#">WEF201350</a>	139.29 x 3.53
<b>25.0</b>	<b>32.6</b>	<b>4.2</b>	<a href="#">WEF000250</a>	<b>28.30 x 1.78</b>	<b>140.0*</b>	<b>152.2</b>	<b>8.1</b>	<a href="#">WEF201400</a>	<b>145.64 x 3.53</b>
<b>28.0</b>	<b>35.6</b>	<b>4.2</b>	<a href="#">WEF000280</a>	<b>31.47 x 1.78</b>	<b>140.0*</b>	<b>156.0</b>	<b>11.5</b>	<a href="#">WEF301400</a>	<b>145.42 x 5.33</b>
30.0	37.6	4.2	<a href="#">WEF000300</a>	34.65 x 1.78	140.5	156.5	11.5	<a href="#">WEF301405</a>	145.42 x 5.33
<b>32.0</b>	<b>39.6</b>	<b>4.2</b>	<a href="#">WEF000320</a>	<b>34.65 x 1.78</b>	150.0	166.0	11.5	<a href="#">WEF301500</a>	151.77 x 5.33
35.0	42.6	4.2	<a href="#">WEF000350</a>	37.82 x 1.78	153.0	169.0	11.5	<a href="#">WEF301530</a>	158.12 x 5.33
<b>36.0</b>	<b>43.6</b>	<b>4.2</b>	<a href="#">WEF000360</a>	<b>41.00 x 1.78</b>	155.0	171.0	11.5	<a href="#">WEF301550</a>	158.12 x 5.33
<b>40.0*</b>	<b>48.8</b>	<b>6.3</b>	<a href="#">WEF100400</a>	<b>44.12 x 2.62</b>	<b>160.0*</b>	<b>172.2</b>	<b>8.1</b>	<a href="#">WEF201600</a>	<b>164.69 x 3.53</b>
42.0	50.8	6.3	<a href="#">WEF100420</a>	45.69 x 2.62	<b>160.0*</b>	<b>176.0</b>	<b>11.5</b>	<a href="#">WEF301600</a>	<b>164.47 x 5.33</b>
<b>45.0*</b>	<b>53.8</b>	<b>6.3</b>	<a href="#">WEF100450</a>	<b>48.90 x 2.62</b>	165.0	181.0	11.5	<a href="#">WEF301650</a>	170.82 x 5.33
48.0	56.8	6.3	<a href="#">WEF100480</a>	52.07 x 2.62	170.0	186.0	11.5	<a href="#">WEF301700</a>	177.17 x 5.33
<b>50.0*</b>	<b>58.8</b>	<b>6.3</b>	<a href="#">WEF100500</a>	<b>53.64 x 2.62</b>	175.0	191.0	11.5	<a href="#">WEF301750</a>	177.17 x 5.33
52.0	60.8	6.3	<a href="#">WEF100520</a>	55.25 x 2.62	<b>180.0*</b>	<b>192.2</b>	<b>8.1</b>	<a href="#">WEF201800</a>	<b>183.74 x 3.53</b>
55.0	63.8	6.3	<a href="#">WEF100550</a>	58.42 x 2.62	<b>180.0*</b>	<b>196.0</b>	<b>11.5</b>	<a href="#">WEF301800</a>	<b>183.52 x 5.33</b>
<b>56.0*</b>	<b>64.8</b>	<b>6.3</b>	<a href="#">WEF100560</a>	<b>59.99 x 2.62</b>	188.2	204.2	11.5	<a href="#">WEF301882</a>	189.87 x 5.33
60.0	67.6	4.2	<a href="#">WEF000600</a>	63.22 x 1.78	190.0	206.0	11.5	<a href="#">WEF301900</a>	196.22 x 5.33
60.0	68.8	6.3	<a href="#">WEF100600</a>	63.17 x 2.62	<b>200.0*</b>	<b>212.2</b>	<b>8.1</b>	<a href="#">WEF202000</a>	<b>202.79 x 3.53</b>
<b>63.0*</b>	<b>71.8</b>	<b>6.3</b>	<a href="#">WEF100630</a>	<b>66.34 x 2.62</b>	<b>200.0*</b>	<b>216.0</b>	<b>11.5</b>	<a href="#">WEF302000</a>	<b>202.57 x 5.33</b>
65.0	73.8	6.3	<a href="#">WEF100650</a>	67.95 x 2.62	<b>220.0*</b>	<b>232.2</b>	<b>8.1</b>	<a href="#">WEF202200</a>	<b>221.84 x 3.53</b>
<b>70.0*</b>	<b>78.8</b>	<b>6.3</b>	<a href="#">WEF100700</a>	<b>72.69 x 2.62</b>	<b>220.0*</b>	<b>236.0</b>	<b>11.5</b>	<a href="#">WEF302200</a>	<b>221.62 x 5.33</b>
<b>70.0*</b>	<b>82.2</b>	<b>8.1</b>	<a href="#">WEF200700</a>	<b>75.79 x 3.53</b>	240.0	256.0	11.5	<a href="#">WEF302400</a>	247.02 x 5.33
75.0	87.2	8.1	<a href="#">WEF200750</a>	78.97 x 3.53	<b>250.0*</b>	<b>262.2</b>	<b>8.1</b>	<a href="#">WEF202500</a>	<b>253.59 x 3.53</b>
<b>80.0*</b>	<b>88.8</b>	<b>6.3</b>	<a href="#">WEF100800</a>	<b>82.22 x 2.62</b>	<b>250.0*</b>	<b>266.0</b>	<b>11.5</b>	<a href="#">WEF302500</a>	<b>253.37 x 5.33</b>
<b>80.0*</b>	<b>92.2</b>	<b>8.1</b>	<a href="#">WEF200800</a>	<b>85.32 x 3.53</b>	260.0	276.0	11.5	<a href="#">WEF302600</a>	266.07 x 5.33
85.0	97.2	8.1	<a href="#">WEF200850</a>	88.49 x 3.53	270.0	286.0	11.5	<a href="#">WEF302700</a>	278.77 x 5.33
<b>90.0*</b>	<b>98.8</b>	<b>6.3</b>	<a href="#">WEF100900</a>	<b>94.92 x 2.62</b>	<b>280.0*</b>	<b>292.2</b>	<b>8.1</b>	<a href="#">WEF202800</a>	<b>278.99 x 3.53</b>
<b>90.0*</b>	<b>102.2</b>	<b>8.1</b>	<a href="#">WEF200900</a>	<b>94.84 x 3.53</b>	<b>280.0*</b>	<b>296.0</b>	<b>11.5</b>	<a href="#">WEF302800</a>	<b>278.77 x 5.33</b>
92.5	104.7	8.1	<a href="#">WEF200925</a>	98.02 x 3.53	300.0	316.0	11.5	<a href="#">WEF303000</a>	304.17 x 5.33
95.0	107.2	8.1	<a href="#">WEF200950</a>	101.19 x 3.53	<b>320.0*</b>	<b>332.2</b>	<b>8.1</b>	<a href="#">WEF203200</a>	<b>329.79 x 3.53</b>
<b>100.0*</b>	<b>108.8</b>	<b>6.3</b>	<a href="#">WEF101000</a>	<b>101.27 x 2.62</b>	<b>320.0*</b>	<b>336.0</b>	<b>11.5</b>	<a href="#">WEF303200</a>	<b>329.57 x 5.33</b>
<b>100.0*</b>	<b>112.2</b>	<b>8.1</b>	<a href="#">WEF201000</a>	<b>104.37 x 3.53</b>	330.0	346.0	11.5	<a href="#">WEF303300</a>	329.57 x 5.33
105.0	117.2	8.1	<a href="#">WEF201050</a>	110.72 x 3.53	350.0	366.0	11.5	<a href="#">WEF303500</a>	354.97 x 5.33
<b>110.0*</b>	<b>118.8</b>	<b>6.3</b>	<a href="#">WEF101100</a>	<b>113.97 x 2.62</b>	<b>360.0*</b>	<b>372.2</b>	<b>8.1</b>	<a href="#">WEF203600</a>	<b>355.19 x 3.53</b>
<b>110.0*</b>	<b>122.2</b>	<b>8.1</b>	<a href="#">WEF201100</a>	<b>113.89 x 3.53</b>	<b>360.0*</b>	<b>376.0</b>	<b>11.5</b>	<a href="#">WEF303600</a>	<b>365.00 x 5.30</b>
115.0	127.2	8.1	<a href="#">WEF201150</a>	120.24 x 3.53	380.0	396.0	11.5	<a href="#">WEF303800</a>	380.37 x 5.33
120.0	132.2	8.1	<a href="#">WEF201200</a>	123.42 x 3.53	400.0	424.0	15.5	<a href="#">WEF404000</a>	405.26 x 7.00
<b>125.0*</b>	<b>133.8</b>	<b>6.3</b>	<a href="#">WEF101250</a>	<b>126.67 x 2.62</b>	440.0	464.0	15.5	<a href="#">WEF404400</a>	443.36 x 7.00
<b>125.0*</b>	<b>137.2</b>	<b>8.1</b>	<a href="#">WEF201250</a>	<b>129.77 x 3.53</b>	450.0	474.0	15.5	<a href="#">WEF404500</a>	456.06 x 7.00





<b>Rod Dia.</b>	<b>Groove Dia.</b>	<b>Groove Width</b>	<b>TSS Part No.</b>	<b>O-Ring Size</b>
<b>d<sub>N</sub></b> f8/h9	<b>D<sub>3</sub></b> H9	<b>L<sub>3</sub></b> +0.2		
480.0	504.0	15.5	<a href="#">WEF404800</a>	481.38 x 7.00
500.0	524.0	15.5	<a href="#">WEF405000</a>	506.86 x 7.00
550.0	574.0	15.5	<a href="#">WEF405500</a>	557.66 x 7.00
600.0	624.0	15.5	<a href="#">WEF406000</a>	608.08 x 7.00
650.0	677.3	18.0	<a href="#">WEF506500</a>	662 x 8.40
700.0	727.3	18.0	<a href="#">WEF507000</a>	712 x 8.40
750.0	777.3	18.0	<a href="#">WEF507500</a>	762 x 8.40
800.0	827.3	18.0	<a href="#">WEF508000</a>	812 x 8.40
900.0	927.3	18.0	<a href="#">WEF509000</a>	912 x 8.40
<b>1,000.0</b>	<b>1,027.3</b>	18.0	<a href="#">WEF5X1000</a>	1,012 x 8.40
<b>1,100.0</b>	<b>1,127.3</b>	18.0	<a href="#">WEF5X1100</a>	1,112 x 8.40
<b>1,200.0</b>	<b>1,227.3</b>	18.0	<a href="#">WEF5X1200</a>	1,212 x 8.40

The rod diameters in **bold** type comply with the recommendations of ISO 3320.

\* Installation in grooves according to ISO 6195 Type D

Other dimensions and all intermediate sizes up to 1,500 mm diameter including imperial (inch) sizes can be supplied upon request.

---

ⓘ This page is intentionally left blank.

# Turcon® Excluder® S



---

Double-acting

---

Rubber-energized Double-acting Scraper

**Material:**

Turcon®, Zurcon®, Elastomer and Metal

---







## ■ Turcon® Excluder® S



### ■ Description

Turcon® Excluder® S is a double-acting scraper with scraper lip and sealing lip, positioned back-to-back. Excluder® S element is as standard always installed with a metal V-Spring and an O-Ring.

The V-Spring in the external part maintains a permanent pressure on the scraping edge. The internal O-Ring activates the sealing lip.

The V-Spring is filled with high temperature silicone to prevent contamination blocking the spring.

The conical front guides contamination away from the reciprocating rod. This is especially important when the piston rod is pointing upwards.

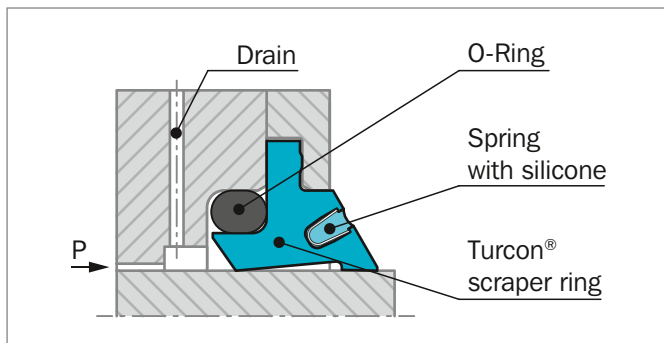

Figure 185: Turcon® Excluder® S with V-Spring activated lip

### EXCLUDER® S HAS TWO FUNCTIONS:

- Scrape contaminants from the retracting piston rod protecting the system from soiling
- Hold back the residual fluid film on the extending piston rod at the fluid side.

### APPLICATIONS

Excluder® S is preferably used in very dirty environments where it is mandatory to prevent moisture and contaminants from being trapped in front of the scraper element e.g. when the rod is pointing upwards, typically for bigger rod diameters in applications like:

- Mining equipment
- Hydraulic presses
- Steelworks
- Heavy construction machinery
- Marine constructions
- Offshore installations
- Water works

### ADVANTAGES

- No dirt trapping because of spring activated conical scraping lip
- Outstanding sliding properties
- Stick-slip-free, no sticking (for Turcon® materials)
- Good scraping effect even against firmly adhered dirt, etc.
- Good sealing effect from the inside against the residual fluid film adhering to the surface of the piston rod
- Clamped installation prevents particles and moisture to pass between Excluder® and cylinder head
- Very high resistance to hydraulic media
- Available for diameters from 40 up to 2,600 mm (Turcon®), up to 2,200 mm (Zurcon® Z53/Z54), up to 1,000 mm (Zurcon® Z82)



## OPERATING CONDITIONS

<b>Movement:</b>	Linear respectively low speed rotary service
<b>Back-Pressure:</b>	Up to 1.5 MPa drain line between rod seals and Excluder® is recommended
<b>Speed linear:</b>	15 m/s for Turcon® materials 2 m/s for Zurcon® Z80/Z82 materials 1 m/s for Zurcon® Z53/Z54 materials
<b>Temperature:</b>	-45 °C to +200 °C (Turcon®) -45 °C to +110 °C (Zurcon® Z53 / Z54) -60 °C to +80 °C (Zurcon® Z80/Z82) depending on O-Ring material
<b>Media:</b>	Mineral oil-based hydraulic fluids, flame retardant hydraulic fluids, environmentally friendly hydraulic fluids (bio-oils), phosphate ester, water, air and others, depending on scraper ring and O-Ring material compatibility.

## IMPORTANT NOTE

The above data are maximum values and cannot be used at the same time, e.g. the maximum operating speed depends on material type, pressure, temperature and gap value. Temperature range also depends on media.

## INSTALLATION INSTRUCTIONS

Excluder® S is always installed in split housing grooves.

Housing dimensions, radial clearances and recommended Excluder® S series in relation to diameter are as illustrated in Table 177.

Installation should be performed in the following steps in order to ensure a concentric and stress-free fit:

- Insert the O-Ring in the groove
- Place the Excluder® Ring into the open groove
- Fit the cover loosely onto the housing
- Insert the rod - check whether rod has the recommended lead-in chamfer; if not, use a calibration mandrel - see Figure 186 **point 1**
- Tighten the cover - see Figure 186 **point 2**

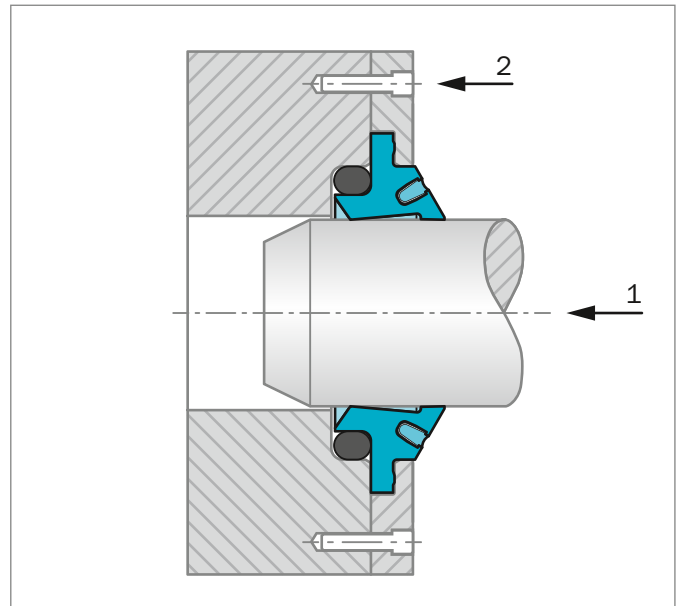

Figure 186: Installation and calibration of the Turcon® Excluder® S by the rod or a calibration mandrel

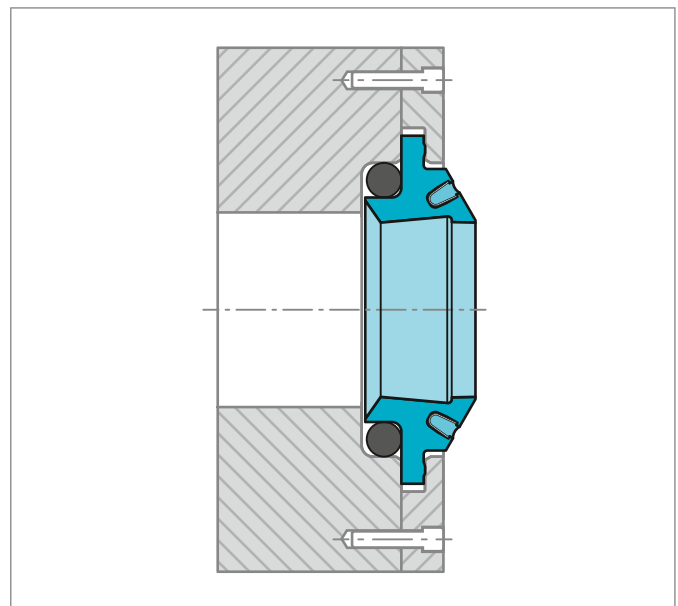

Figure 187: Turcon® Excluder® S installed in split groove



## RECOMMENDED MATERIALS

The following material combination has proven effective for most applications:

### Excluder® S in Turcon® M12

All round material for hydraulic applications with reciprocating, short stroke or helical movements in mineral oils, phosphate ester, bio-oils or fluids having less satisfactory lubricating properties:

O-Ring:	NBR 70 Shore A	N
	FKM 70 Shore A	V
	EPDM 70 Shore A	E
	(depending on medium and temperature)	

Set code: M12N, M12V or M12E

### Excluder® S in Turcon® T46

For medium to heavy duty applications with reciprocating movements in mineral oils and other media with good lubrication:

O-Ring:	NBR 70 Shore A	N
	FKM 70 Shore A	V
	(depending on medium and temperature)	

Set code: T46N or T46V

### Excluder® S in Zurcon® Z80/Z82

For lubricating and non-lubricating fluids including water, air and gases:

O-Ring:	NBR 70 Shore A	N
	EPDM 70 Shore A	E
	(depending on medium and temperature)	

Set code: Z80N or Z80E

Other available material combinations are listed in Table 176.

For specific applications, all Turcon® materials are available.



**Table 176: Turcon® and Zurcon® Materials for Excluder® S**

Material, Applications, Properties	Code	O-Ring Material Shore A	Code	O-Ring Operating Temp. * °C	Mating Surface Material	Speed max. m/s
<b>Turcon® M12</b> First material choice for linear motion Overall improved properties For new constructions and updating For all commonly applied hydraulic fluids including fluids with low lubrication performance Lowest friction and best sliding properties Lowest wear on Excluder® Improved absorption of abrasive contaminants Low wear or abrasion of counter surface BAM tested Mineral fiber and Additives filled Color: Dark gray	M12	NBR 70	N	-30 to +100	Steel	15
		NBR 70 Low temp.	T	-45 to +80	Steel, hardened Steel, chrome-plated (rod) Cast iron	
		FKM 70	V	-10 to +200	Stainless steel Titanium	
<b>Turcon® T40</b> For lubricating and non-lubricating fluids Linear and rotary motion High frequency and short strokes Water hydraulics Surface texture not suitable for gas sealing Carbon fiber filled Color: Gray	T40	NBR 70	N	-30 to +100	Steel	15
		NBR 70 Low temp.	T	-45 to +80	Steel, chrome-plated (rod) Cast iron	
		FKM 70	V	-10 to +200	Stainless steel	
		EPDM 70	E**	-45 to +145	Aluminum Bronze Alloys	
<b>Turcon® T46</b> For lubricated hydraulics in linear motion High compressive strength High extrusion resistance Very good sliding and wear properties BAM tested Bronze filled Color: Light to dark brown, which may have variations in shading.	T46	NBR 70	N	-30 to +100	Steel (tubes)	15
		NBR 70 Low temp.	T	-45 to +80	Steel, hardened Steel, chrome-plated (rod)	
		FKM 70	V	-10 to +200	Cast iron	
<b>Zurcon® Z53***</b> For mineral oil based fluids Linear and slowly turning movement Very high abrasion and extrusion resistance For counter surface with rougher surface finish More difficult to install Limited chemical resistance Max. working temperature +110 °C Cast polyurethane Color: Yellow to light-brown	Z53	NBR 70	N	-30 to +100	Steel	1
		NBR 70 Low temp.	T	-45 to +80	Steel, hardened Steel chrome plated (rod) Cast iron Ceramic coating Stainless steel	

Table continues on next page





Material, Applications, Properties	Code	O-Ring Material Shore A	Code	O-Ring Operating Temp.* °C	Mating Surface Material	Speed max. m/s
<b>Zurcon® Z54***</b> For mineral oil based fluids Linear and slowly turning movements High abrasion resistance For counter surface with rougher surface finishes Good extrusion resistance Limited chemical resistance Max. working temperature +110 °C Cast polyurethane Color: Turquoise	Z54	NBR 70	N	-30 to +100	Steel	1
		NBR 70 Low temp.	T	-45 to +80	Steel, hardened Steel, chrome-plated (rod) Cast iron Stainless steel Aluminum Bronze Alloys Ceramic coating	
<b>Zurcon® Z80</b> For lubricating and non-lubricating fluids Water based fluids, air and gases Dry air pneumatics Linear and slowly turning movements High abrasion and extrusion resistance For service in abrasive conditions and media with particles Good chemical resistance Limited temperature capability (-60 to +80 °C) Not resistant to UV-light (sunlight), use Z82 instead UHMWPE (Ultra High Molecular Weight Polyethylene) Color: White to off white	Z80	NBR 70	N	-30 to (+100)	Steel	2
		NBR 70 Low temp.	T	-45 to +80	Steel, chrome-plated (rod) Stainless steel	
		EPDM 70	E**	-45 to (+145)	Aluminum Bronze Ceramic coating	
<b>Zurcon® Z82</b> Same as Z80 but resistant to UV-light (sunlight) UHMWPE (Ultra High Molecular Weight Polyethylene) Color: Black	Z82	NBR 70	N	-30 to (+100)	Steel	2
		NBR 70 Low temp.	T	-45 to +80	Steel, chrome-plated (rod) Stainless steel	
		EPDM 70	E**	-45 to (+145)	Aluminum Bronze Ceramic coating	

\* The O-Ring Operation Temperature is only valid in mineral hydraulic oil, except EPDM.

\*\* Material not suitable for mineral oils.

\*\*\* Max. diameter 2,200 mm

BAM: Tested by "Bundesanstalt Materialprüfung, Germany".

Highlighted materials are recommended.





Table 178: Installation Dimensions / TSS Part No.

Rod Dia.	Groove Dia.	Groove Width	TSS Part No.	O-Ring Size	Rod Dia.	Groove Dia.	Groove Width	TSS Part No.	O-Ring Size
$d_N$ f8/h9	$D_3$ H10	$L_3$ +0.2			$d_N$ f8/h9	$D_3$ H10	$L_3$ +0.2		
<b>16.0</b>	<b>28.0</b>	<b>2.20</b>	<a href="#">WES000160</a>	<b>19.00 x 1.80</b>	440.0	468.0	6.30	<a href="#">WES304400</a>	430.66 x 5.33
<b>18.0</b>	<b>30.0</b>	<b>2.20</b>	<a href="#">WES000180</a>	<b>21.95 x 1.78</b>	450.0	478.0	6.30	<a href="#">WES304500</a>	456.06 x 5.33
<b>20.0</b>	<b>32.0</b>	<b>2.20</b>	<a href="#">WES000200</a>	<b>23.52 x 1.78</b>	480.0	508.0	6.30	<a href="#">WES304800</a>	481.38 x 5.33
<b>22.0</b>	<b>34.0</b>	<b>2.20</b>	<a href="#">WES000220</a>	<b>25.12 x 1.78</b>	500.0	528.0	6.30	<a href="#">WES305000</a>	506.78 x 5.33
<b>25.0</b>	<b>37.0</b>	<b>2.20</b>	<a href="#">WES000250</a>	<b>28.30 x 1.78</b>	550.0	578.0	6.30	<a href="#">WES305500</a>	532.18 x 5.33
<b>28.0</b>	<b>40.0</b>	<b>2.20</b>	<a href="#">WES000280</a>	<b>31.47 x 1.78</b>	600.0	628.0	6.30	<a href="#">WES306000</a>	582.68 x 5.33
30.0	42.0	2.20	<a href="#">WES000300</a>	33.05 x 1.78	650.0	678.0	6.30	<a href="#">WES306500</a>	633.48 x 5.33
<b>32.0</b>	<b>44.0</b>	<b>2.20</b>	<a href="#">WES000320</a>	<b>34.65 x 1.78</b>	680.0	708.0	6.30	<a href="#">WES306800</a>	658.88 x 5.33
<b>36.0</b>	<b>48.0</b>	<b>2.20</b>	<a href="#">WES000360</a>	<b>37.82 x 1.78</b>	700.0	728.0	6.30	<a href="#">WES307000</a>	658.88 x 5.33
<b>40.0</b>	<b>52.0</b>	<b>2.20</b>	<a href="#">WES000400</a>	<b>44.17 x 1.78</b>	750.0	778.0	6.30	<a href="#">WES307500</a>	658.88 x 5.33
<b>45.0</b>	<b>57.0</b>	<b>2.20</b>	<a href="#">WES000450</a>	<b>47.35 x 1.78</b>	800.0	833.0	8.25	<a href="#">WES408000</a>	809 x 7.00
<b>50.0</b>	<b>68.7</b>	<b>4.20</b>	<a href="#">WES200500</a>	<b>53.57 x 3.53</b>	850.0	883.0	8.25	<a href="#">WES408500</a>	859 x 7.00
<b>56.0</b>	<b>74.7</b>	<b>4.20</b>	<a href="#">WES200560</a>	<b>59.92 x 3.53</b>	900.0	933.0	8.25	<a href="#">WES409000</a>	909 x 7.00
<b>63.0</b>	<b>81.7</b>	<b>4.20</b>	<a href="#">WES200630</a>	<b>66.27 x 3.53</b>	950.0	983.0	8.25	<a href="#">WES409500</a>	959 x 7.00
<b>70.0</b>	<b>88.7</b>	<b>4.20</b>	<a href="#">WES200700</a>	<b>72.62 x 3.53</b>	1,000.0	1,033.0	8.25	<a href="#">WES4X1000</a>	1,009 x 7.00
<b>80.0</b>	<b>98.7</b>	<b>4.20</b>	<a href="#">WES200800</a>	<b>82.14 x 3.53</b>	1,200.0	1,233.0	8.25	<a href="#">WES4X1200</a>	1,209 x 7.00
<b>90.0</b>	<b>108.7</b>	<b>4.20</b>	<a href="#">WES200900</a>	<b>94.84 x 3.53</b>	1,500.0	1,533.0	8.25	<a href="#">WES4X1500</a>	1,509 x 7.00
<b>100.0</b>	<b>118.7</b>	<b>4.20</b>	<a href="#">WES201000</a>	<b>104.37 x 3.53</b>	1,800.0	1,833.0	8.25	<a href="#">WES4X1800</a>	1,809 x 7.00
<b>110.0</b>	<b>128.7</b>	<b>4.20</b>	<a href="#">WES201100</a>	<b>113.89 x 3.53</b>	2,000.0	2,033.0	8.25	<a href="#">WES4X2000</a>	2,009 x 7.00
120.0	138.7	4.20	<a href="#">WES201200</a>	123.42 x 3.53	2,200.0	2,233.0	8.25	<a href="#">WES4X2200</a>	2,209 x 7.00
<b>125.0</b>	<b>143.7</b>	<b>4.20</b>	<a href="#">WES201250</a>	<b>129.77 x 3.53</b>	2,600.0	2,633.0	8.25	<a href="#">WES4X2600</a>	2,609 x 7.00
130.0	148.7	4.20	<a href="#">WES201300</a>	132.94 x 3.53					
<b>140.0</b>	<b>158.7</b>	<b>4.20</b>	<a href="#">WES201400</a>	<b>142.47 x 3.53</b>					
150.0	168.7	4.20	<a href="#">WES201500</a>	151.99 x 3.53					
<b>160.0</b>	<b>178.7</b>	<b>4.20</b>	<a href="#">WES201600</a>	<b>164.69 x 3.53</b>					
170.0	188.7	4.20	<a href="#">WES201700</a>	171.04 x 3.53					
<b>180.0</b>	<b>198.7</b>	<b>4.20</b>	<a href="#">WES201800</a>	<b>183.74 x 3.53</b>					
190.0	208.7	4.20	<a href="#">WES201900</a>	190.09 x 3.53					
<b>200.0</b>	<b>218.7</b>	<b>4.20</b>	<a href="#">WES202000</a>	<b>202.79 x 3.53</b>					
210.0	228.7	4.20	<a href="#">WES202100</a>	209.14 x 3.53					
<b>220.0</b>	<b>238.7</b>	<b>4.20</b>	<a href="#">WES202200</a>	<b>221.84 x 3.53</b>					
230.0	248.7	4.20	<a href="#">WES202300</a>	234.54 x 3.53					
240.0	258.7	4.20	<a href="#">WES202400</a>	240.89 x 3.53					
<b>250.0</b>	<b>268.7</b>	<b>4.20</b>	<a href="#">WES202500</a>	<b>253.59 x 3.53</b>					
<b>280.0</b>	<b>298.7</b>	<b>4.20</b>	<a href="#">WES202800</a>	<b>278.99 x 3.53</b>					
300.0	318.7	4.20	<a href="#">WES203000</a>	304.39 x 3.53					
<b>320.0</b>	<b>338.7</b>	<b>4.20</b>	<a href="#">WES203200</a>	<b>304.39 x 3.53</b>					
350.0	378.0	6.30	<a href="#">WES303500</a>	354.97 x 5.33					
<b>360.0</b>	<b>388.0</b>	<b>6.30</b>	<a href="#">WES303600</a>	<b>365.00 x 5.30</b>					
380.0	408.0	6.30	<a href="#">WES303800</a>	380.37 x 5.33					
400.0	428.0	6.30	<a href="#">WES304000</a>	405.26 x 5.33					
420.0	448.0	6.30	<a href="#">WES304200</a>	405.26 x 5.33					

The rod diameters in **bold** type comply with the recommendations of ISO 3320



## Optional Designs

### Turcon® Excluder® SN

Optional, Turcon® Excluder® SN - Figure 189 the internal sealing lip has axial notch for applications where pressure trapping behind Excluder® S exceeds the allowed 1.5 MPa and a drain line not applicable.

The axial notch will lead the pressure to the scraping lip, which is lifted and relieving the pressure. This version is only delivered on TSS Standard Part Number with V-Spring Excluder® lip activation.

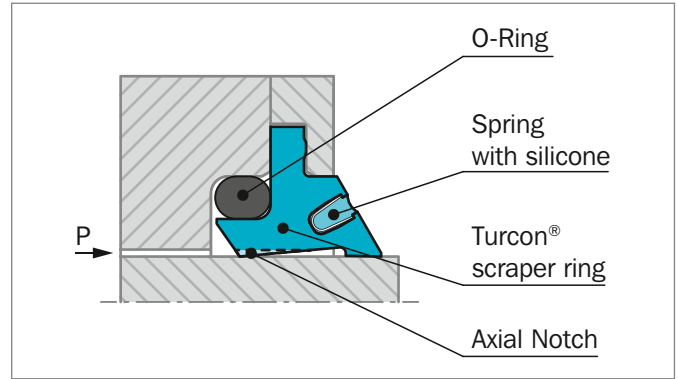

Figure 189: Optional Turcon® Excluder® SN where internal sealing lip has axial notch.

### ORDERING EXAMPLE

Optional Excluder® SN with V-Spring and Notch on internal sealing lip, complete with O-Ring, standard application:

<b>Series:</b>	WES3N from Table 177
<b>Rod Diameter:</b>	$d_N = 350.0$ mm
<b>TSS Part No.:</b>	WES3N3500 from Table 178

Select the material from Table 176. The corresponding code numbers are appended to the TSS Part No. Together these form the TSS Article Number. The TSS Article No. for all intermediate sizes can be determined by following the example:

<b>TSS Article No.</b>	<b>WES3</b>	<b>N</b>	<b>3500</b>	<b>-</b>	<b>M12</b>	<b>N</b>
Series No.	_____	_____	_____	_____	_____	_____
Type (Standard)	_____	_____	_____	_____	_____	_____
Rod Diameter x 10*	_____	_____	_____	_____	_____	_____
Quality Index (Standard)	_____	_____	_____	_____	_____	_____
Material Code (Scraper)	_____	_____	_____	_____	_____	_____
Material Code (O-Ring)	_____	_____	_____	_____	_____	_____

\* For diameters  $d_N \geq 1,000$  mm WES\_N is available on TSS Special Part No.



### Turcon® Excluder® SR

Optional Turcon® Excluder® SR - Figure 190 - with 2 O-Rings as elastic energizing elements.

The V-Spring is exchanged with an O-Ring for applications with less demanding service and situations where conditions or regulations eliminate applying metal V-Spring with silicone.

When Installing Excluder® SR with O-Ring scraper lip activation the O-Ring is mounted into the lip before the Excluder® Ring is placed in the groove.

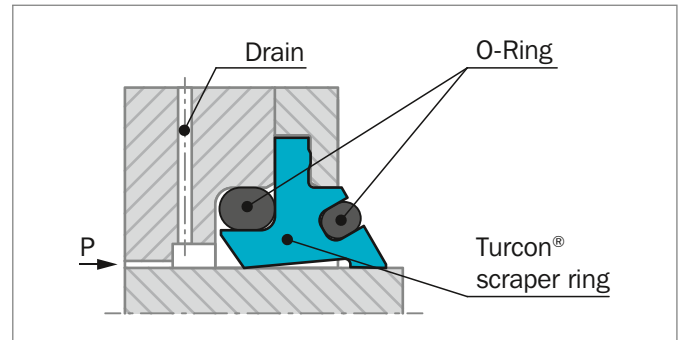

Figure 190: Optional Turcon® Excluder® SR with O-Ring activated Excluder® lip

### ORDERING EXAMPLE

Turcon® Excluder® SR complete with O-Rings, standard application:

<b>Series:</b>	WES3R from Table 177
<b>Rod Diameter:</b>	$d_N = 350.0$ mm
<b>TSS Part No.:</b>	WES3R3500 from Table 178

Select the material from Table 176. The corresponding code numbers are appended to the TSS Part No. Together these form the TSS Article Number. The TSS Article No. for all intermediate sizes can be determined by following the example:

<b>TSS Article No.</b>	<b>WES3</b>	<b>R</b>	<b>3500</b>	<b>-</b>	<b>M12</b>	<b>N</b>
Series No.	_____	_____	_____	_____	_____	_____
Type (Standard)	_____	_____	_____	_____	_____	_____
Rod Diameter x 10*	_____	_____	_____	_____	_____	_____
Quality Index (Standard)	_____	_____	_____	_____	_____	_____
Material Code (Scraper)	_____	_____	_____	_____	_____	_____
Material Code (O-Ring)	_____	_____	_____	_____	_____	_____

\* For diameters  $d_N \geq 1,000$  mm WES\_R is available on TSS Special Part No.

---

! This page is intentionally left blank.

# Turcon® Excluder® 1 and Excluder® 113



---

Double-acting

---

Rubber-energized Double-acting Scraper

**Material:**

Turcon®, Zurcon® and Elastomer

---









## Turcon® Excluder® 1



### Description

Turcon® Excluder® 1 is the classic single acting scraper both for rough, delicate, hot or cold environments. It consists of two components, a scraper ring and a flexible elastomer O-Ring which ensures a tight contact with surface to be scraped. The O-Ring also functions as static seal between the opposite side of the scraper ring and the groove bottom.

### APPLICATIONS

Excluder® 1 can be installed in a variety of rod sealing systems with linear movements.

A single acting scraper requires a very tight sealing system for minimising the fluid film, which will pass the scraper as leakage, and to prevent pressure activation, which can disturb the scraping function.

Produced in hard Turcon® or Zurcon® materials, the robust Excluder® 1 is able to scrape off difficult and persistent impurities such as dust, dirt, solid particles, ice, etc.

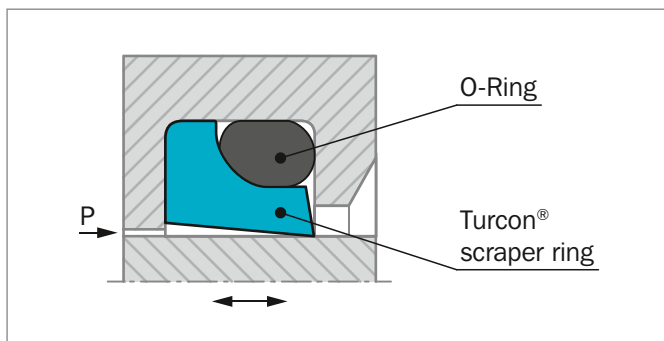

Figure 191: Turcon® Excluder® 1 an all-round single acting scraper

### ADVANTAGES

- Simple compact groove requirement, same as Turcon® Excluder® 2
- Excellent scraping performance
- Excellent wear resistant
- Compact robust design
- Compensates for deflection of the piston rod
- Low friction
- No stick-slip effect

- No vulcanising to counter surface
- High and low temperature capability
- Very high resistance to hydraulic media
- Available in all sizes from 6 mm to 999 mm. Sizes above 1,000 mm are available on TSS Special Part Number
- ISO 6195 Type D housing dimension up to diameter 63 mm

### OPERATING CONDITIONS

<b>Speed linear:</b>	Max. 15 m/s Turcon® materials
	Max. 5 m/s Zurcon® Z80 materials
	Max. 2 m/s Zurcon® Z53/Z54 materials

<b>Temperature:</b>	-45 °C to + 200 °C (Turcon® )
	-45 °C to + 80 °C (Zurcon® Z80)
	-45 °C to + 110 °C (Zurcon® Z53/Z54) depending on O-Ring material

<b>Media:</b>	Mineral oil-based hydraulic fluids, flame retardant hydraulic fluids, environmentally friendly hydraulic fluids (bio-oils), phosphate ester, water, air and others, depending on scraper ring and O-Ring material compatibility.
---------------	--

### IMPORTANT NOTE

The above data are maximum values and cannot be used at the same time, e.g. the maximum operating speed depends on material type, environment, temperature and media.

### INSTALLATION INSTRUCTIONS

Excluder® 1 scraper can be installed in split and closed grooves. Installation in closed grooves is dependent on the rod diameter, profile cross-section of the scraper and on the cord cross-section of the corresponding O-Ring, see Table 179.

**Table 179: Installation in Closed Grooves**

Turcon® Excluder® 1 Series No.	Rod Diameter $d_N$ mm	O-Ring Cross Section $d_2$ mm
WEM3, WEL5	> 30	1.78
WEM3, WEL5, WEH1	> 30	2.62
WEM3, WEL5, WEH1	> 30	3.53
WEM3, WEL5, WEH1	> 40	5.33
WEM3, WEL5, WEH1	> 110	7.00
WEM3, WEH1	> 140	8.40

- 1) The O-Ring is installed in the groove.
- 2) The Excluder® ring is compressed into a kidney-shape and placed in the groove, see Figure 192.

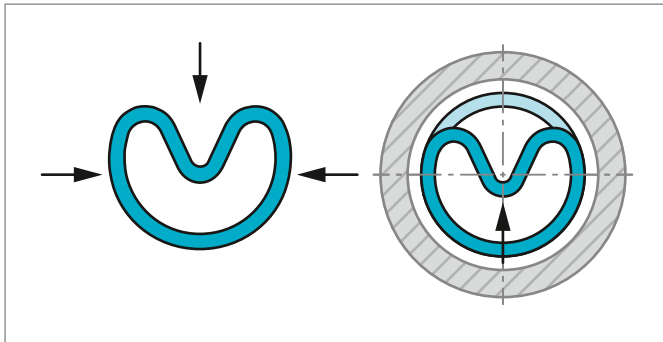

Figure 192: Place the Excluder® in compressed form into the groove behind the O-Ring and push Excluder® ring in the direction of the arrow

**RECOMMENDED MATERIALS**

The following material combinations have proven effective for hydraulic applications:

**Turcon® Excluder® 1 in Turcon® M12**

All round material for light to medium hydraulic applications linear, short stroke or helical movements in mineral oils, flame retardant hydraulic fluids, phosphate ester, bio-oils or fluids having low lubricating properties:

O-Ring: NBR 70 Shore A N  
FKM 70 Shore A V

Set code: M12N or M12V

**Turcon® Excluder® 1 in Turcon® T46**

For medium to heavy applications with linear movements in mineral oils and other media with good lubrication:

O-Ring: NBR 70 Shore A N  
FKM 70 Shore A V

Set code: T46N or T46V

For specific applications, all Turcon® materials are available. Other material combinations are listed in Table 180.

**Table 180: Turcon® and Zurcon® Materials for Excluder® 1 and 113**

Material, Applications, Properties	Code	O-Ring Material Shore A	Code	O-Ring Operating Temp. * °C	Mating Surface Material	Speed max. m/s
<b>Turcon® M12</b> First material choice for linear motion Overall improved properties For new constructions and updating For all commonly applied hydraulic fluids including fluids with low lubrication performance Lowest friction and best sliding properties Lowest wear on seals Improved absorption of abrasive contaminants Low wear or abrasion of counter surface BAM tested Mineral fiber and Additives filled Color: Dark gray	M12	NBR 70	N	-30 to +100	Steel	15
		NBR 70 Low temp.	T	-45 to +80	Steel, hardened Steel, chrome plated (rod)	
		FKM 70	V	-10 to +200	Steel plated (rod) Cast iron Stainless steel Titanium	
<b>Turcon® T40</b> For lubricating and non-lubricating fluids High frequency and short strokes Water hydraulics Surface texture is not suitable for gas sealing Carbon fiber filled Color: Gray.	T40	NBR 70	N	-30 to +100	Steel	15
		NBR 70 Low temp.	T	-45 to +80	Steel, chrome plated (rod) Cast iron	
		FKM 70	V	-10 to +200	Stainless steel	
		EPDM 70	E**	-45 to +145	Aluminum	
<b>Turcon® T46</b> For lubricated hydraulics in linear motion High compressive strength High extrusion resistance Very good sliding and wear properties BAM tested Bronze filled Color: Light to dark brown, which may have variations in shading.	T46	NBR 70	N	-30 to +100	Steel, hardened	15
		NBR 70 Low temp.	T	-45 to +80	Steel, chrome plated (rod) Cast iron	
		FKM 70	V	-10 to +200		
<b>Zurcon® Z53***</b> For mineral oil based fluids Very high abrasion and extrusion resistance For counter surface with rougher surface finishes More difficult to install Limited chemical resistance Max. working temperature +110 °C Cast polyurethane Color: Yellow to light-brown	Z53	NBR 70	N	-30 to +100	Steel	1
		NBR 70 Low temp.	T	-45 to +80	Steel, hardened Steel chrome plated (rod) Cast iron Ceramic coating Stainless steel	

Table continues on next page



Material, Applications, Properties	Code	O-Ring Material Shore A	Code	O-Ring Operating Temp.* °C	Mating Surface Material	Speed max. m/s
<b>Zurcon® Z54***</b> For mineral oil based fluids Linear and slowly turning movements High abrasion resistance For counter surface with rougher surface finishes Good extrusion resistance Limited chemical resistance Max. working temperature +110 °C Cast polyurethane Color: Turquoise	Z54	NBR 70	N	-30 to +100	Steel	1
		NBR 70 Low temp.	T	-45 to +80	Steel, hardened Steel, chrome plated (rod) Cast iron Stainless steel Aluminum Ceramic coating	
<b>Zurcon® Z80</b> For lubricating and non-lubricating fluids Water based fluids, air and gases Dry air pneumatics High abrasion and extrusion resistance For service in abrasive conditions and media with particles Good chemical resistance Limited temperature capability (-60 to +80 °C) UHMWPE (Ultra High Molecular Weight Polyethylene)	Z80	NBR 70	N	-30 to (+100)	Steel	5
		NBR 70 Low temp.	T	-45 to +80	Steel, chrome plated (rod) Stainless steel	
		EPDM 70	E**	-45 to (+145)	Aluminum Ceramic coating	

\* The O-Ring Operation Temperature is only valid in mineral hydraulic oil, except EPDM.

\*\* Material not suitable for mineral oils.

\*\*\* Max. diameter 2,200 mm

BAM: Tested by "Bundesanstalt Materialprüfung, Germany".

  Highlighted materials are recommended.



## Installation Recommendation

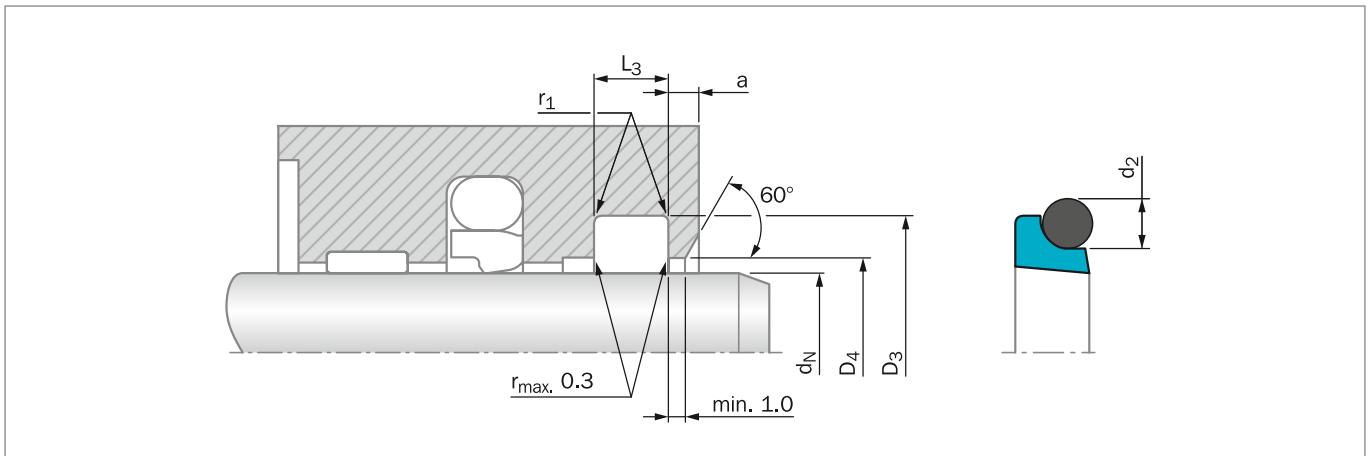

Figure 193: Installation Drawing

**Table 181: Installation Dimensions – Standard Recommendations**

Rod Diameter $d_N$ f8/h9			Groove Diameter	Groove Width	Bore Diameter	Step Width	Radius	O-Ring Cross Section
Serie No. WEM3 Standard Application	Serie No. WEL5 Light Application	Serie No. WEH1 Heavy Duty Application	$D_3$ H9	$L_3$ +0.2	$D_4$ H11	$a_{min}$	$r_1$ max	$d_2$
6 - 11.9	12 - 64.9	-	$d_N + 4.8$	3.7	$d_N + 1.5$	2.0	0.4	1.78
12 - 64.9	65 - 250.9	6 - 11.9	$d_N + 6.8$	5.0	$d_N + 1.5$	2.0	0.7	2.62
65 - 250.9	251 - 420.9	12 - 64.9	$d_N + 8.8$	6.0	$d_N + 1.5$	3.0	1.0	3.53
251 - 420.9	421 - 650.9	65 - 250.9	$d_N + 12.2$	8.4	$d_N + 2.0$	4.0	1.2	5.33
421 - 650.9	651 - 999.9	251 - 420.9	$d_N + 16.0$	11.0	$d_N + 2.0$	4.0	1.5	7.00
651 - 999.9		421 - 650.9	$d_N + 20.0$	14.0	$d_N + 2.5$	5.0	2.0	8.40

Sizes from  $d_N$  1,000.0 mm to  $d_N$  2,600.0 mm are available on TSS special part number

### ORDERING EXAMPLE

Turcon® Excluder® 1 complete with O-Ring, standard application:

**Series:** WEM3 from Table 181

**Rod Diameter:**  $d_N = 50.0$  mm

**TSS Part No.:** WEM300500 from Table 182

Select the material from Table 180. The corresponding code numbers are appended to the TSS Part No. Together these form the TSS Article Number. The TSS Article No. for all intermediate sizes can be determined by following the example:

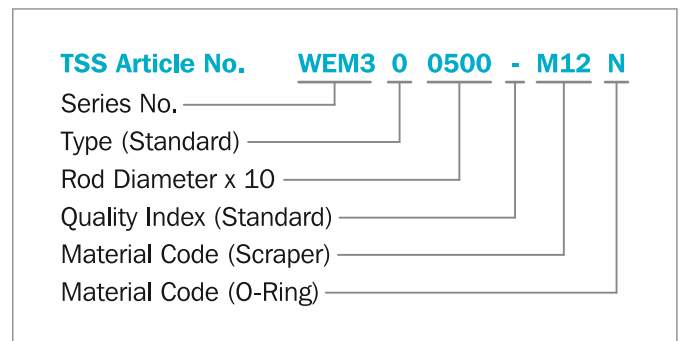



**Table 182: Installation Dimensions / TSS Part Numbers**

Rod Dia.	Groove Dia.	Groove Width	TSS Part No.	O-Ring Size	Rod Dia.	Groove Dia.	Groove Width	TSS Part No.	O-Ring Size
d <sub>N</sub> f8/h9	D <sub>3</sub> H9	L <sub>3</sub> +0.2			d <sub>N</sub> f8/h9	D <sub>3</sub> H9	L <sub>3</sub> +0.2		
6.0*	10.8	3.7	<a href="#">WEM300060</a>	7.65 x 1.78	225.0	233.8	6.0	<a href="#">WEM302250</a>	228.19 x 3.53
8.0*	12.8	3.7	<a href="#">WEM300080</a>	9.50 x 1.80	250.0	258.8	6.0	<a href="#">WEM302500</a>	253.59 x 3.53
10.0*	14.8	3.7	<a href="#">WEM300100</a>	11.80 x 1.80	275.0	287.2	8.4	<a href="#">WEM302750</a>	278.77 x 5.33
12.0*	18.8	5.0	<a href="#">WEM300120</a>	13.94 x 2.62	300.0	312.2	8.4	<a href="#">WEM303000</a>	304.17 x 5.33
14.0*	20.8	5.0	<a href="#">WEM300140</a>	15.54 x 2.62	320.0	332.2	8.4	<a href="#">WEM303200</a>	304.17 x 5.33
16.0*	22.8	5.0	<a href="#">WEM300160</a>	18.00 x 2.65	380.0	392.2	8.4	<a href="#">WEM303800</a>	380.37 x 5.33
18.0*	24.8	5.0	<a href="#">WEM300180</a>	20.29 x 2.62	400.0	412.2	8.4	<a href="#">WEM304000</a>	405.26 x 5.33
19.0	25.8	5.0	<a href="#">WEM300190</a>	20.29 x 2.62	450.0	466.0	11.0	<a href="#">WEM304500</a>	443.36 x 7.00
20.0*	26.8	5.0	<a href="#">WEM300200</a>	21.89 x 2.62	480.0	496.0	11.0	<a href="#">WEM304800</a>	481.38 x 7.00
22.0*	28.8	5.0	<a href="#">WEM300220</a>	23.47 x 2.62	500.0	516.0	11.0	<a href="#">WEM305000</a>	494.16 x 7.00
25.0*	31.8	5.0	<a href="#">WEM300250</a>	26.64 x 2.62	550.0	566.0	11.0	<a href="#">WEM305500</a>	557.66 x 7.00
28.0*	34.8	5.0	<a href="#">WEM300280</a>	29.82 x 2.62	600.0	616.0	11.0	<a href="#">WEM306000</a>	608.08 x 7.00
30.0	36.8	5.0	<a href="#">WEM300300</a>	31.42 x 2.62	640.0	656.0	11.0	<a href="#">WEM306400</a>	633.48 x 7.00
32.0*	38.8	5.0	<a href="#">WEM300320</a>	34.59 x 2.62	680.0	700.0	14.0	<a href="#">WEM306800</a>	685 x 8.40
33.0	39.8	5.0	<a href="#">WEM300330</a>	34.59 x 2.62	700.0	720.0	14.0	<a href="#">WEM307000</a>	705 x 8.40
34.0	40.8	5.0	<a href="#">WEM300340</a>	36.17 x 2.62	750.0	770.0	14.0	<a href="#">WEM307500</a>	755 x 8.40
35.0	41.8	5.0	<a href="#">WEM300350</a>	36.17 x 2.62	800.0	820.0	14.0	<a href="#">WEM308000</a>	805 x 8.40
36.0*	42.8	5.0	<a href="#">WEM300360</a>	37.77 x 2.62	850.0	870.0	14.0	<a href="#">WEM308500</a>	855 x 8.40
40.0*	46.8	5.0	<a href="#">WEM300400</a>	42.52 x 2.62	900.0	920.0	14.0	<a href="#">WEM309000</a>	905 x 8.40
45.0*	51.8	5.0	<a href="#">WEM300450</a>	47.29 x 2.62	950.0	970.0	14.0	<a href="#">WEM309500</a>	955 x 8.40
48.0	54.8	5.0	<a href="#">WEM300480</a>	50.47 x 2.62					
50.0*	56.8	5.0	<a href="#">WEM300500</a>	52.07 x 2.62					
56.0*	62.8	5.0	<a href="#">WEM300560</a>	58.42 x 2.62					
60.0	66.8	5.0	<a href="#">WEM300600</a>	61.60 x 2.62					
63.0*	69.8	5.0	<a href="#">WEM300630</a>	64.77 x 2.62					
65.0	73.8	6.0	<a href="#">WEM300650</a>	66.27 x 3.53					
70.0	78.8	6.0	<a href="#">WEM300700</a>	72.62 x 3.53					
75.0	83.8	6.0	<a href="#">WEM300750</a>	75.79 x 3.53					
80.0	88.8	6.0	<a href="#">WEM300800</a>	82.14 x 3.53					
85.0	93.8	6.0	<a href="#">WEM300850</a>	85.32 x 3.53					
90.0	98.8	6.0	<a href="#">WEM300900</a>	91.67 x 3.53					
100.0	108.8	6.0	<a href="#">WEM301000</a>	101.19 x 3.53					
110.0	118.8	6.0	<a href="#">WEM301100</a>	110.72 x 3.53					
120.0	128.8	6.0	<a href="#">WEM301200</a>	120.24 x 3.53					
130.0	138.8	6.0	<a href="#">WEM301300</a>	132.94 x 3.53					
140.0	148.8	6.0	<a href="#">WEM301400</a>	142.47 x 3.53					
150.0	158.8	6.0	<a href="#">WEM301500</a>	151.99 x 3.53					
160.0	168.8	6.0	<a href="#">WEM301600</a>	158.34 x 3.53					
180.0	188.8	6.0	<a href="#">WEM301800</a>	177.39 x 3.53					
200.0	208.8	6.0	<a href="#">WEM302000</a>	202.79 x 3.53					

\* Installation in grooves according to ISO 6195 Type D



## Turcon® Excluder® 113

### Description

If Turcon® Excluder® 1 has been deformed or tilted by pressure activation, and acted as a seal, the pressure might have extruded and damaged the scraper lip.

To prevent this a one-way pressure relief version can be utilised where the pressure in all circumstances is channelled to a circumferential groove in Turcon® Excluder® 113 below the elastomers activation element. Should a high pressure appear, the scraping lip will shortly be lifted and the pressure released. Excluder® 113 is also applicable where the choice of seals would involve a risk of hydrodynamic pressure build-up between a seal and a double lip Excluder® .

Only available on TSS Standard Part No. in WEM3 series in all sizes from 6 mm to 999 mm. Sizes above 1,000 mm are available on TSS Special Part Number.

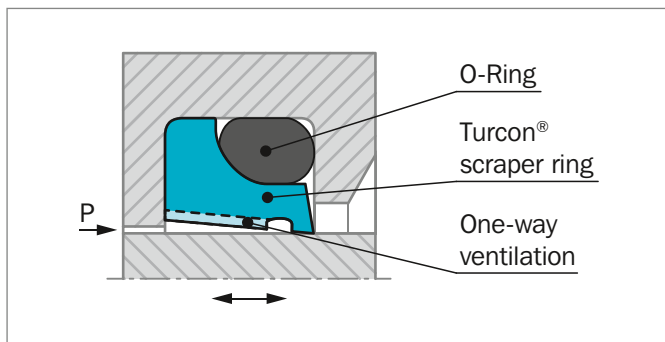

Figure 194: Turcon® Excluder® 113 with built-in one-way pressure relief

### OPERATING CONDITIONS

Identical to Turcon® Excluder® 1 see page 531.

### INSTALLATION INSTRUCTIONS

Excluder® 113 scrapers can be installed in split and closed grooves.

Installation in closed grooves is dependent on the rod diameter, profile cross-section of the scraper and on the cord cross-section of the corresponding O-Ring, see Table 183.

**Table 183: Installation in Closed Grooves**

Turcon® Excluder® 113 Series No.	Rod Diameter $d_N$ mm	O-Ring Cross Section- $\emptyset$ $d_2$ mm
WEM3E	> 30	1.78
WEM3E	> 30	2.62
WEM3E	> 30	3.53
WEM3E	> 40	5.33
WEM3E	> 110	7.00
WEM3E	> 140	8.40

Installation procedure is identical to Turcon® Excluder® 1

### MATERIALS

Identical to Turcon® Excluder® 1, see Table 180.



## ■ Installation Recommendation

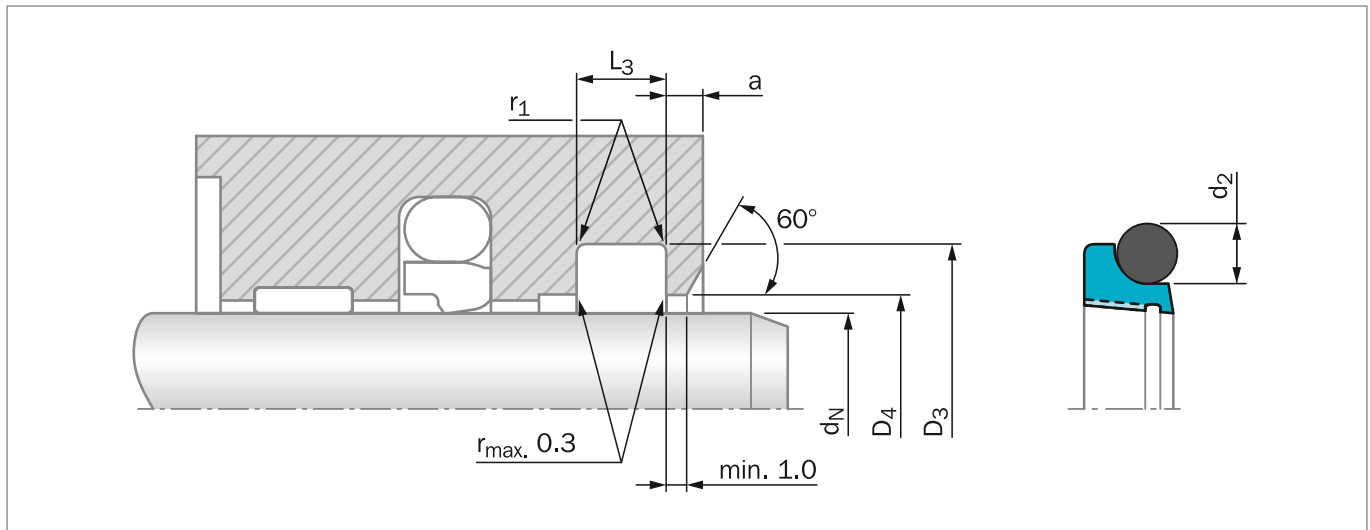

Figure 195: Installation Drawing

**Table 184: Installation Dimensions**

Series No.	Rod Diameter $d_N$ f8/h9	Groove Diameter	Groove Width	Bore Diameter	Step Width	Radius	O-Ring Cross Section
	Standard Application	$D_3$ H9	$L_3$ +0.2/-0.0	$D_4$ H11	$a_{min}$	$r_1$ max	$d_2$
WEM3E	6 – 11.9	$d_N + 4.8$	3.7	$d_N + 1.5$	2.0	0.4	1.78
WEM3E	12 – 64.9	$d_N + 6.8$	5.0	$d_N + 1.5$	2.0	0.7	2.62
WEM3E	65 – 250.9	$d_N + 8.8$	6.0	$d_N + 1.5$	3.0	1.0	3.53
WEM3E	251 – 420.9	$d_N + 12.2$	8.4	$d_N + 2.0$	4.0	1.2	5.33
WEM3E	421 – 650.9	$d_N + 16.0$	11.0	$d_N + 2.0$	4.0	1.5	7.00
WEM3E	651 – 999.9	$d_N + 20.0$	14.0	$d_N + 2.5$	5.0	2.0	8.40

Sizes from  $d_N$  1,000.0 mm to  $d_N$  2,600.0 mm are available on special part number.

### ORDERING EXAMPLE

Turcon® Excluder® 113 complete with O-Ring, standard application:

<b>Series:</b>	WEM3E from Table 184
<b>Rod Diameter:</b>	$d_N = 50.0$ mm
<b>TSS Part No.:</b>	WEM3E0500 from Table 182

Select the material from Table 180. The corresponding code numbers are appended to the TSS Part No. Together these form the TSS Article Number. The TSS Article No. for all intermediate sizes can be determined by following the example:

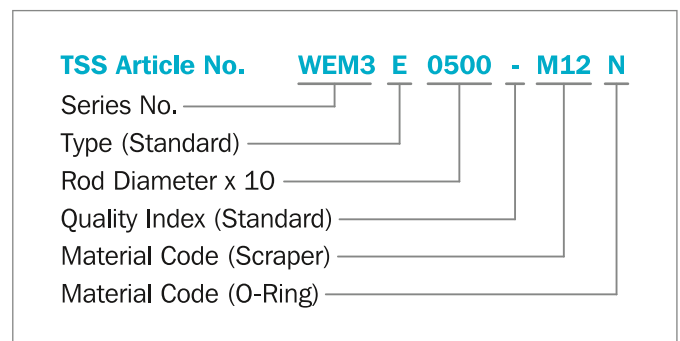



# Scraper DA17



---

Double-acting

---

**Material:**  
Rubber

---







## ■ Scraper DA17



### ■ Description

The scraper DA17 is a molded double-acting elastomer scraper. It has two geometrically different scraper lips.

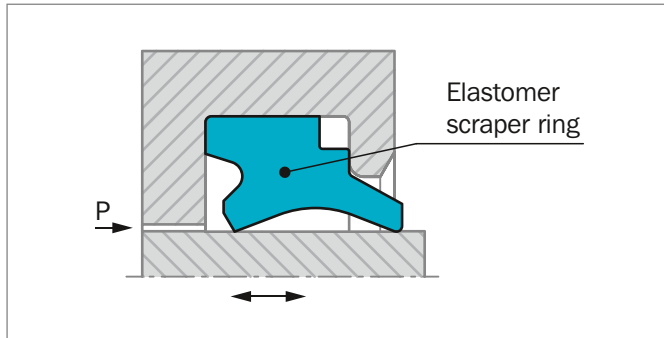

Figure 196: Scraper DA17

The scraper is preferably used for reciprocating piston rods and plunger pistons in hydraulic cylinders. It prevents the penetration of dirt into the system and on the medium side holds back the residual oil film from the extending piston rod.

The scraper is preferably used in conjunction with our rod seal Turcon® Stepseal®, i.e. seals with a hydrodynamic back-pumping function.

### ADVANTAGES

- Low friction
- Good scraping effect both inwards and outwards
- Simple, small installation groove
- Compact design
- Easy installation and removal without tools

### OPERATING CONDITIONS

<b>Speed:</b>	Up to 1 m/s
<b>Temperature:</b>	-25 °C to +100 °C
<b>Media:</b>	Mineral oil-based hydraulic fluids, flame retardant hydraulic fluids (HFA, HFB, HFC), water, air, etc.

### IMPORTANT NOTE

The above data are maximum values and cannot be used at the same time, e.g. the maximum operating speed depends on material type, pressure, temperature and gap value. Temperature range also depends on media.

### MATERIAL

Standard material: NBR 90 Shore A



## ■ Installation Recommendation

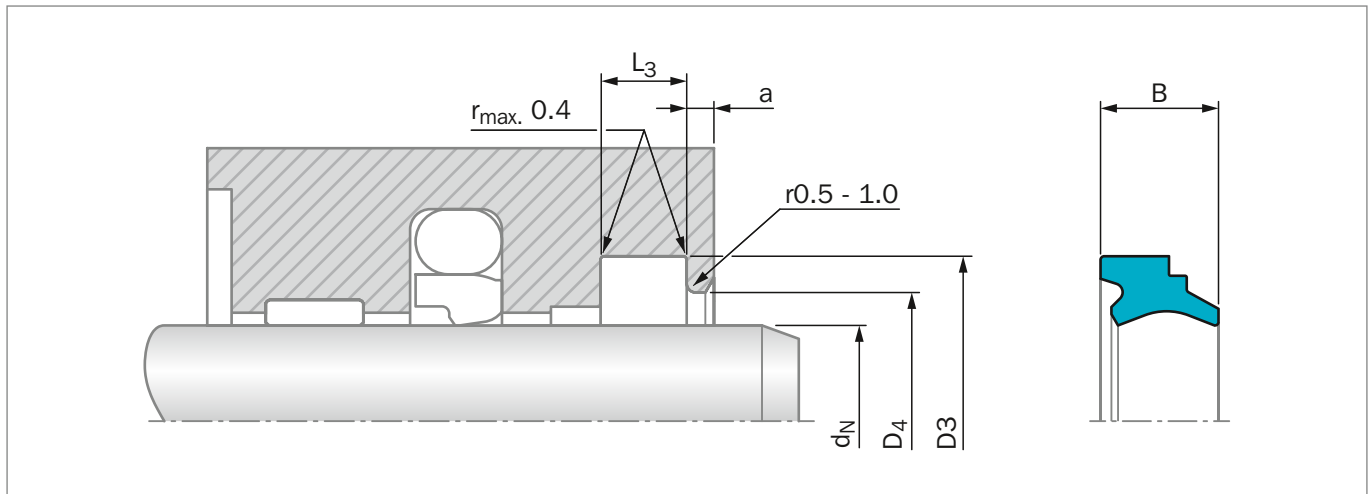

Figure 197: Installation Drawing

### ORDERING EXAMPLE

Scraper DA17

<b>Rod Diameter:</b>	$d_N = 50.0 \text{ mm}$
<b>TSS Part No.:</b>	WD1700500 from Table 185
<b>Material:</b>	Standard material NBR 90 Shore A, Code N9

<b>TSS Article No.</b>	<b>WD17 0 0500 - N9</b>
TSS Series No.	WD17
Type (Standard)	0
Rod Diameter x 10	0500
Quality Index	-
Material Code	N9

Table 185: Installation Dimensions / TSS Part No.

Rod Diameter	Groove Diameter	Groove Width	Bore Diameter	Step Width	Width	TSS Part No.
$d_N$	D3	$L_3$	D4	$a_{min}$	B	
f8/h9	H9	+0.2	H11			
<b>10.0</b>	<b>18.0</b>	<b>6.0</b>	<b>13.5</b>	<b>2.0</b>	<b>8.0</b>	<b>WD1700100</b>
<b>12.0</b>	<b>20.0</b>	<b>6.0</b>	<b>15.5</b>	<b>2.0</b>	<b>8.0</b>	<b>WD1700120</b>
<b>14.0</b>	<b>22.0</b>	<b>6.0</b>	<b>17.5</b>	<b>2.0</b>	<b>8.0</b>	<b>WD1700140</b>
15.0	23.0	6.0	18.5	2.0	8.0	WD1700150
<b>16.0</b>	<b>24.0</b>	<b>6.0</b>	<b>19.5</b>	<b>2.0</b>	<b>8.0</b>	<b>WD1700160</b>
<b>18.0</b>	<b>26.0</b>	<b>6.0</b>	<b>21.5</b>	<b>2.0</b>	<b>8.0</b>	<b>WD1700180</b>
<b>20.0</b>	<b>28.0</b>	<b>6.0</b>	<b>23.5</b>	<b>2.0</b>	<b>8.0</b>	<b>WD1700200</b>
<b>22.0</b>	<b>30.0</b>	<b>6.0</b>	<b>25.5</b>	<b>2.0</b>	<b>8.0</b>	<b>WD1700220</b>
24.0	32.0	6.0	27.5	2.0	8.0	WD1700240
<b>25.0</b>	<b>33.0</b>	<b>6.0</b>	<b>28.5</b>	<b>2.0</b>	<b>8.0</b>	<b>WD1700250</b>
<b>28.0</b>	<b>36.0</b>	<b>6.0</b>	<b>31.5</b>	<b>2.0</b>	<b>8.0</b>	<b>WD1700280</b>
30.0	38.0	6.0	33.5	2.0	8.0	WD1700300



Rod Diameter	Groove Diameter	Groove Width	Bore Diameter	Step Width	Width	TSS Part No.
$d_N$	D3	L <sub>3</sub>	D <sub>4</sub>	a <sub>min</sub>	B	
f8/h9	H9	+0.2	H11			
<b>32.0</b>	<b>40.0</b>	<b>6.0</b>	<b>35.5</b>	<b>2.0</b>	<b>8.0</b>	<b>WD1700320</b>
35.0	43.0	6.0	38.5	2.0	8.0	WD1700350
<b>36.0</b>	44.0	6.0	39.5	2.0	8.0	WD1700360
37.0	45.0	6.0	40.5	2.0	8.0	WD1700370
38.0	46.0	6.0	41.5	2.0	8.0	WD1700380
<b>40.0</b>	<b>48.0</b>	<b>6.0</b>	<b>43.5</b>	<b>2.0</b>	<b>8.0</b>	<b>WD1700400</b>
42.0	50.0	6.0	45.5	2.0	8.0	WD1700420
<b>45.0</b>	<b>53.0</b>	<b>6.0</b>	<b>48.5</b>	<b>2.0</b>	<b>8.0</b>	<b>WD1700450</b>
46.0	54.0	6.0	49.5	2.0	8.0	WD1700460
48.0	56.0	6.0	51.5	2.0	8.0	WD1700480
<b>50.0</b>	<b>58.0</b>	<b>6.0</b>	<b>53.5</b>	<b>2.0</b>	<b>8.0</b>	<b>WD1700500</b>
52.0	60.0	6.0	55.5	2.0	8.0	WD1700520
55.0	63.0	6.0	58.5	2.0	8.0	WD1700550
<b>56.0</b>	<b>64.0</b>	<b>6.0</b>	<b>59.5</b>	<b>2.0</b>	<b>8.0</b>	<b>WD1700560</b>
60.0	68.0	6.0	63.5	2.0	8.0	WD1700600
<b>63.0</b>	<b>71.0</b>	<b>6.0</b>	<b>66.5</b>	<b>2.0</b>	<b>8.0</b>	<b>WD1700630</b>
65.0	73.0	6.0	68.5	2.0	8.0	WD1700650
68.0	76.0	6.0	71.5	2.0	8.0	WD1700680
<b>70.0</b>	<b>78.0</b>	<b>6.0</b>	<b>73.5</b>	<b>2.0</b>	<b>8.0</b>	<b>WD1700700</b>
75.0	83.0	6.0	78.5	2.0	8.0	WD1700750
<b>80.0</b>	<b>88.0</b>	<b>6.0</b>	<b>83.5</b>	<b>2.0</b>	<b>8.0</b>	<b>WD1700800</b>
85.0	93.0	6.0	88.5	2.0	8.0	WD1700850
<b>90.0</b>	<b>98.0</b>	<b>6.0</b>	<b>93.5</b>	<b>2.0</b>	<b>8.0</b>	<b>WD1700900</b>
95.0	103.0	6.0	98.5	2.0	8.0	WD1700950
<b>100.0</b>	<b>108.0</b>	<b>6.0</b>	<b>103.5</b>	<b>2.0</b>	<b>8.0</b>	<b>WD1701000</b>
105.0	117.0	8.2	110.0	3.0	11.0	WD1701050
<b>110.0</b>	<b>122.0</b>	<b>8.2</b>	<b>115.0</b>	<b>3.0</b>	<b>11.0</b>	<b>WD1701100</b>
115.0	127.0	8.2	120.0	3.0	11.0	WD1701150
120.0	132.0	8.2	125.0	3.0	11.0	WD1701200
<b>125.0</b>	<b>137.0</b>	<b>8.2</b>	<b>130.0</b>	<b>3.0</b>	<b>11.0</b>	<b>WD1701250</b>
130.0	142.0	8.2	135.0	3.0	11.0	WD1701300
135.0	147.0	8.2	140.0	3.0	11.0	WD1701350
<b>140.0</b>	<b>152.0</b>	<b>8.2</b>	<b>145.0</b>	<b>3.0</b>	<b>11.0</b>	<b>WD1701400</b>
145.0	157.0	8.2	150.0	3.0	11.0	WD1701450
150.0	162.0	8.2	155.0	3.0	11.0	WD1701500
155.0	167.0	8.2	160.0	3.0	11.0	WD1701550
<b>160.0</b>	<b>172.0</b>	<b>8.2</b>	<b>165.0</b>	<b>3.0</b>	<b>11.0</b>	<b>WD1701600</b>
165.0	177.0	8.2	170.0	3.0	11.0	WD1701650
170.0	182.0	8.2	175.0	3.0	11.0	WD1701700
<b>180.0</b>	<b>192.0</b>	<b>8.2</b>	<b>185.0</b>	<b>3.0</b>	<b>11.0</b>	<b>WD1701800</b>
185.0	197.0	8.2	190.0	3.0	11.0	WD1701850
190.0	202.0	8.2	195.0	3.0	11.0	WD1701900



Rod Diameter	Groove Diameter	Groove Width	Bore Diameter	Step Width	Width	TSS Part No.
$d_N$	<b>D3</b>	<b>L<sub>3</sub></b>	<b>D<sub>4</sub></b>	<b>a<sub>min</sub></b>	<b>B</b>	
f8/h9	H9	+0.2	H11			
195.0	207.0	8.2	200.0	3.0	11.0	WD1701950
<b>200.0</b>	<b>212.0</b>	8.2	<b>205.0</b>	<b>3.0</b>	<b>11.0</b>	<b>WD1702000</b>
205.0	220.0	9.5	212.0	3.0	13.0	WD1702050
210.0	225.0	9.5	217.0	3.0	13.0	WD1702100
<b>220.0</b>	<b>235.0</b>	<b>9.5</b>	<b>227.0</b>	<b>3.0</b>	<b>13.0</b>	<b>WD1702200</b>
225.0	240.0	9.5	232.0	3.0	13.0	WD1702250
240.0	255.0	9.5	247.0	3.0	13.0	WD1702400
<b>250.0</b>	<b>265.0</b>	<b>9.5</b>	<b>257.0</b>	<b>3.0</b>	<b>13.0</b>	<b>WD1702500</b>
260.0	275.0	9.5	267.0	3.0	13.0	WD1702600
275.0	290.0	9.5	282.0	3.0	13.0	WD1702750
<b>280.0</b>	<b>295.0</b>	<b>9.5</b>	<b>287.0</b>	3.0	<b>13.0</b>	<b>WD1702800</b>
290.0	305.0	9.5	297.0	3.0	13.0	WD1702900
300.0	315.0	9.5	307.0	3.0	13.0	WD1703000
310.0	325.0	9.5	317.0	3.0	13.0	WD1703100
<b>320.0</b>	<b>335.0</b>	<b>9.5</b>	<b>327.0</b>	<b>3.0</b>	<b>13.0</b>	<b>WD1703200</b>
350.0	365.0	9.5	357.0	3.0	13.0	WD1703500
<b>360.0</b>	<b>375.0</b>	<b>9.5</b>	<b>367.0</b>	<b>3.0</b>	<b>13.0</b>	<b>WD1703600</b>
370.0	385.0	9.5	377.0	3.0	13.0	WD1703700
400.0	415.0	9.5	407.0	3.0	13.0	WD1704000
440.0	455.0	9.5	447.0	3.0	13.0	WD1704400

The rod diameters in **bold** type comply with the recommendations of ISO 3320.  
Intermediate sizes above 125 mm diameter can also be supplied in impact vulcanized form.  
Up to 18 mm diameter, we recommend a split groove.  
Other dimensions on request.

# Zurcon® Scraper DA22



---

Double-acting

---

**Material:**  
Zurcon®

---









## ■ Zurcon® Scraper DA22



### ■ Description

The scraper is a double-acting polyurethane wiper for closed groove installation. Significant improvements are achieved regarding the profile geometry and material used if compared with conventional elastomeric scrapers.

The scraper lip is designed in a particular way that it reliably scrapes off the dirt but leaves a residual oil film on the rod, which is required for correct operation. The radial squeeze is sufficient to remove particles, dust and water.

The scraping lip facing inwards is designed in a way that it assumes a sealing function even under low pressure. The static seal is achieved by a tight radial fit between the scraper body and the groove.

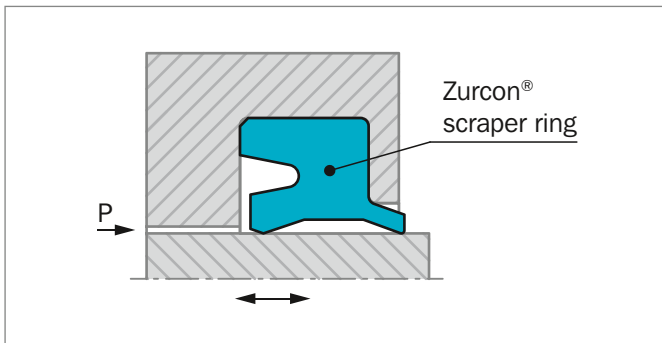

Figure 198: Scraper DA22

### ADVANTAGES

- Good scraping effect
- Wear resistant, long service life
- Retaining residual oil film
- Standard elements for standardized installation grooves.

### APPLICATION EXAMPLES

Due to the outstanding wiping capacities, DA22 scraper is recommended wherever there are dusty and humid conditions and especially for the following applications:

- ISO standard cylinders
- Hydraulic industrial cylinders
- Agriculture machinery

### OPERATING CONDITIONS

<b>Pressure</b>	Atmospheric pressure
<b>Scraper Side:</b>	
<b>Seal Side:</b>	Pressures up to 2 MPa (20 bar) a relief bore must be provided with higher pressures
<b>Speed:</b>	Up to 1 m/s
<b>Temperature:</b>	-35 °C to +100 °C
<b>Media:</b>	Mineral oils and greases
<b>Groove Type:</b>	Split/Closed (depending on size)

### IMPORTANT NOTE

The above data are maximum values and cannot be used at the same time, e.g. the maximum operating speed depends on material type, pressure, temperature and gap value. Temperature range also depends on media.

### MATERIALS

Standard application:

Zurcon® Polyurethane: 92 Shore A

Material Code: Z201

Color: Turquoise



## ■ Installation Recommendation

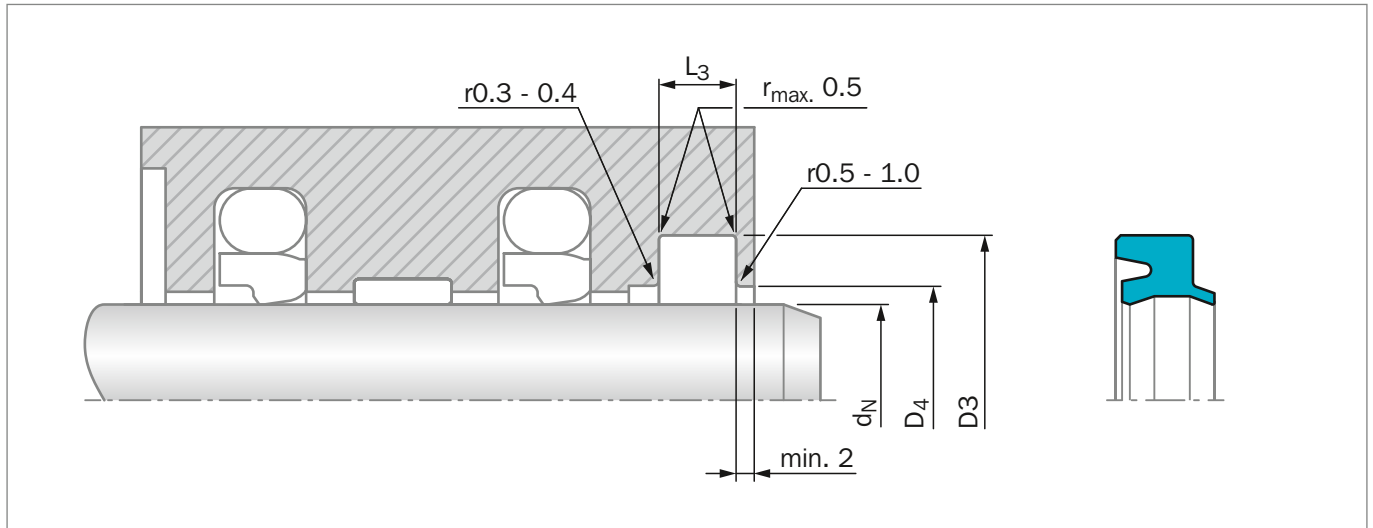

Figure 199: Installation Drawing

### ORDERING EXAMPLE

<b>Rod Diameter:</b>	$d_N = 36 \text{ mm}$
<b>Groove Diameter:</b>	$D3 = 44 \text{ mm}$
<b>Example 1</b>	
<b>TSS Part No.:</b>	WD2200360 from Table 186
<b>Material Code:</b>	Z201
<b>Old Ref. No.:</b>	Not available

<b>TSS Article No.</b>	<b>WD22 0 0360 - Z201</b>
TSS Series No.	WD22
Type (Standard)	0
Rod Diameter x 10	0360
Quality Index (Standard)	-
Material Code	Z201

Table 186: Installation Dimensions / TSS Part No.

Rod Diameter	Groove Diameter	Groove Width	Bore Diameter	TSS Part No.
$d_N$ f8/h9	D3 H9	L3 +0.2	D4 H11	
5.0	10.0	3.5	7.5	WD2200050
8.0	13.0	3.5	10.5	WD2200080
10.0	16.0	4.0	12.5	WD2200100
<b>12.0</b>	<b>18.0</b>	<b>4.0</b>	<b>14.5</b>	<b>WD2200120</b>
12.0	18.6	3.8	15.0	WD2210120
<b>14.0</b>	<b>20.0</b>	<b>4.0</b>	<b>16.5</b>	<b>WD2200140</b>
14.0	20.6	3.8	17.0	WD2210140
16.0	22.0	4.0	18.5	WD2200160
<b>18.0</b>	<b>24.0</b>	<b>4.0</b>	<b>20.5</b>	<b>WD2200180</b>
18.0	24.6	3.8	21.0	WD2210180



Rod Diameter	Groove Diameter	Groove Width	Bore Diameter	TSS Part No.
$d_N$ f8/h9	<b>D3</b> H9	<b>L<sub>3</sub></b> +0.2	<b>D4</b> H11	
20.0	26.0	4.0	22.5	WD2200200
20.0	28.6	5.3	23.0	WD2210200
<b>22.0</b>	<b>28.0</b>	<b>4.0</b>	<b>24.5</b>	<b>WD2200220</b>
22.0	30.6	5.3	25.0	WD2210220
24.0	32.6	5.3	27.0	WD2210240
25.0	31.0	4.0	27.5	WD2200250
25.0	33.6	5.3	28.0	WD2210250
<b>28.0</b>	<b>36.0</b>	<b>5.0</b>	<b>31.0</b>	<b>WD2200280</b>
28.0	36.6	5.3	31.0	WD2210280
30.0	38.0	5.0	33.0	WD2200300
30.0	38.6	5.3	33.0	WD2210300
32.0	40.0	5.0	35.0	WD2200320
35.0	43.0	5.0	38.0	WD2200350
35.0	43.6	5.3	38.0	WD2210350
<b>36.0</b>	<b>44.0</b>	<b>5.0</b>	<b>39.0</b>	<b>WD2200360</b>
36.0	44.6	5.3	39.0	WD2210360
40.0	48.0	5.0	43.0	WD2200400
40.0	48.6	5.3	43.0	WD2210400
<b>45.0</b>	<b>53.0</b>	<b>5.0</b>	<b>48.0</b>	<b>WD2200450</b>
45.0	53.6	5.3	48.0	WD2210450
50.0	58.0	5.0	53.0	WD2200500
50.0	58.6	5.3	53.0	WD2210500
55.0	63.6	5.3	58.0	WD2210550
55.0	65.0	6.0	58.0	WD2200550
56.0	64.6	5.3	59.0	WD2210560
<b>56.0</b>	<b>66.0</b>	<b>6.0</b>	<b>59.0</b>	<b>WD2200560</b>
60.0	68.6	5.3	63.0	WD2210600
60.0	70.0	6.0	63.0	WD2200600
63.0	71.6	5.3	66.0	WD2210630
63.0	73.0	6.0	66.0	WD2200630
65.0	75.0	6.0	68.0	WD2200650
70.0	78.6	5.3	73.0	WD2210700
<b>70.0</b>	<b>80.0</b>	<b>6.0</b>	<b>73.0</b>	<b>WD2200700</b>
75.0	83.6	5.3	78.0	WD2210750
75.0	85.0	6.0	78.0	WD2200750
80.0	88.6	5.3	83.0	WD2210800
80.0	90.0	6.0	83.0	WD2200800
85.0	95.0	6.0	88.0	WD2200850
85.0	97.2	7.1	91.0	WD2210850
<b>90.0</b>	<b>100.0</b>	<b>6.0</b>	<b>93.0</b>	<b>WD2200900</b>
90.0	102.2	7.1	96.0	WD2210900
100.0	110.0	6.0	103.0	WD2201000



Rod Diameter	Groove Diameter	Groove Width	Bore Diameter	TSS Part No.
$d_N$ f8/h9	<b>D3</b> H9	<b>L<sub>3</sub></b> +0.2	<b>D<sub>4</sub></b> H11	
100.0	112.2	7.1	106.0	WD2211000
110.0	122.2	7.1	116.6	WD2211100
<b>110.0</b>	<b>125.0</b>	<b>8.5</b>	<b>114.0</b>	<b>WD2201100</b>
120.0	135.0	8.5	124.0	WD2201200
125.0	140.0	8.5	129.0	WD2201250
<b>140.0</b>	<b>155.0</b>	<b>8.5</b>	<b>144.0</b>	<b>WD2201400</b>
150.0	165.0	8.5	154.0	WD2201500
160.0	175.0	8.5	164.0	WD2201600
180.0	195.0	8.5	184.0	WD2201800

The sizes in **bold** type comply with ISO 6195. Installation groove Type C.  
Up to 18 mm diameter we recommend a split groove.  
Other sizes on request.

# Zurcon® Scraper DA24 & Venting Version



---

Double-acting

---

**Material:**  
Zurcon®

---







## ■ Zurcon® Scraper DA24



### ■ Description

Zurcon® DA24 is a double-acting thermoplastic polyurethane scraper for severe operating conditions and heavy attack of dirt.

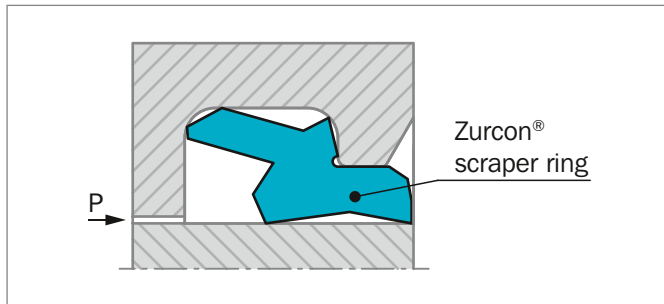

Figure 200: Scraper DA24: Standard Version

A new improved design available now in two different versions has been recently developed by Trelleborg Sealing Solutions to enhance the overall performances.

The special design of the inward-facing sealing lip contributes to an optimum contact pressure resulting in a very high scraper effect of the residual oil film thanks to the sharp, knife cut, scraping lip.

The outer scraper lip leans against the housing. This ensures an optimum sealing force and further it prevents the ingress of dirt and water across the groove bottom. Also in case of high level of external contamination and dirt or rod eccentricity under side load the scraper effect remains stable. The improved design reduces the friction with less heat generated and a longer service life.

The new design of DA24 is now available in two versions: standard and venting.

DA24 is produced in Zurcon®, the Trelleborg Sealing Solutions proprietary thermoplastic polyurethane material specially developed for sealing applications. This provides long service life under harsh working conditions and resistance against installation damage

### ADVANTAGES

- Very good scraper effect of the outward lip
- Very good sealing effect due to a trimmed inner sealing lip: Provides optimum contact pressure for efficient sealing and wiping of residual oil film
- Reliable at side steering of the piston rod
- Sturdy and wear-resistant
- Simple installation
- Advanced friction characteristics
- Limited heat generation extending service life
- Stability in the groove securing function
- Robust outer scraper lip supported by a housing recess, it ensures a high contact force on the rod

### VENTING VERSION FEATURE

In some situations when there is pressure build-up behind the scraper, the scraper can be pushed out of the groove causing total sealing system failure.

Zurcon® Scraper DA24 Venting Version has axial holes through the section which operate as pressure relief valves, allowing oil to be released in the case of overpressure.

Once the pressure is build-up the outer lip is temporarily activated through the axial holes and the pressure is released avoiding system failure. With improved stability in the groove the Zurcon® Scraper DA24 Venting Version becomes one of the most efficient scrapers available on the market.

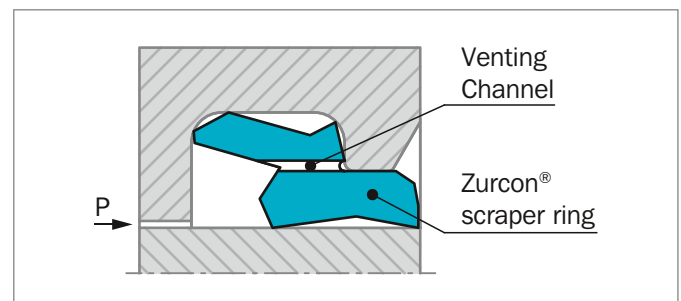
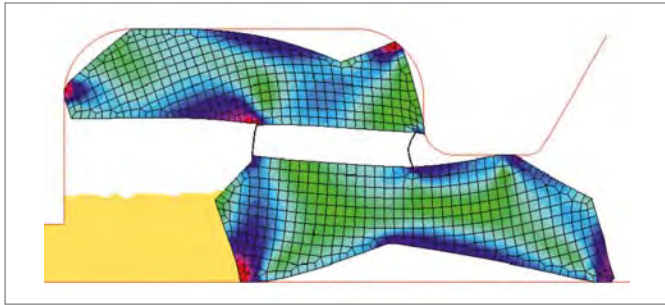

Figure 201: Scraper DA24: Venting Version



### METHOD OF OPERATION FOR VENTING VERSION



1. Pressurized oil flows through holes in the profile at the top of the scraping lip.

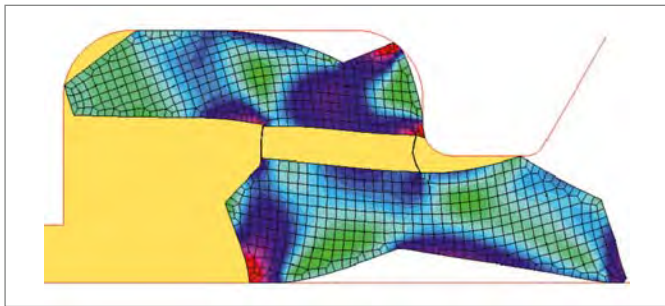

2. The scraping lip is pressed to the rod during pressure build-up.

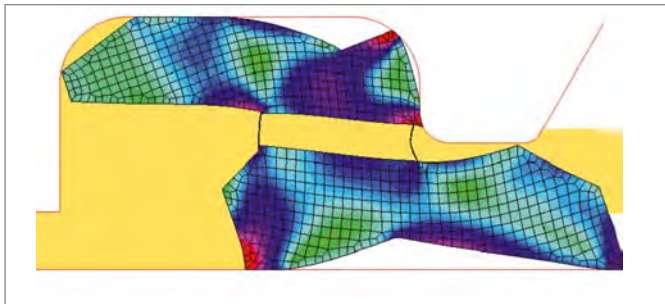

3. A gap opens up between scraping lip and housing at a certain pressure level.

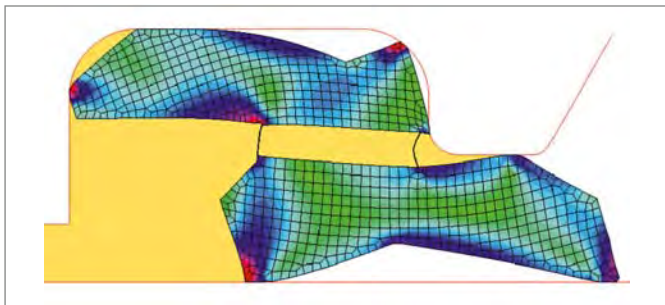

4. The oil is released and pressure is relieved.

### APPLICATION EXAMPLES

The scraper DA24 is especially suitable for application in:

- Construction machinery
- Agriculture- and forestry machinery
- Mobile hydraulic
- High attack of dirt
- Side steering of piston rod

### OPERATING CONDITIONS

<b>Pressure:</b>	standard version: max. 5 MPa venting version: max. 2 MPa
<b>Velocity:</b>	Up to 1 m/s at high strokes and higher speed, please contact your local Trelleborg Sealing Solutions company
<b>Temperature:</b>	-35 °C to +100 °C
<b>Media:</b>	Hydraulic fluids based on mineral oil

### MATERIALS – STANDARD APPLICATION:

The scraper DA24 consists of Zurcon® polyurethane material with excellent wear and extrusion resistance and low deformation under load.

Special Polyurethane: Zurcon® Z201 92 Shore A  
Set reference: Z201  
Color: Turquoise

### PREMIUM MATERIALS – HYDROLYSIS RESISTANCE:

Zurcon® Z24 Premium polyurethane

Set reference: Z24

The Zurcon® polyurethane has high abrasion resistance, a low compression set, high extrusion resistance and a wide temperature range.

### IMPORTANT NOTE

The above data are maximum values and cannot be used at the same time, e.g. the maximum operating speed depends on material type, pressure, temperature and gap value. Temperature range also depends on media.





## ■ Installation Recommendation

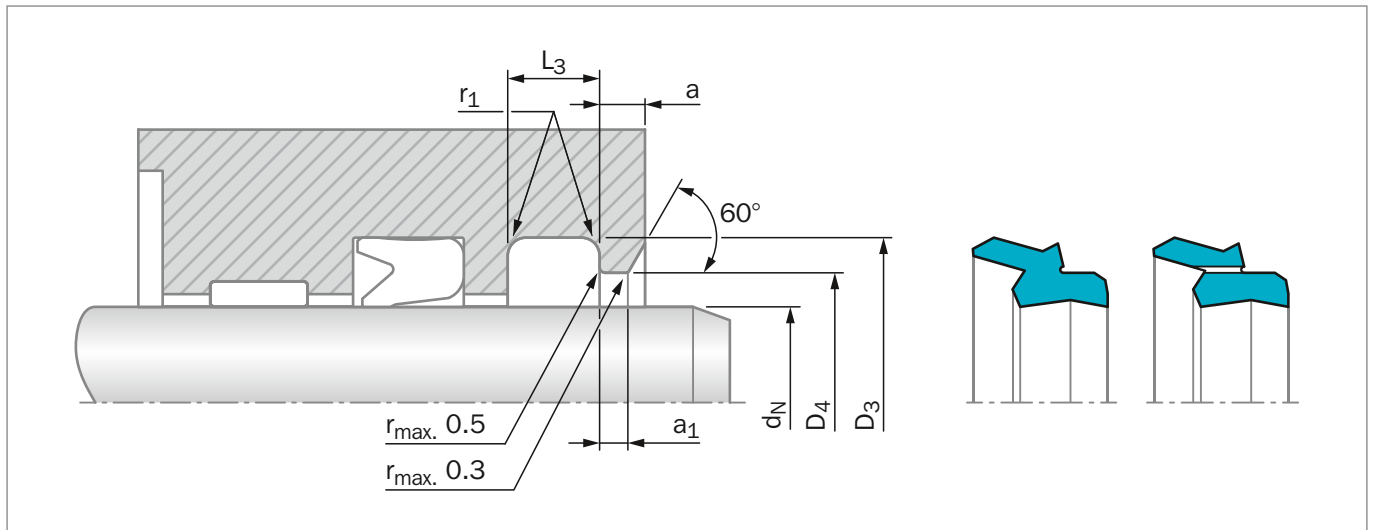

Figure 202: Installation Drawing

**Table 187: Preferred Series / Order No.**

Rod Diameter	Groove Diameter	Groove Width	Radius	Bore Diameter	Step Width	Step Width	TSS Article No. Standard Version
$d_N$ f8/h9	$D_3$ H9	$L_3$ +0.2	$r_1$ max.	$D_4$ H9	$a$ min.	$a_1$ min.	
45.0	53.8	6.3	1.2	49.4	3.2	2.0	WD2410450
50.0	58.8	6.3	1.2	54.4	3.2	2.0	WD2410500
56.0	64.8	6.3	1.2	60.4	3.2	2.0	WD2410560
60.0	68.8	6.3	1.2	64.4	3.2	2.0	WD2410600
70.0	82.2	8.1	1.6	76.0	4.0	2.5	WD2410700
75.0	87.2	8.1	1.6	81.0	4.0	2.5	WD2410750
80.0	92.2	8.1	1.6	86.0	4.0	2.5	WD2410800
85.0	97.2	8.1	1.6	91.0	4.0	2.5	WD2410850
90.0	102.2	8.1	1.6	96.0	4.0	2.5	WD2410900
95.0	107.2	8.1	1.6	101.0	4.0	2.5	WD2410950
100.0	112.2	8.1	1.6	106.0	4.0	2.5	WD2411000
105.0	117.2	8.1	1.6	111.0	4.0	2.5	WD2411050
110.0	122.2	8.1	1.6	116.0	4.0	2.5	WD2411100
115.0	127.2	8.1	1.6	121.0	4.0	2.5	WD2411150
125.0	137.2	8.1	1.6	131.0	4.0	2.5	WD2411250
140.0	156.0	9.5	2.0	148.0	5.0	3.0	WD2411400
150.0	166.0	9.5	2.0	158.0	5.0	3.0	WD2411500
160.0	176.0	9.5	2.0	168.0	5.0	3.0	WD2411600
170.0	186.0	9.5	2.0	178.0	5.0	3.0	WD2411700
180.0	196.0	9.5	2.0	188.0	5.0	3.0	WD2411800



Rod Diameter	Groove Diameter	Groove Width	Radius	Bore Diameter	Step Width	Step Width	TSS Article No. Standard Version
$d_N$ f8/h9	$D_3$ H9	$L_3$ +0.2	$r_1$ max.	$D_4$ H9	$a$ min.	$a_1$ min.	
200.0	216.0	9.5	2.0	208.0	5.0	3.0	WD2412000
220.0	236.0	9.5	2.0	228.0	5.0	3.0	WD2412200
240.0	256.0	9.5	2.0	248.0	5.0	3.0	WD2412400
260.0	276.0	9.5	2.0	268.0	5.0	3.0	WD2412600
280.0	296.0	9.5	2.0	288.0	5.0	3.0	WD2412800
290.0	306.0	9.5	2.0	298.0	5.0	3.0	WD2412900

Other dimensions on request

### ORDERING EXAMPLE

Standard Version:

<b>Rod Diameter:</b>	$d_N = 50$ mm
<b>Groove Diameter:</b>	$D_3 = 58.8$ mm
<b>Groove Width:</b>	$L_3 = 6.3$ mm
<b>TSS Article No.:</b>	WD2410500 from Table 187
<b>Material:</b>	Standard material Z201

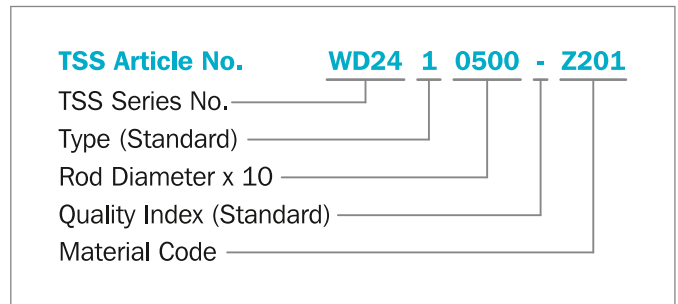

Venting Version:

<b>Rod Diameter:</b>	$d_N = 140$ mm
<b>Groove Diameter:</b>	$D_3 = 156$ mm
<b>Groove Width:</b>	$L_3 = 9.5$ mm
<b>TSS Article No.:</b>	WD24H1400
<b>Material:</b>	Standard material Z201

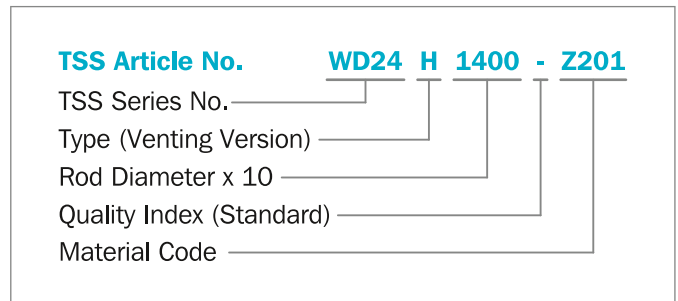

# Scraper WRM



---

Single-acting

---

**Material:**  
NBR Elastomer

---







## ■ Scraper WRM



### ■ Description

Scraper rings are essential components of any hydraulic or pneumatic equipment.

These are protection components for axial moving rods: they ensure that foreign matter is not introduced into the system, avoiding costly wear and damage to all the internal components including seals.

WRM scrapers are manufactured in nitrile elastomer with precision machined wiper lip, which produces a very effective wiping action.

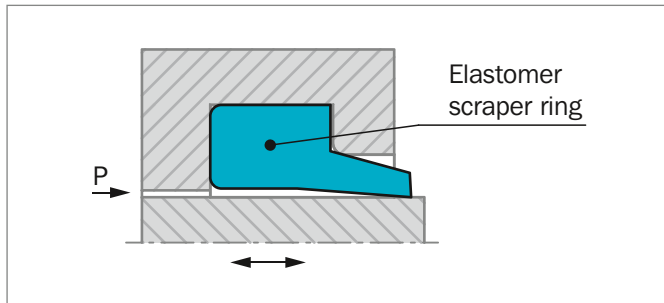

Figure 203: Scraper WRM

### ADVANTAGES

- Space-saving construction
- Low cost, economical solution
- Simple, easy-construction groove
- Easy installation and removal without tools

### APPLICATION EXAMPLES

Due to their outstanding wiping capacities WRM scrapers are recommended wherever there are dusty and humid conditions and especially for the following applications:

- Valve spindles
- Slide valves
- Hydraulic cylinders
- Agriculture machinery

### OPERATING CONDITIONS

<b>Speed:</b>	Up to 1 m/s
<b>Temperature:</b>	-30 °C to +110 °C
<b>Media:</b>	Mineral oil based hydraulic fluids, polyglycol-water emulsions, water-oil emulsions
<b>Groove Type:</b>	Closed

### IMPORTANT NOTE

The above data are maximum values and cannot be used at the same time, e.g. the maximum operating speed depends on material type, pressure, temperature and gap value. Temperature range also depends on media.

### MATERIALS

Standard application

Nitrile elastomer: NBR 90 Shore A

Material Code: N9T60

Polypac Ref. code: 2790



## ■ Installation Recommendation

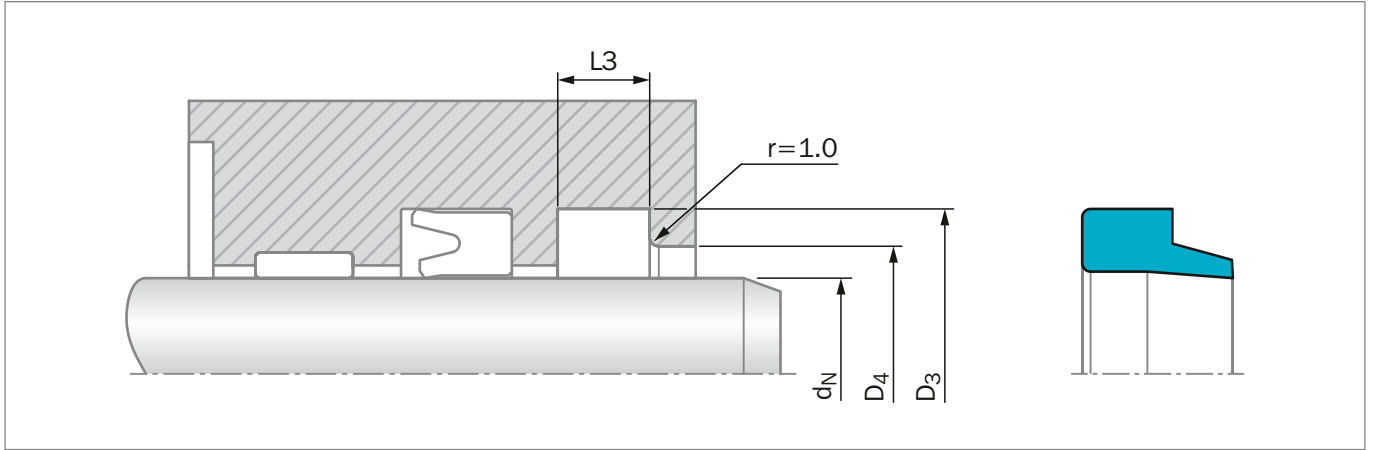
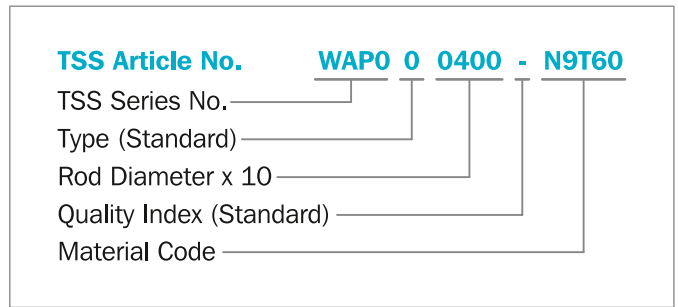

Figure 204: Installation Drawing

### ORDERING EXAMPLE

<b>Rod Diameter:</b>	$d_N = 40 \text{ mm}$
<b>TSS Part No.:</b>	WAP000400 from Table 188
<b>Material Code:</b>	N9T60 (standard)
<b>Polypac Ref.:</b>	WRM 157188



**Table 188: Installation Dimensions / TSS Part No.**

Rod Diameter	Groove Diameter	Groove Width	Bore Diameter	TSS Part No.	Description
$d_N$ f8/h9	$D_3$ H9	$L_3$ +0.2	$D_4$ +0.2		
12.0	18.6	3.8	15.0	WAP000120	WRM047070
13.0	19.6	3.8	16.0	WAP000130	WRM051074
14.0	20.6	3.8	17.0	WAP000140	WRM055078
15.0	21.6	3.8	18.0	WAP000150	WRM059082
16.0	22.6	3.8	19.0	WAP000160	WRM062087
17.0	23.6	3.8	20.0	WAP000170	WRM066094
18.0	24.6	3.8	21.0	WAP000180	WRM070094
19.0	28.6	5.3	22.0	WAP000190	WRM074110
20.0	28.6	5.3	23.0	WAP000200	WRM078110
22.0	30.6	5.3	25.0	WAP000220	WRM086118
24.0	32.6	5.3	27.0	WAP000240	WRM094125
25.0	31.6	5.3	28.0	WAP100250	WRM098122/S
25.0	33.6	5.3	28.0	WAP000250	WRM098129
26.0	34.6	5.3	29.0	WAP000260	WRM102133



Rod Diameter	Groove Diameter	Groove Width	Bore Diameter	TSS Part No.	Description
$d_N$ f8/h9	$D_3$ H9	$L_3$ +0.2	$D_4$ +0.2		
27.0	35.6	5.3	30.0	<a href="#">WAP000270</a>	WRM106137
28.0	36.6	5.3	31.0	<a href="#">WAP000280</a>	WRM110141
30.0	38.6	5.3	33.0	<a href="#">WAP000300</a>	WRM118149
31.0	41.0	6.0	34.0	<a href="#">WAP000310</a>	WRM4544907
32.0	40.6	5.3	35.0	<a href="#">WAP000320</a>	WRM125157
33.0	41.6	5.3	36.0	<a href="#">WAP000330</a>	WRM129161
35.0	43.6	5.3	38.0	<a href="#">WAP000350</a>	WRM137169
36.0	44.6	5.3	39.0	<a href="#">WAP000360</a>	WRM141173
38.0	46.6	5.3	41.0	<a href="#">WAP000380</a>	WRM149181
40.0	48.6	5.3	43.0	<a href="#">WAP000400</a>	WRM157188
42.0	50.6	5.3	45.0	<a href="#">WAP000420</a>	WRM165196
45.0	53.6	5.3	48.0	<a href="#">WAP000450</a>	WRM177208
45.0	55.6	5.3	49.0	<a href="#">WAP100450</a>	WRM177216
46.0	54.6	5.3	49.0	<a href="#">WAP000460</a>	WRM181212
48.0	56.6	5.3	51.0	<a href="#">WAP000480</a>	WRM188220
49.0	57.6	5.3	52.0	<a href="#">WAP000490</a>	WRM193225
50.0	58.6	5.3	53.0	<a href="#">WAP000500</a>	WRM196228
50.0*	60.6	5.3	54.0	<a href="#">WAP100500</a>	WRM196236
50.8	60.9	5.8	55.5	<a href="#">WAP000508</a>	WRM200237
53.0*	61.6	5.3	56.0	<a href="#">WAP000530</a>	WRM208240
55.0*	63.6	5.3	58.0	<a href="#">WAP000550</a>	WRM216248
55.0	65.6	5.3	59.0	<a href="#">WAP100550</a>	WRM216255
60.0	68.6	5.3	63.0	<a href="#">WAP000600</a>	WRM236267
63.0*	71.6	5.3	66.0	<a href="#">WAP000630</a>	WRM248279
63.0	73.6	5.3	67.0	<a href="#">WAP100630</a>	WRM248287
65.0	73.6	5.3	68.0	<a href="#">WAP000650</a>	WRM255287
65.0	75.6	5.3	69.0	<a href="#">WAP100650</a>	WRM255295
70.0*	76.0	4.3	72.0	<a href="#">WAP000700</a>	WRM275299
70.0	78.6	5.3	73.0	<a href="#">WAP100700</a>	WRM275307
70.0	80.6	5.3	72.0	<a href="#">WAP200700</a>	WRM275314
70.0	82.6	7.1	76.0	<a href="#">WAP300700</a>	WRM275322
72.0	80.6	5.3	75.0	<a href="#">WAP000720</a>	WRM283317
73.0	81.6	5.3	76.0	<a href="#">WAP000730</a>	WRM287318
75.0	83.6	5.3	78.0	<a href="#">WAP000750</a>	WRM295326
75.0	87.2	7.1	81.0	<a href="#">WAP100750</a>	WRM295345
76.5	88.7	7.1	82.5	<a href="#">WAP000765</a>	WRM301348
78.0	92.2	7.1	85.0	<a href="#">WAP000780</a>	WRM307362
80.0	88.6	5.3	83.0	<a href="#">WAP000800</a>	WRM314346
80.0	92.6	7.1	86.0	<a href="#">WAP100800</a>	WRM314362
83.0	91.6	5.3	86.0	<a href="#">WAP000830</a>	WRM326358
84.0	92.0	5.3	87.0	<a href="#">WAP000840</a>	WRM330362
85.0	93.6	5.3	88.0	<a href="#">WAP000850</a>	WRM334366



Rod Diameter	Groove Diameter	Groove Width	Bore Diameter	TSS Part No.	Description
$d_N$ f8/h9	$D_3$ H9	$L_3$ +0.2	$D_4$ +0.2		
85.0	97.2	7.1	91.0	<a href="#">WAP100850</a>	WRM334381
88.0	100.2	7.1	94.0	<a href="#">WAP000880</a>	WRM346393
90.0	102.2	7.1	96.0	<a href="#">WAP000900</a>	WRM354401
95.0	107.2	7.1	101.0	<a href="#">WAP000950</a>	WRM374421
97.0	111.0	7.1	104.0	<a href="#">WAP000970</a>	WRM380437
100.0	112.2	7.1	106.0	<a href="#">WAP001000</a>	WRM393440
101.0	111.0	5.3	105.0	<a href="#">WAP001010</a>	WRM397437
103.0	115.2	7.1	109.0	<a href="#">WAP001030</a>	WRM405452
104.0	116.2	7.1	110.0	<a href="#">WAP001040</a>	WRM409457
105.0	117.2	7.1	111.0	<a href="#">WAP001050</a>	WRM413460
110.0	122.2	7.1	116.0	<a href="#">WAP001100</a>	WRM433480
115.0	127.2	7.1	121.0	<a href="#">WAP001150</a>	WRM452500
116.0	128.2	7.1	121.0	<a href="#">WAP001160</a>	WRM456504
116.0	130.2	7.1	123.0	<a href="#">WAP101160</a>	WRM456511
118.0*	130.2	7.1	124.0	<a href="#">WAP001180</a>	WRM464511
120.0	128.6	5.3	123.0	<a href="#">WAP001200</a>	WRM472504
120.0	132.2	7.1	126.0	<a href="#">WAP101200</a>	WRM472519
121.0*	131.0	5.3	125.0	<a href="#">WAP001210</a>	WRM476515
125.0	137.2	7.1	131.0	<a href="#">WAP001250</a>	WRM492539
127.0	135.6	5.3	132.0	<a href="#">WAP001270</a>	WRM500531
127.0	139.2	7.1	133.0	<a href="#">WAP101270</a>	WRM500550
130.0	142.2	7.1	136.0	<a href="#">WAP001300</a>	WRM511559
135.0	147.2	7.1	141.0	<a href="#">WAP001350</a>	WRM531578
135.0	149.2	7.1	142.0	<a href="#">WAP101350</a>	WRM531582
140.0	152.2	7.1	146.0	<a href="#">WAP001400</a>	WRM551598
140.0	155.2	10.1	147.0	<a href="#">WAP101400</a>	WRM551610
145.0	157.2	7.1	151.0	<a href="#">WAP001450</a>	WRM570618
146.0*	158.0	6.3	152.0	<a href="#">WAP001460</a>	WRM575622/1
146.05	158.25	7.1	152.05	<a href="#">WAP001461</a>	WRM575622
150.0*	162.2	7.1	156.0	<a href="#">WAP001500</a>	WRM590637
155.0	169.2	7.1	162.0	<a href="#">WAP001550</a>	WRM610664
160.0	168.6	5.3	163.0	<a href="#">WAP001600</a>	WRM629661
160.0	175.2	10.1	168.0	<a href="#">WAP101600</a>	WRM629688
165.0	173.6	5.3	168.0	<a href="#">WAP001650</a>	WRM649681
165.0	177.2	7.1	171.0	<a href="#">WAP101650</a>	WRM649698
170.0	180.6	5.3	174.0	<a href="#">WAP001700</a>	WRM669708
170.0	185.2	10.1	178.0	<a href="#">WAP101700</a>	WRM669728
171.0	183.0	6.3	176.0	<a href="#">WAP001710</a>	WRM673720
175.0	189.2	7.1	182.0	<a href="#">WAP001750</a>	WRM688744
180.0	195.2	10.1	188.0	<a href="#">WAP001800</a>	WRM708767
187.0*	195.6	5.3	190.0	<a href="#">WAP001870</a>	WRM736768
196.0	210.2	7.1	203.0	<a href="#">WAP001960</a>	WRM771826





Rod Diameter	Groove Diameter	Groove Width	Bore Diameter	TSS Part No.	Description
$d_N$ f8/h9	$D_3$ H9	$L_3$ +0.2	$D_4$ +0.2		
197.0	219.0	6.3	202.0	<a href="#">WAP001970</a>	WRM775823
200.0	215.2	10.1	207.0	<a href="#">WAP002000</a>	WRM787847
210.0	224.2	7.1	217.0	<a href="#">WAP002100</a>	WRM826883
210.0	225.0	7.0	217.0	<a href="#">WAP102100</a>	WRM826885
219.5	233.7	7.1	226.5	<a href="#">WAP002195</a>	WRM860919
223.0	235.0	6.3	228.0	<a href="#">WAP002230</a>	WRM878925
244.5	258.7	7.1	251.5	<a href="#">WAP002445</a>	WRM9621017
249.0	261.0	6.3	254.0	<a href="#">WAP002490</a>	WRM9801027
260.0	275.2	10.1	268.0	<a href="#">WAP002600</a>	WRM10241078

\* Available upon request

---

! This page is intentionally left blank.

# Zurcon® Scraper ASW



---

Single-acting

---

**Material:**  
Zurcon®

---







## ■ Zurcon® Scraper ASW

### ■ Description

The scraper ASW is a single-acting polyurethane scraper.

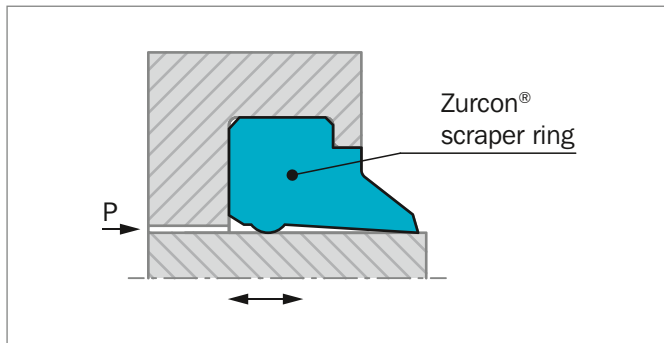

Figure 205: Scraper ASW

The special feature of this scraper is an additional supporting bead on the inner surface. It prevents tilting or twisting of the scraper in the groove. At the same time this support improves the firm seating in the groove, thus preventing the penetration of impurities via the back of the scraper. This represents a technical improvement compared with similar scraper types.

### ADVANTAGES

- Simple groove design
- Very good scraping effect, wear resistant
- No tilting or twisting in the groove
- Simple installation
- Flush fitting with the outer surface

### OPERATING CONDITIONS

<b>Speed:</b>	Up to 1 m/s
<b>Temperature:</b>	-35 °C to +100 °C
<b>Media:</b>	Mineral oil-based hydraulic fluids

### IMPORTANT NOTE

The above data are maximum values and cannot be used at the same time, e.g. the maximum operating speed depends on material type, pressure, temperature and gap value. Temperature range also depends on media.

### MATERIAL

The standard material is a wear resistant Zurcon® polyurethane.

Standard material: Polyurethane, 92 Shore A  
Material No. Z201

Color: Turquoise



## ■ Installation Recommendation

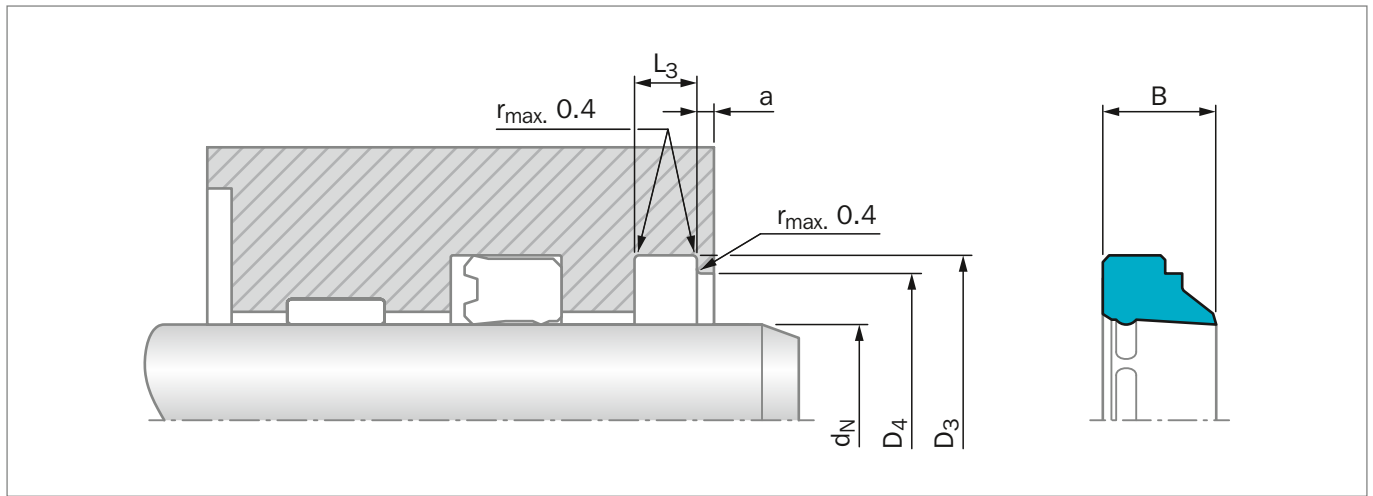

Figure 206: Installation Drawing

### ORDERING EXAMPLE

Scraper ASW

<b>Rod Diameter:</b>	$d_N = 50.0 \text{ mm}$
<b>TSS Part No.:</b>	WSW000500 from Table 189
<b>Material:</b>	Z201

**TSS Article No.**      **WSW0 0 0500 - Z201**

TSS Series No. ————|

Type (Standard) ————|

Rod Diameter x 10 ————|

Quality Index (Standard) ————|

Material Code ————|

**Table 189: Installation Dimensions / TSS Part No.**

Rod Diameter $d_N$ f8/h9	Groove Diameter $D_3$ H9	Groove Width $L_3$ +0.2	Bore Diameter $D_4$ H11	Step Width $a$ min	Width $B$	TSS Part No.
6.0	10.0	2.0	9.0	1.0	4.0	WSW000060
8.0	14.0	2.6	12.0	1.0	5.0	WSW000080
10.0	16.0	2.6	14.0	1.0	5.0	WSW000100
12.0	18.0	2.6	16.0	1.0	5.0	WSW000120
14.0	20.0	2.6	18.0	1.0	5.0	WSW000140
14.0	22.0	4.0	20.0	1.0	7.0	WSW100140
15.0	23.0	4.0	21.0	1.0	7.0	WSW000150
16.0	24.0	4.0	22.0	1.0	7.0	WSW000160
18.0	26.0	4.0	24.0	1.0	7.0	WSW000180
20.0	26.0	2.6	24.0	1.0	5.0	WSW100200
20.0	28.0	4.0	26.0	1.0	7.0	WSW000200
22.0	30.0	4.0	28.0	1.0	7.0	WSW000220



Rod Diameter	Groove Diameter	Groove Width	Bore Diameter	Step Width	Width	TSS Part No.
$d_N$ f8/h9	$D_3$ H9	$L_3$ +0.2	$D_4$ H11	$a$ min	$B$	
24.0	32.0	4.0	30.0	1.0	7.0	WSW000240
<b>25.0</b>	<b>33.0</b>	<b>4.0</b>	<b>31.0</b>	<b>1.0</b>	<b>7.0</b>	<b>WSW000250</b>
<b>28.0</b>	<b>36.0</b>	<b>4.0</b>	<b>34.0</b>	<b>1.0</b>	<b>7.0</b>	<b>WSW000280</b>
30.0	38.0	4.0	36.0	1.0	7.0	WSW000300
<b>32.0</b>	<b>40.0</b>	<b>4.0</b>	<b>38.0</b>	<b>1.0</b>	<b>7.0</b>	<b>WSW000320</b>
34.0	42.0	4.0	40.0	1.0	7.0	WSW000340
35.0	43.0	4.0	41.0	1.0	7.0	WSW000350
<b>36.0</b>	<b>44.0</b>	<b>4.0</b>	<b>42.0</b>	<b>1.0</b>	<b>7.0</b>	<b>WSW000360</b>
38.0	46.0	4.0	44.0	1.0	7.0	WSW000380
<b>40.0</b>	<b>48.0</b>	<b>4.0</b>	<b>46.0</b>	<b>1.0</b>	<b>7.0</b>	<b>WSW000400</b>
42.0	50.0	4.0	48.0	1.0	7.0	WSW000420
<b>45.0</b>	<b>53.0</b>	<b>4.0</b>	<b>51.0</b>	<b>1.0</b>	<b>7.0</b>	<b>WSW000450</b>
<b>50.0</b>	<b>58.0</b>	<b>4.0</b>	<b>56.0</b>	<b>1.0</b>	<b>7.0</b>	<b>WSW000500</b>
52.0	60.0	4.0	58.0	1.0	7.0	WSW000520
55.0	63.0	4.0	61.0	1.0	7.0	WSW000550
<b>56.0</b>	<b>64.0</b>	<b>4.0</b>	<b>62.0</b>	<b>1.0</b>	<b>7.0</b>	<b>WSW000560</b>
60.0	68.0	4.0	66.0	1.0	7.0	WSW000600
<b>63.0</b>	<b>71.0</b>	<b>4.0</b>	<b>69.0</b>	<b>1.0</b>	<b>7.0</b>	<b>WSW000630</b>
65.0	73.0	4.0	71.0	1.0	7.0	WSW000650
<b>70.0</b>	<b>78.0</b>	<b>4.0</b>	<b>76.0</b>	<b>1.0</b>	<b>7.0</b>	<b>WSW000700</b>
75.0	83.0	4.0	81.0	1.0	7.0	WSW000750
<b>80.0</b>	<b>88.0</b>	<b>4.0</b>	<b>86.0</b>	<b>1.0</b>	<b>7.0</b>	<b>WSW000800</b>
85.0	93.0	4.0	91.0	1.0	7.0	WSW000850
<b>90.0</b>	<b>98.0</b>	<b>4.0</b>	<b>96.0</b>	<b>1.0</b>	<b>7.0</b>	<b>WSW000900</b>
<b>100.0</b>	<b>108.0</b>	<b>4.0</b>	<b>106.0</b>	<b>1.0</b>	<b>7.0</b>	<b>WSW001000</b>
105.0	113.0	4.0	111.0	1.0	7.0	WSW001050
<b>110.0</b>	<b>122.0</b>	<b>5.5</b>	<b>119.0</b>	<b>1.5</b>	<b>10.0</b>	<b>WSW001100</b>
120.0	132.0	5.5	129.0	1.5	10.0	WSW001200
<b>125.0</b>	<b>137.0</b>	<b>5.5</b>	<b>134.0</b>	<b>1.5</b>	<b>10.0</b>	<b>WSW001250</b>
<b>140.0</b>	<b>152.0</b>	<b>5.5</b>	<b>149.0</b>	<b>1.5</b>	<b>10.0</b>	<b>WSW001400</b>
150.0	162.0	5.5	159.0	1.5	10.0	WSW001500
<b>160.0</b>	<b>172.0</b>	<b>5.5</b>	<b>169.0</b>	<b>1.5</b>	<b>10.0</b>	<b>WSW001600</b>

The rod diameters in **bold** type comply with the recommendations of ISO 3320.  
Other dimensions on request.

A split groove is required up to 14 mm diameter.

---

! This page is intentionally left blank.



# Zurcon® Scraper WNE



---

Single-acting

---

Dynamic + Static Sealing Lip

**Material:**

Zurcon®

---







## ■ Zurcon® Scraper WNE



### ■ Description

These scrapers are manufactured in polyurethane. The static sealing lip ensures against the intrusion of dirt and fluids over the outer diameter.

The scraper WNE has an interference to the groove outside diameter.

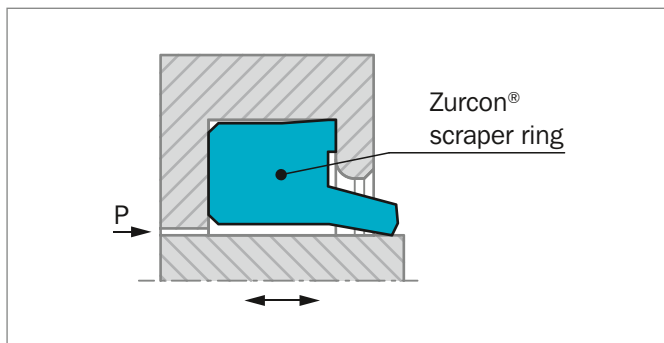

Figure 207: Scraper WNE

### ADVANTAGES

- High wear resistance
- Good prevention against external fluid intrusion
- Easy installation
- Space-saving construction

### APPLICATION EXAMPLES

These scrapers are recommended wherever there are dusty and humid conditions and especially for the following applications:

- Mobile hydraulic machinery
- Agriculture machinery

### OPERATING CONDITIONS

<b>Speed:</b>	Up to 1 m/s
<b>Temperature:</b>	-35 °C to +100 °C
<b>Media:</b>	Mineral oil based hydraulic fluids
<b>Groove Type:</b>	Closed

### IMPORTANT NOTE

The above data are maximum values and cannot be used at the same time, e.g. the maximum operating speed depends on material type, pressure, temperature and gap value. Temperature range also depends on media.

### MATERIALS

Zurcon® Polyurethane:	92 Shore A
Material code:	Z201
Color:	Turquoise



## Installation Recommendation

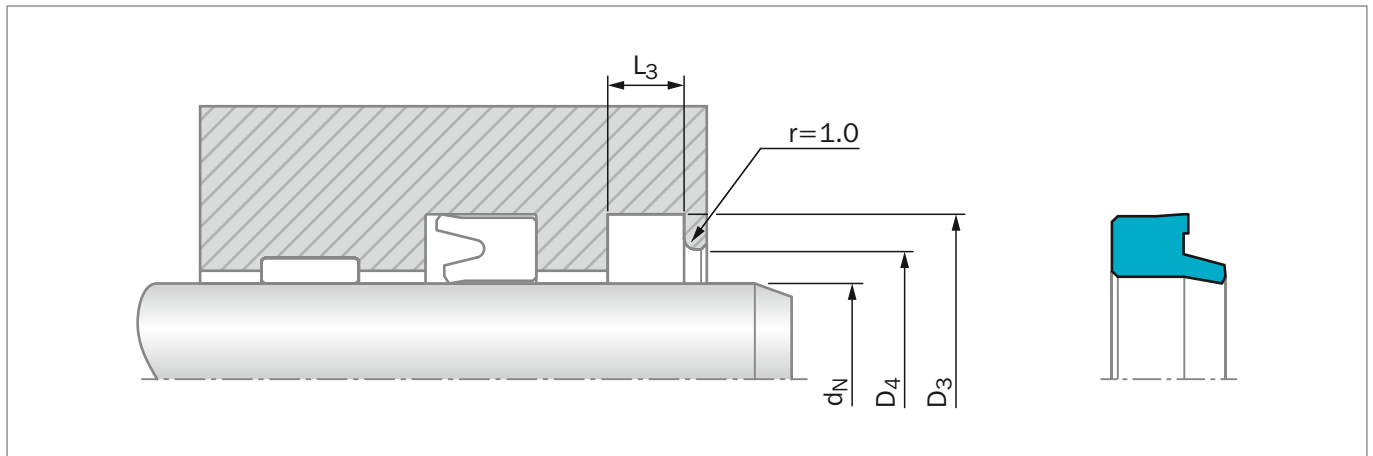

Figure 208: Installation Drawing

### ORDERING EXAMPLE

For WNE scrapers

<b>Rod Diameter:</b>	$d_N = 45 \text{ mm}$
<b>Groove Diameter:</b>	$D_3 = 53.6 \text{ mm}$
<b>TSS Part No.:</b>	WNE000450 from Table 190
<b>Material Code:</b>	Z201

<b>TSS Article No.</b>	<b>WNE0 0 0450 - Z201</b>
TSS Series No.	WNE0
Type (Standard)	0
Rod Diameter x 10	0450
Quality Index (Standard)	-
Material Code	Z201

Table 190: Installation Dimensions / TSS Part No.

Rod Diameter	Groove Diameter	Groove Width	Bore Diameter	TSS Part No.
$d_N$ h9	$D_3$ H11	$L_3$ +0.2	$D_4$ +0.2	
8.0	14.6	3.8	11.0	WNE000080
10.0	16.6	3.8	13.0	WNE000100
12.0	18.6	3.8	15.0	WNE000120
14.0	20.6	3.8	17.0	WNE000140
15.0	21.6	3.8	18.0	WNE000150
16.0	22.6	3.8	19.0	WNE000160
18.0	24.6	3.8	21.0	WNE000180
20.0	28.6	5.3	23.0	WNE000200
22.0	30.6	5.3	25.0	WNE000220
24.0	32.6	5.3	27.0	WNE000240
25.0	33.6	5.3	28.0	WNE000250
28.0	36.6	5.3	31.0	WNE000280
30.0	38.0	5.3	33.0	WNE000300
30.0	38.6	5.3	33.0	WNE100300



Rod Diameter	Groove Diameter	Groove Width	Bore Diameter	TSS Part No.
$d_N$ h9	$D_3$ H11	$L_3$ +0.2	$D_4$ +0.2	
32.0	40.6	5.3	35.0	WNE000320
35.0	43.0	5.3	38.0	WNE000350
35.0	43.6	5.3	38.0	WNE100350
36.0	44.6	5.3	39.0	WNE000360
38.0	46.6	5.3	41.0	WNE000380
40.0	48.6	5.3	43.0	WNE000400
45.0	53.6	5.3	48.0	WNE000450
46.0	54.6	5.3	49.0	WNE000460
50.0	58.6	5.3	53.0	WNE000500
50.0	58.0	5.3	53.0	WNE100500
55.0	63.6	5.3	58.0	WNE000550
56.0	64.6	5.3	59.0	WNE000560
60.0	68.6	5.3	63.0	WNE200600
61.0	69.6	5.3	64.0	WNE000610
63.0	71.6	5.3	66.0	WNE000630
65.0	73.6	5.3	68.0	WNE000650
70.0	78.6	5.3	73.0	WNE100700
75.0	83.6	5.3	78.0	WNE000750
80.0	88.6	5.3	83.0	WNE000800
85.0	97.2	7.1	91.0	WNE000850
90.0	102.2	7.1	96.0	WNE000900
95.0	107.2	7.1	101.0	WNE000950
100.0	112.2	7.1	106.0	WNE101000
110.0	122.2	7.1	116.0	WNE001100
120.0	132.0	7.1	126.0	WNE001200
125.0	137.2	7.1	131.0	WNE001250
135.0	147.2	7.1	141.0	WNE001350
140.0	152.2	7.1	146.0	WNE001400
160.0	175.2	10.1	168.0	WNE101600
180.0	195.2	10.1	188.0	WNE001800
200.0	215.2	10.1	208.0	WNE002000

---

! This page is intentionally left blank.

# Zurcon® Scraper WNV



---

Double-acting

---

**Material:**  
Zurcon®

---









## Zurcon® Scraper WNV



### Description

WNV is a double acting scraper in material Zurcon® polyurethane Z 201. The dynamic scraping lip is specially designed with an additional inwards sealing edge to keep the residual oil film in the system. If the volume of this oil film can not be backpumped by the main rod seal (e.g. u.cup) a pressure built up between u-cup and scraper will be prevented by releasing this pressure by lifting of the scraper lip.

The static sealing lip and edge respectively ensure against the intrusion of dirt and fluids (e.g. water) over the outer diameter of the scraper. The support on the reverse side of the scraper prevents it from twisting in the groove.

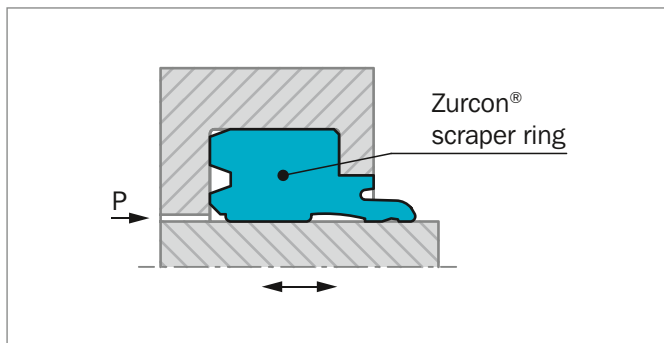

Figure 209: Scraper WNV

### ADVANTAGES

- Double acting
- Pressure release function
- Good static sealing performance due to additional seal lip at the housing
- Stable position of scraper in the housing
- Support bead with notches to support release function
- Housings in accordance to ISO 6195 type A

### APPLICATION EXAMPLES

- Mobile hydraulic machinery
- ISO-standard cylinders application
- Agriculture machinery
- Lift trucks
- Cargo tailboards
- Steering cylinders

### OPERATING CONDITIONS

<b>Speed:</b>	Up to 1 m/s
<b>Temperature:</b>	-35 °C to +100 °C
<b>Media:</b>	Mineral oil based hydraulic fluids
<b>Groove Type:</b>	Closed

### IMPORTANT NOTE

The above data are maximum values and cannot be used at the same time, e.g. the maximum operating speed depends on material type, pressure, temperature and gap value. Temperature range also depends on media.

### MATERIALS

Standard application:

Zurcon® Polyurethane: 92 Shore A

Material code: Z201

Color: turquoise



## ■ Installation Recommendation

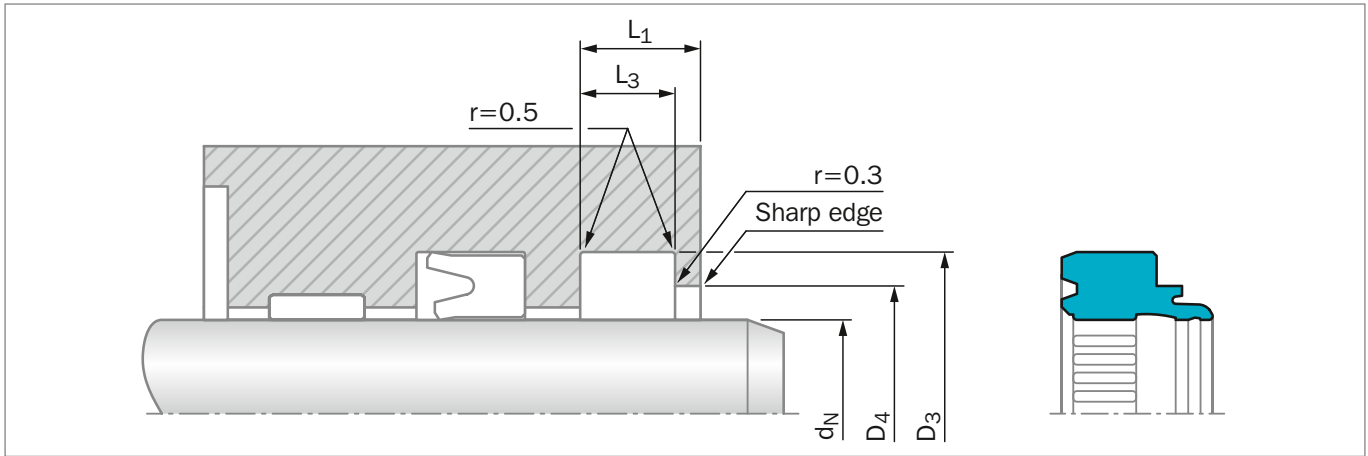

Figure 210: Installation Drawing

### ORDERING EXAMPLE

<b>Rod Diameter:</b>	$d_N = 45.0$ mm
<b>Groove Diameter:</b>	$D_3 = 53.0$ mm
<b>TSS Part No.:</b>	WNV000450 from Table 191
<b>Material Code:</b>	Z201

<b>TSS Article No.</b>	<b>WNV0 0 0450 - Z201</b>
TSS Series No.	WNV0
Type (Standard)	0
Rod Diameter x 10	0450
Quality Index (Standard)	-
Material Code	Z201

**Table 191: Installation Dimensions / TSS Part No.**

Rod Diameter	Groove Diameter	Bore Diameter	Groove Width	Depth	TSS Part No.
$d_N$	$D_3$	$D_4$	$L_3$	$L_1$	
h9	H8	H8	+0.2	+0.2	
16	24	21.5	5.0	7.0	WNV000160
18	26	23.5	5.0	7.0	WNV000180
20	28	25.5	5.0	7.0	WNV000200
25	33	30.5	5.0	7.0	WNV000250
30	38	35.5	5.0	7.0	WNV000300
32	40	37.5	5.0	7.0	WNV000320
35	43	40.5	5.0	7.0	WNV000350
40	48	45.5	5.0	7.0	WNV000400
45	53	50.5	5.0	7.0	WNV000450
50	58	55.5	5.0	7.0	WNV000500
60	68	65.5	5.0	7.0	WNV100600
70	80	77	6.3	8.3	WNV000700
80	90	87	6.3	8.3	WNV000800
100	115	110	9.5	12	WNV001000

# Scraper WSA



---

Single-acting

---

With Metal Case

---

For open Groove Assembly

---

**Material:**

NBR and Metal

---







## ■ Scraper WSA



### ■ Description

The scraper WSA is a mold-vulcanised single-acting elastomer scraper, with integral metal reinforcement for open groove assembly. In conjunction with the scraper oversize, an exact fit is obtained in the housing.

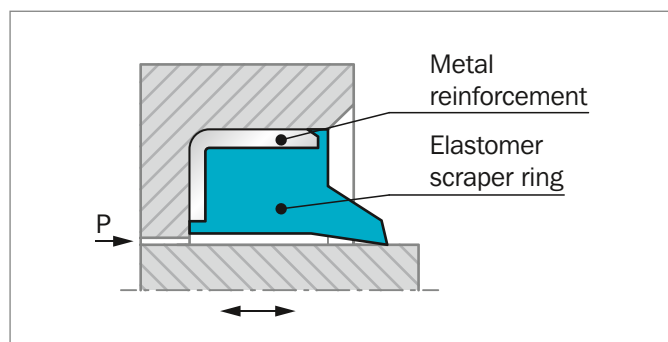

Figure 211: Scraper WSA

### ADVANTAGES

- Space-saving construction
- Low cost, economical solution
- Simple, easy-construction groove
- Firm fit in the groove due to metallic press fit

### APPLICATION EXAMPLES

- Hydraulic cylinders
- Agriculture machinery
- Construction machinery
- Lift trucks
- Mobile hydraulic

### OPERATING CONDITIONS

<b>Speed:</b>	Up to 1 m/s
<b>Temperature:</b>	-30 °C to +110 °C
<b>Media:</b>	Mineral oil based hydraulic fluids. polyglycol-water emulsions, water-oil emulsions
<b>Groove Type:</b>	Open

### IMPORTANT NOTE

The above data are maximum values and cannot be used at the same time, e.g. the maximum operating speed depends on material type, pressure, temperature and gap value. Temperature range also depends on media.

### MATERIALS

Standard application:

Material: NBR 90 Shore A + Metal

TSS code: N9MN



## ■ Installation Recommendation

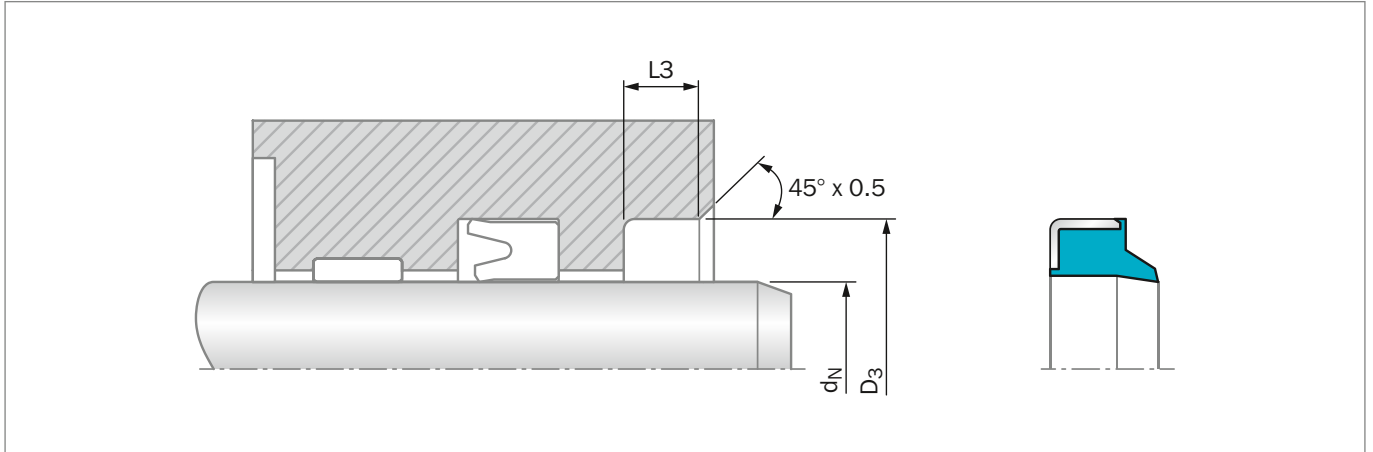

Figure 212: Installation Drawing

### ORDERING EXAMPLE

<b>Rod Diameter:</b>	$d_N = 35 \text{ mm}$
<b>Groove Diameter:</b>	$D_3 = 45 \text{ mm}$
<b>TSS Part No.:</b>	WSA000350 from Table 192
<b>Material Set-Code TSS:</b>	N9MN

<b>TSS Article No.</b>	<b>WSA0 0 0350 - N9MN</b>
TSS Series No.	WSA0
Type (Standard)	0
Rod Diameter x 10	0350
Quality Index (Standard)	-
Material Set-Code	N9MN

**Table 192: Installation Dimensions / TSS Part No.**

Rod Diameter	Groove Diameter	Groove Width	TSS Part No.
$d_N$ h9	$D_3$ H8	$L_3$ +0.2	
6.0	13.0	3.0	WSA000060
8.0	15.0	3.0	WSA000080
10.0	16.0	3.0	WSA000100
<b>10.0</b>	<b>18.0</b>	<b>5.0</b>	<b>WSA100100</b>
12.0	18.0	5.0	WSA200120
12.0	20.0	4.0	WSA000120
12.0	22.0	5.0	WSA100120
13.0	18.0	3.0	WSA000130
14.0	20.0	4.0	WSA100140
14.0	22.0	3.0	WSA000140
16.0	22.0	4.0	WSA000160
16.0	26.0	5.0	WSA200160
16.0	28.0	5.0	WSA300160
18.0	26.0	5.0	WSA000180



Rod Diameter	Groove Diameter	Groove Width	TSS Part No.
$d_N$ h9	$D_3$ H8	$L_3$ +0.2	
18.0	28.0	5.0	WSA300180
<b>18.0</b>	<b>28.0</b>	<b>7.0</b>	<b>WSA100180</b>
20.0	26.0	4.0	WSA000200
20.0	28.0	3.5	WSA200200
20.0	28.0	5.0	WSA300200
20.0	30.0	4.0	WSA400200
20.0	30.0	5.0	WSA500200
<b>20.0</b>	<b>30.0</b>	<b>7.0</b>	<b>WSA600200</b>
22.0	28.0	5.0	WSA000220
22.0	32.0	5.0	WSA200220
<b>22.0</b>	<b>32.0</b>	<b>7.0</b>	<b>WSA100220</b>
24.0	35.0	5.0	WSA000240
25.0	36.5	5.0	WSA200250
25.0	35.0	5.0	WSA000250
<b>25.0</b>	<b>35.0</b>	<b>7.0</b>	<b>WSA100250</b>
28.0	38.0	5.0	WSA000280
28.0	40.0	7.0	WSA100280
30.0	40.0	5.0	WSA000300
30.0	40.0	7.0	WSA100300
30.0	45.0	5.0	WSA200300
32.0	42.0	5.0	WSA000320
32.0	42.0	7.0	WSA400320
32.0	44.0	4.0	WSA300320
32.0	45.0	4.0	WSA100320
32.0	45.0	7.0	WSA200320
35.0	45.0	7.0	WSA000350
36.0	45.0	7.0	WSA000360
38.0	48.0	7.0	WSA000380
40.0	50.0	5.0	WSA100400
40.0	50.0	5.0	WSA000400
<b>40.0</b>	<b>50.0</b>	<b>7.0</b>	<b>WSA200400</b>
42.0	52.0	7.0	WSA000420
45.0	55.0	5.0	WSA100450
<b>45.0</b>	<b>55.0</b>	<b>7.0</b>	<b>WSA000450</b>
50.0	56.0	5.0	WSA000500
50.0	60.0	5.0	WSA200500
50.0	60.0	5.0	WSA500500
<b>50.0</b>	<b>60.0</b>	<b>7.0</b>	<b>WSA300500</b>
50.0	65.0	7.0	WSA400500
52.0	62.0	7.0	WSA000520
55.0	63.0	7.0	WSA000550
55.0	65.0	5.0	WSA200550



Rod Diameter	Groove Diameter	Groove Width	TSS Part No.
$d_N$ h9	$D_3$ H8	$L_3$ +0.2	
55.0	65.0	7.0	WSA100550
55.0	70.0	7.0	WSA300550
<b>56.0</b>	<b>66.0</b>	<b>7.0</b>	<b>WSA000560</b>
60.0	70.0	5.0	WSA200600
60.0	70.0	7.0	WSA000600
60.0	74.0	5.0	WSA100600
63.0	75.0	7.0	WSA000630
65.0	75.0	5.0	WSA100650
65.0	75.0	7.0	WSA000650
70.0	80.0	5.0	WSA100700
<b>70.0</b>	<b>80.0</b>	<b>7.0</b>	<b>WSA000700</b>
75.0	83.0	7.0	WSA100750
75.0	85.0	7.0	WSA000750
80.0	88.0	7.0	WSA100800
<b>80.0</b>	<b>90.0</b>	<b>7.0</b>	<b>WSA000800</b>
85.0	95.0	7.0	WSA000850
<b>90.0</b>	<b>100.0</b>	<b>7.0</b>	<b>WSA000900</b>
95.0	105.0	7.0	WSA000950
100.0	110.0	7.0	WSA001000
105.0	115.0	7.0	WSA001050
110.0	120.0	7.0	WSA001100
115.0	125.0	7.0	WSA001150
120.0	130.0	7.0	WSA001200
120.0	135.0	7.0	WSA101200
<b>125.0</b>	<b>140.0</b>	<b>9.0</b>	<b>WSA001250</b>
130.0	145.0	9.0	WSA001300
135.0	145.0	7.0	WSA001350
<b>140.0</b>	<b>155.0</b>	<b>9.0</b>	<b>WSA001400</b>
140.0	160.0	10.0	WSA101400
150.0	165.0	9.0	WSA001500
<b>160.0</b>	<b>175.0</b>	<b>9.0</b>	<b>WSA001600</b>
170.0	185.0	10.0	WSA001700
175.0	190.0	9.0	WSA001750
180.0	195.0	10.0	WSA001800
200.0	220.0	12.0	WSA002000
220.0	235.0	10.0	WSA002200
270.0	295.0	12.0	WSA002700

The sizes in **bold** type comply with ISO 6195, installation groove Type B. Other sizes on request.  
The listed products are technically equivalent but availability and pricing may vary.



# Zurcon® Scraper SWP



---

Single-acting

---

Metal Reinforcement

---

For open Groove Assembly

---

**Material:**

Zurcon® + Metal

---







## Zurcon® Scraper SWP



### Description

SWP are polyurethane manufactured lipped wipers with integrated metal reinforcement for open groove assembly. These are typically used in severe applications where there is abrasion due to solid matter on rod surface.

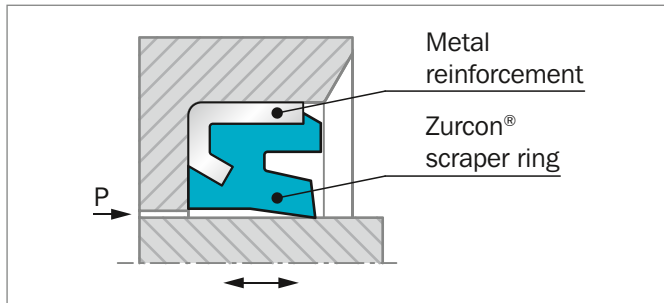

Figure 213: Scraper SWP

### ADVANTAGES

- Space-saving construction
- Simple small installation groove
- Firm fit in the groove due to metallic press fit
- At regreasing of drag bearing, the scraper lip opens at low overpressure; old grease can escape
- High wear resistance

### APPLICATION EXAMPLES

Due to their outstanding wiping capacities SWP scrapers are recommended wherever there are dusty and humid conditions and especially for the following applications:

- Mobile hydraulic machinery
- Construction machinery
- Link pin seals
- Lift trucks
- Truck cargo cranes
- Agriculture machinery

### OPERATING CONDITIONS

<b>Speed:</b>	Up to 1 m/s
<b>Temperature:</b>	-35 °C to +100 °C
<b>Media:</b>	Mineral oil based hydraulic fluids
<b>Groove Type:</b>	Open

### IMPORTANT NOTE

The above data are maximum values and cannot be used at the same time, e.g. the maximum operating speed depends on material type, pressure, temperature and gap value. Temperature range also depends on media.

### MATERIALS

Standard application

Zurcon® Polyurethane:	92 Shore A
Color:	turquoise
Metal case:	non alloyed steel DIN 1624
Material Set-Code:	Z2022



## ■ Installation Recommendation

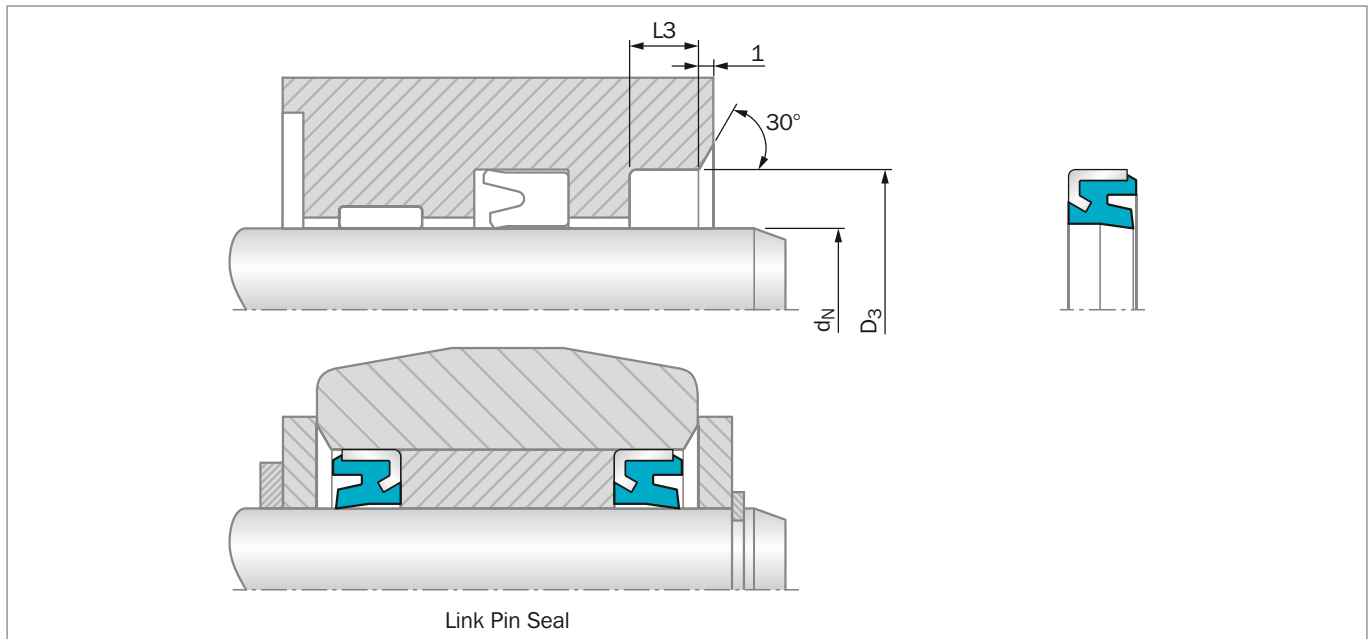

Figure 214: Installation Drawing

### ORDERING EXAMPLE

<b>Rod Diameter:</b>	$d_N = 40 \text{ mm}$
<b>Groove Diameter:</b>	$D_3 = 50 \text{ mm}$
<b>TSS Part No.:</b>	WSP000400 from Table 193
<b>Material Set-Code:</b>	Z2022 (standard)
<b>Polypac Ref.:</b>	SWP 4050

**TSS Article No.**      **WSP0 0 0400 - Z2022**

TSS Series No. \_\_\_\_\_

Type (Standard) \_\_\_\_\_

Rod Diameter x 10 \_\_\_\_\_

Quality Index (Standard) \_\_\_\_\_

Material Set-Code \_\_\_\_\_

**Table 193: Installation Dimensions / TSS Part Numbers**

Rod Diameter	Groove Diameter	Groove Width	TSS Part No.	Description
$d_N$ h9	$D_3$ H8	<b>L3</b> +0.2		
25.0	38.0	7.5	WSP000250	SWP2538
30.0	40.0	4.0	WSP000300	*SWP3040
35.0	50.0	7.5	WSP100350	SWP3550
36.0	48.0	6.0	WSP000360	SWP3648
40.0	50.0	4.0	WSP000400	*SWP4050
40.0	52.0	6.0	WSP100400	SWP4052
45.0	55.0	3.2	WSP000450	*SWP4555/1
45.0	55.0	4.0	WSP100450	*SWP4555
45.0	60.0	7.5	WSP200450	SWP4560



Rod Diameter	Groove Diameter	Groove Width	TSS Part No.	Description
$d_N$ h9	$D_3$ H8	$L_3$ +0.2		
50.0	60.0	4.0	WSP000500	*SWP5060
50.0	63.0	4.0	WSP100500	*SWP5063
50.0	65.0	7.5	WSP200500	SWP5065
55.0	65.0	3.2	WSP000550	*SWP5565
55.0	68.0	4.0	WSP100550	*SWP5568
56.0	70.0	7.5	WSP000560	SWP5670
60.0	75.0	4.0	WSP000600	*SWP6075/1
60.0	75.0	7.5	WSP100600	SWP6075
63.0	78.0	7.5	WSP000630	SWP6378
65.0	80.0	5.0	WSP000650	*SWP6580/1
65.0	80.0	7.5	WSP100650	SWP6580
70.0	80.0	5.0	WSP000700	*SWP7080
70.0	84.0	8.0	WSP100700	SWP7084
70.0	85.0	4.0	WSP200700	SWP7085/1
70.0	85.0	7.5	WSP300700	SWP7085
75.0	90.0	7.5	WSP000750	SWP7590
75.0	95.0	10.0	WSP100750	SWP7595
80.0	95.0	5.0	WSP000800	*SWP8095/1
80.0	95.0	7.5	WSP100800	SWP8095
80.0	100.0	10.0	WSP200800	SWP80100
85.0	100.0	4.0	WSP000850	*SWP85100/1
85.0	100.0	10.0	WSP100850	SWP85100
85.0	105.0	10.0	WSP200850	SWP85105
90.0	104.0	8.0	WSP000900	SWP90104
90.0	105.0	6.0	WSP100900	*SWP90105
90.0	110.0	10.0	WSP200900	SWP90110
95.0	115.0	10.0	WSP000950	SWP95115
99.0	115.0	7.5	WSP000990	SWP99115
100.0	115.0	4.0	WSP001000	*SWP100115/2
100.0	115.0	7.5	WSP201000	SWP100115
100.0	120.0	10.0	WSP301000	SWP100120
110.0	125.0	4.0	WSP001100	SWP110125/1
110.0	125.0	9.0	WSP101100	SWP110125
110.0	130.0	10.0	WSP201100	SWP110130
115.0	130.0	9.0	WSP101150	SWP115130/1
120.0	140.0	10.0	WSP001200	SWP120140
130.0	145.0	7.5	WSP001300	SWP130145
160.0	175.0	10.0	WSP001600	SWP160175
190.0	210.0	10.0	WSP001900	SWP190210

\* Can be used for "Link Pin Seal"

---

! This page is intentionally left blank.

# Metal Scraper



---

Single-acting

---

Metal and Elastomer Scrapers Lips

**Material:**

NBR, Metal and Brass

---









## ■ Metal Scraper



### ■ Description

The metal scraper is a single-acting special scraper with two different scraper lips - a thin metallic lip and an elastomer lip. The two scraper lips are arranged in tandem behind one another in a compact metal housing.

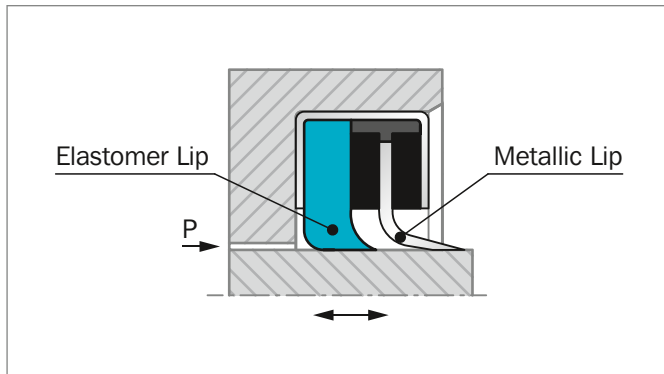

Figure 215: Metal Scraper

The metal scraper lip is designed to remove firmly adhering soiling and ice particles. The secondary lip of elastomer material enhances the overall scraping effect, i.e. fine sand grains, water and similar foreign matter are reliably scraped off. Both scraper lips have a smaller diameter than the nominal diameter of the piston rod, thus ensuring a tight fit of the scraper lips. The metallic lip is guided flexibly in radial direction and can easily follow any possible deflections of the piston rod.

### ADVANTAGES

- Very good scraping effect, even with firmly adhering dirt, e.g. mud, ice
- Very abrasion resistant
- Tight fit in the groove due to the metal case
- Easy installation in open grooves

### OPERATING CONDITIONS

<b>Speed:</b>	Max. 1 m/s with reciprocating movements
<b>Temperature:</b>	-30 °C to +110 °C
<b>Media:</b>	Mineral oil-based hydraulic fluids, flame retardant hydraulic fluids (HFA, HFB, HFC), water, air, etc.

### IMPORTANT NOTE

The above data are maximum values and cannot be used at the same time, e.g. the maximum operating speed depends on material type, pressure, temperature and gap value. Temperature range also depends on media.

### MATERIALS

Inner scraper lip:	Acrylonitrile butadiene rubber, NBR 70 Shore A Code N7
Metal housing:	Sheet metal 1.0204 (AISI 1008) or similar Code M
Outer scraper lip:	Brass Code S

Other materials for scraper lips and housing available on request. Also available in an imperial (inch) size range.



## ■ Installation Recommendation

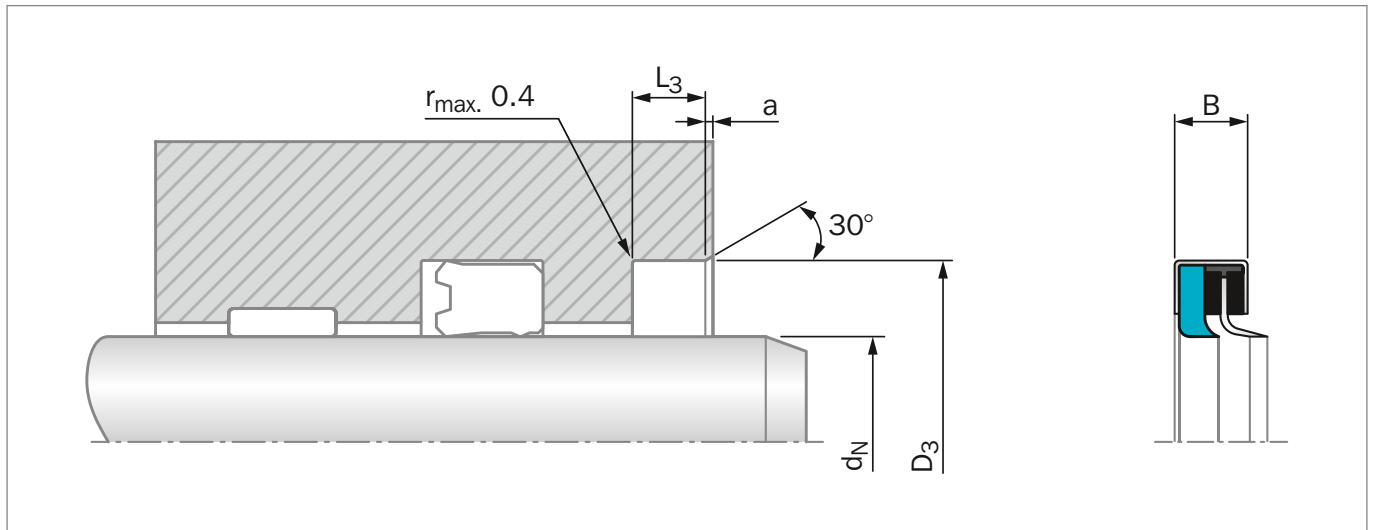

Figure 216: Installation Drawing

### ORDERING EXAMPLE

Metal Scraper

<b>Rod Diameter:</b>	$d_N = 80.00$ mm
<b>Groove Diameter:</b>	$D_3 = 96.00$ mm
<b>Groove Width:</b>	$L_3 = 8.50$ mm
<b>TSS Part No.:</b>	WM0100800 from Table 194
<b>Material:</b>	Standard materials Material code N7MS

<b>TSS Article No.</b>	<b>WM01</b>	<b>00800</b>	<b>-</b>	<b>N7</b>	<b>M</b>	<b>S</b>
TSS Series No.	_____	_____	_____	_____	_____	_____
Rod Diameter x 10	_____	_____	_____	_____	_____	_____
Quality index (Standard)	_____	_____	_____	_____	_____	_____
Material Code (Inner Scraper Lip)	_____	_____	_____	_____	_____	_____
Material Code (Housing)	_____	_____	_____	_____	_____	_____
Material Code (Outer Scraper Lip)	_____	_____	_____	_____	_____	_____



Table 194: Installation Dimensions / TSS Part Numbers

Rod Diameter	Groove Diameter	Groove Width	Chamfer	Width	TSS Part No.
$d_N$ f8/h9	$D_3$ H8	$L_3$ +0.2	$a$ min.	$B$	
<b>12.0</b>	<b>25.0</b>	<b>7.0</b>	<b>2.0</b>	<b>6.5</b>	<b>WM0000120</b>
<b>14.0</b>	<b>27.0</b>	<b>7.0</b>	<b>2.0</b>	<b>6.5</b>	<b>WM0000140</b>
15.0	28.0	7.0	2.0	6.5	WM0000150
<b>16.0</b>	<b>29.0</b>	<b>7.0</b>	<b>2.0</b>	<b>6.5</b>	<b>WM0000160</b>
<b>18.0</b>	<b>31.0</b>	<b>7.0</b>	<b>2.0</b>	<b>6.5</b>	<b>WM0000180</b>
<b>20.0</b>	<b>33.0</b>	<b>7.0</b>	<b>2.0</b>	<b>6.5</b>	<b>WM0000200</b>
<b>22.0</b>	<b>35.0</b>	<b>7.0</b>	<b>2.0</b>	<b>6.5</b>	<b>WM0000220</b>
<b>25.0</b>	<b>38.0</b>	<b>7.0</b>	<b>2.0</b>	<b>6.5</b>	<b>WM0000250</b>
<b>28.0</b>	<b>41.0</b>	<b>7.0</b>	<b>2.0</b>	<b>6.5</b>	<b>WM0000280</b>
30.0	43.0	7.5	2.0	7.0	WM0000300
<b>32.0</b>	<b>45.0</b>	<b>7.5</b>	<b>2.0</b>	<b>7.0</b>	<b>WM0000320</b>
35.0	48.0	7.5	2.0	7.0	WM0000350
<b>36.0</b>	<b>49.0</b>	<b>7.5</b>	<b>2.0</b>	<b>7.0</b>	<b>WM0000360</b>
38.0	51.0	7.5	2.0	7.0	WM0000380
<b>40.0</b>	<b>53.0</b>	<b>7.5</b>	<b>2.0</b>	<b>7.0</b>	<b>WM0200400</b>
<b>45.0</b>	<b>58.0</b>	<b>7.5</b>	<b>2.0</b>	<b>7.0</b>	<b>WM0000450</b>
<b>50.0</b>	<b>64.0</b>	<b>8.0</b>	<b>2.0</b>	<b>7.5</b>	<b>WM0000500</b>
55.0	69.0	8.0	2.0	7.5	WM0000550
58.0	72.0	8.0	2.0	7.5	WM0000580
60.0	74.0	8.0	2.0	7.5	WM0000600
<b>63.0</b>	<b>77.0</b>	<b>8.0</b>	<b>2.0</b>	<b>7.5</b>	<b>WM0000630</b>
65.0	79.0	8.0	2.0	7.5	WM0000650
<b>70.0</b>	<b>84.0</b>	<b>8.0</b>	<b>2.0</b>	<b>7.5</b>	<b>WM0000700</b>
75.0	89.0	8.0	2.0	7.5	WM0000750
<b>80.0</b>	<b>96.0</b>	<b>8.5</b>	<b>2.0</b>	<b>8.0</b>	<b>WM0100800</b>
85.0	101.0	8.5	2.0	8.0	WM0000850
<b>90.0</b>	<b>106.0</b>	<b>8.5</b>	<b>2.0</b>	<b>8.0</b>	<b>WM0000900</b>
95.0	111.0	8.5	2.0	8.0	WM0000950
<b>100.0</b>	<b>120.0</b>	<b>9.0</b>	<b>3.0</b>	<b>8.5</b>	<b>WM0001000</b>
<b>110.0</b>	<b>130.0</b>	<b>9.0</b>	<b>3.0</b>	<b>8.5</b>	<b>WM0001100</b>
120.0	140.0	9.0	3.0	8.5	WM0001200
130.0	150.0	9.0	3.0	8.5	WM0001300
<b>140.0</b>	<b>160.0</b>	<b>9.0</b>	<b>3.0</b>	<b>8.5</b>	<b>WM0001400</b>
150.0	170.0	9.0	3.0	8.5	WM0101500
<b>160.0</b>	<b>180.0</b>	<b>9.0</b>	<b>3.0</b>	<b>8.5</b>	<b>WM0001600</b>
170.0	190.0	9.0	3.0	8.5	WM0001700
<b>180.0</b>	<b>200.0</b>	<b>12.0</b>	<b>3.0</b>	<b>10.0</b>	<b>WM0001800</b>
<b>200.0</b>	<b>230.0</b>	<b>12.0</b>	<b>3.0</b>	<b>10.0</b>	<b>WM0102000</b>
210.0	230.0	12.0	3.0	10.0	WM0002100
<b>220.0</b>	<b>250.0</b>	<b>12.0</b>	<b>3.0</b>	<b>10.0</b>	<b>WM0002200</b>

The rod diameters in **bold** type comply with the recommendations of ISO 3320.

Other sizes on request.

Inch sizes can be supplied.

---

! This page is intentionally left blank.

# Turcon® Variseal® M2S



---

Single-acting

---

Spring-energized plastic U-Cup

---

**Material:**

Turcon® and Zurcon®

---







## Turcon® Variseal® M2S



### Description

Turcon® Variseal® M2S is a single-acting seal consisting of a U-shaped jacket and a V-shaped corrosion resistant spring. Variseal® M2S has an asymmetric seal profile. The dynamic lip is optimized, offering long service life and a good scraping ability even in media with high viscosity.

Unlike other scrapers the Variseal® M2S offers a functional combination of scraper and seal in one.

The spring cavity can be filled with high temperature HiClean silicone to prevent contamination blocking the cavity.

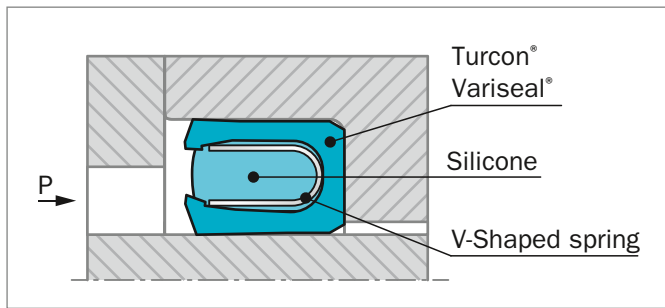

Figure 217: Turcon® Variseal® M2S

### AREAS OF APPLICATION

- Marine environments, able to scrape marine growth
- Subsea environments with high temperature application
- High speed hydraulics in dirty environments
- High temperature applications
- Low temperature and cryogenic applications
- Chemical plant where the lack of any elastomer is a benefit
- Food & Pharmaceutical application where the HiClean version has minimal entrapment areas and is resistant to many CIP/SIP fluids

### ADVANTAGES

- Suitable for reciprocating and light duty rotary movement
- Excellent scraping ability
- Combined scraping and sealing function
- High abrasion resistance
- Turcon has resistance to most fluids and chemicals
- Excellent resistance to aging
- Available for diameters from 3 to 3,200 mm
- Dimensionally stable
- Outstanding sliding and stick-slip properties

### OPERATING CONDITIONS

<b>Pressure:</b>	Maximum dynamic load:	20 MPa
	Maximum static load:	40 MPa (207 MPa with customs designs)
<b>Speed:</b>	Reciprocating	up to 15 m/s in T40 up to 2 m/s in Z80
	Rotating	up to 1.27 m/s in T40
<b>Temperature:</b>		-50 °C to +260 °C in T40
		-45 °C to +260 °C in T40 with HiClean
		-50 °C to +80 °C in Z80
		-196 °C custom design option available
<b>Media:</b>	Fluids of medium to high viscosity or containing hard particles	

### IMPORTANT NOTE

The above data are maximum values and cannot be used at the same time. e.g. the maximum operating speed depends on material type, pressure, temperature and gap value. Temperature range also depends on media.



## MATERIALS

All materials used are physiologically safe. They contain no odour or taste-affecting substances.

The following material combination has proved effective for most fluid applications:

Seal ring: Turcon® T40

Spring: Stainless steel, Material No. AISI 301  
Material code S

For gas applications use:

Seal ring: Zurcon® Z80

For use in accordance with the demands of the Food and Drug Administration, suitable materials are available on request.



**Table 195: Turcon® and Zurcon® Materials for Variseal® M2S**

Material Code Material Description	Operating Temperature* °C	Mating Surface Material	MPa max.
<b>Turcon® T40</b> High-grade formulation of virgin polytetrafluoroethylene (PTFE) based material compounded with carbon fiber additive. Excellent wear and low friction characteristics. Suited to reciprocating and rotary applications. Suitable for use in media with poor lubricating properties and for dry-running situations. Color: Black / gray	-60 to +300	Steel, hardened Steel, chromeplated	40
<b>Zurcon® Z80</b> UHMW Polyethylene. Excellent wear and abrasion resistance. Very good lubricity in water based media. Color: Translucent white	-253 to +80	Steel Steel, chromeplated Stainless steel Aluminum Bronze Ceramic coating	40

## SPRING MATERIALS

The standard spring material for Turcon® Variseal® is stainless steel (spring code S). Two further materials are available for the specific applications, as detailed in the table below.

**Table 196: Spring Material**

Media	Spring Materials	Spring Order Code
<b>For General use e.g.</b> Oil Grease Air Water, steam Solvents Food, drugs Gas	<b>Stainless steel</b> DIN Mat No. 1.4310/1.4319 AISI 301/302 UNS 30100	S (Standard spring material)
<b>For use in corrosive media e.g.</b> Acids Caustics Seawater	<b>Hastelloy® C-276</b> DIN Mat No. 2.4819 UNS N10276	H
For petrochemical use e.g. Crude oil Sour gas	<b>Elgiloy® 1)</b> DIN Mat No. 2.4711 UNSR30003	E

Hastelloy® is a registered trademark of Haynes International, Inc.

Elgiloy® is a registered trademark of the Elgiloy Specialty Metals.

Alternative brand may be used.

1) NACE-approval



## Groove Design

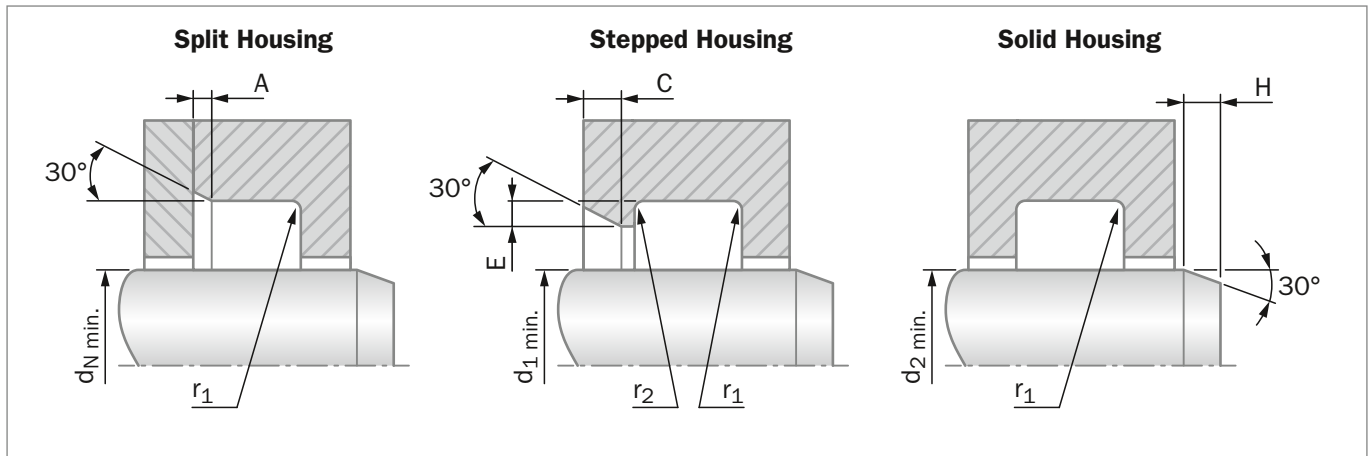

Figure 218: Variseal Groove Configurations

Installation lead-in chamfers and steps to include blend radii and are to be polished.

Table 197: Dimensions for Groove Designs

Series	Rod Groove Dimensions					
	A Chamfer	r <sub>1</sub> Maximum Radius	C Minimum Chamfer	r <sub>2</sub> Maximum Radius	E Minimum Step Height	H Minimum Chamfer
000	0.25 / 0.38	0.25	0.70	0.13	0.40	1.20
100	0.38 / 0.51	0.38	1.10	0.13	0.60	1.50
200	0.38 / 0.51	0.38	1.25	0.18	0.70	2.50
300	0.51 / 0.69	0.38	1.40	0.25	0.80	4.50
400	0.51 / 0.69	0.51	1.60	0.25	0.90	6.00
500	0.76 / 1.02	0.51	2.60	0.38	1.50	11.00

Table 198: Groove Design for Rod

Series	Rod Diameter Recommendations		
	Split Groove Ø d <sub>N</sub> Minimum	Stepped Groove Ø d <sub>1</sub> Minimum	Solid Groove Ø d <sub>2</sub> Minimum
000	3.00	20.00	31.75
100	6.00	30.00	69.85
200	10.00	35.00	111.13
300	20.00	40.00	298.45
400	35.00	45.00	495.30
500	80.00	80.00	762.00



## Installation Recommendation

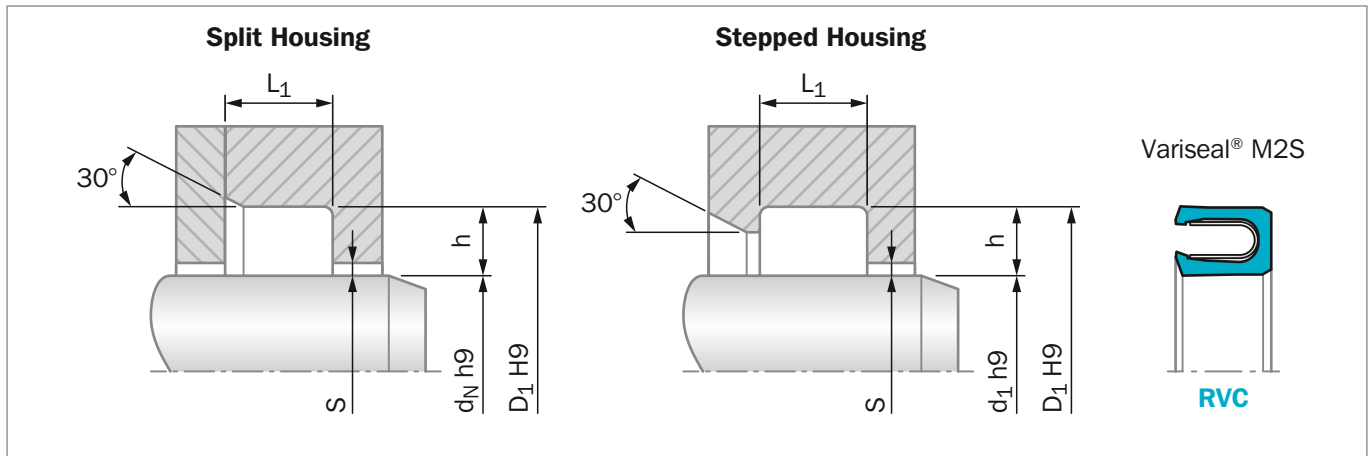

Figure 219: Installation Drawing

Table 199: Installation Dimensions

Series No.	Rod Diameter $d_N / d_1$ H9		Groove Depth $h$	Groove Diameter $D_1$ H9	Groove Width $L_1$ +0.2	Radial Clearance $S_{max.}$			
	Standard Range	Extended Range				2 MPa	10 MPa	20 MPa	40 MPa
RVC0	3 - 9.9	3 - 40	1.45	$d_N / d_1 + 2.9$	2.4	0.20	0.10	0.08	0.05
RVC1	10 - 19.9	6 - 200	2.25	$d_N / d_1 + 4.5$	3.6	0.25	0.15	0.10	0.07
RVC2	20 - 39.9	10 - 400	3.10	$d_N / d_1 + 6.2$	4.8	0.35	0.20	0.15	0.08
RVC3	40 - 119.9	20 - 700	4.70	$d_N / d_1 + 9.4$	7.1	0.50	0.25	0.20	0.10
RVC4	120 - 999.9	35 - 1,600	6.10	$d_N / d_1 + 12.2$	9.5	0.60	0.30	0.25	0.12
RVC5	1,000 - 2,500	80 - 2,500	9.50	$d_N / d_1 + 19.0$	15.0	0.90	0.50	0.40	0.20

### ORDERING EXAMPLE

Turcon® Variseal® M2S, recommended range:

<b>Series:</b>	RVC3 from Table 199
<b>Rod Diameter:</b>	$D_N = 80.0$ mm
<b>TSS Part No.:</b>	RVC300800 from Table 200
<b>Spring Material:</b>	Stainless steel from Table 196
<b>Spring Load:</b>	Medium

For other seal and spring materials please contact the Trelleborg Sealing Solutions representative.

**TSS Article No. RVC3 0 0800 - T40 S M**

TSS Series No.	RVC3
Type (Standard)	0
Rod Diameter x 10*	0800
Quality Index (Standard)	-
Material Code (Seal Ring)	T40
Material Code (Spring)	S
Spring Load (Medium)	M

\* For diameters  $\geq 1,000.0$  mm multiply only by factor 1.

Example: RVC5 for diameter 1,200.0 mm

TSS Article No.: RVC5**X1200** - T40SM

**Table 200: Installation Dimensions / TSS Part No.**

$d_N$	$D_1$	TSS Part No.	$d_N$	$D_1$	TSS Part No.	$d_N$	$D_1$	TSS Part No.
3.0	5.9	RVC0_0030	35.0	41.2	RVC2_0350	<b>90.0</b>	<b>99.4</b>	<b>RVC3_0900</b>
4.0	6.9	RVC0_0040	<b>36.0</b>	<b>42.2</b>	<b>RVC2_0360</b>	95.0	104.4	RVC3_0950
5.0	7.9	RVC0_0050	<b>40.0</b>	<b>49.4</b>	<b>RVC3_0400</b>	<b>100.0</b>	<b>109.4</b>	<b>RVC3_1000</b>
6.0	8.9	RVC0_0060	42.0	51.4	RVC3_0420	105.0	114.4	RVC3_1050
8.0	10.9	RVC0_0080	<b>45.0</b>	<b>54.4</b>	<b>RVC3_0450</b>	<b>110.0</b>	<b>119.4</b>	<b>RVC3_1100</b>
10.0	14.5	RVC1_0100	48.0	57.4	RVC3_0480	115.0	124.4	RVC3_1150
12.0	16.5	RVC1_0120	<b>50.0</b>	<b>59.4</b>	<b>RVC3_0500</b>	120.0	132.2	RVC4_1200
14.0	18.5	RVC1_0140	52.0	61.4	RVC3_0520	<b>125.0</b>	<b>137.2</b>	<b>RVC4_1250</b>
15.0	19.5	RVC1_0150	55.0	64.4	RVC3_0550	130.0	142.2	RVC4_1300
16.0	20.5	RVC1_0160	<b>56.0</b>	<b>65.4</b>	<b>RVC3_0560</b>	135.0	147.2	RVC4_1350
18.0	22.5	RVC1_0180	60.0	69.4	RVC3_0600	<b>140.0</b>	<b>152.2</b>	<b>RVC4_1400</b>
20.0	26.2	RVC2_0200	<b>63.0</b>	<b>72.4</b>	<b>RVC3_0630</b>			
22.0	28.2	RVC2_0220	65.0	74.4	RVC3_0650			
25.0	31.2	RVC2_0250	<b>70.0</b>	<b>79.4</b>	<b>RVC3_0700</b>			
28.0	34.2	RVC2_0280	75.0	84.4	RVC3_0750			
30.0	36.2	RVC2_0300	<b>80.0</b>	<b>89.4</b>	<b>RVC3_0800</b>			
32.0	38.2	RVC2_0320	85.0	94.4	RVC3_0850			

Rod diameters in **bold** type correspond to the recommendations of ISO 3320.

For additional size and part number details please contact your local Trelleborg Sealing Solutions Marketing company.

# Additional Scrapers



---

Available upon Request

---

Old Series

---

Special Series

---







### POLYPAC® UWR/PC

The UWR/PC is double-acting polyurethane wiper with integrated metal reinforcement for open groove assembly. The double lip guarantees a reliable scraper effect in one side and the sealing function of the oil film on the other.

Diameter Range mm	Pressure Range MPa	Temperature Range °C	Velocity m/s
35 - 150	-	-35 to +100	Up to 0.5

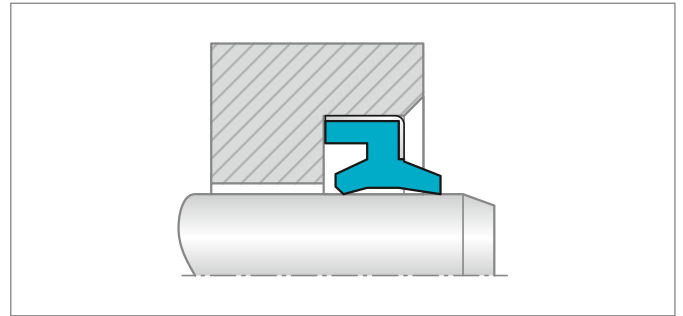

### TURCON® EXCLUDER® G

A double-acting scraper with two different scraper lips which are positioned back-to-back. The scraper is installed with two O-Rings as elastic energizing elements. It is used in medium to heavy-duty applications where a gap between the rod and the gland in front of the Excluder® is not wanted. Standard TSS Part Numbers are available (WEG).

Diameter Range mm	Pressure Range MPa	Temperature Range °C	Velocity m/s
100 - 999	-	-45 to +200	Up to 5

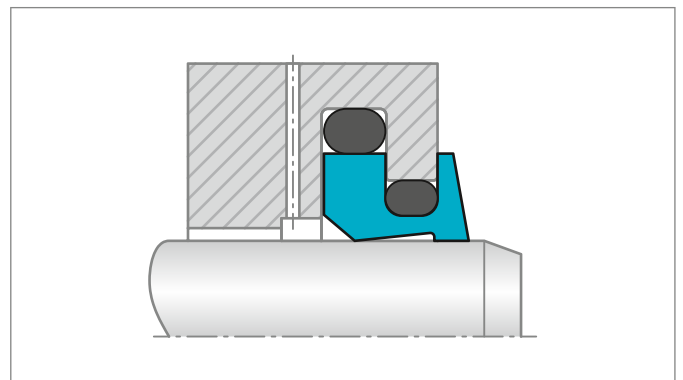

### SCRAPER DA27

The scraper DA27 is a moulded double-acting elastomer scraper. It has two geometrically different scraper lips. The scraper is preferably used for reciprocating piston rods and plunger pistons in large hydraulic cylinders. It prevents the penetration of dirt into the system and on the medium side holds back the residual oil film from the extending piston rod.

Diameter Range mm	Pressure Range MPa	Temperature Range °C	Velocity m/s
400 - 1,300	-	-30 to +100	Up to 1

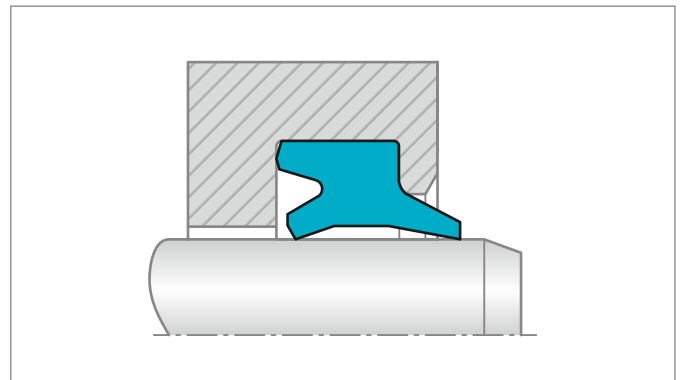

---

! This page is intentionally left blank.