

Pneumatic Seals

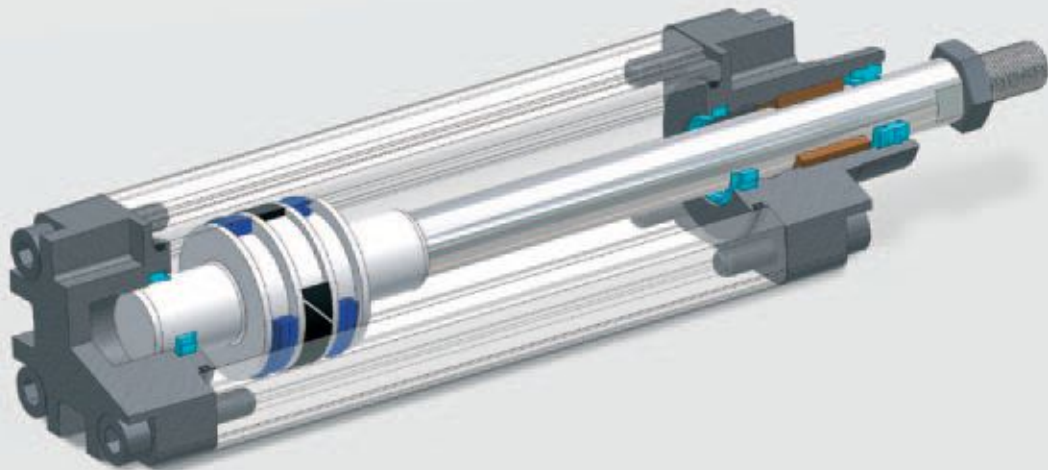



Your Partner for Sealing Technology

Trelleborg Sealing Solutions is a major international sealing force, uniquely placed to offer dedicated design and development from our market-leading product and material portfolio: a one-stop-shop providing the best in elastomer, thermoplastic, PTFE and composite technologies for applications in aerospace, industrial and automotive industries.

With 50 years of experience, Trelleborg Sealing Solutions engineers support customers with design, prototyping, production, test and installation using state-of-the-art design tools. An international network of over 70 facilities worldwide includes over 20 manufacturing sites, strategically-positioned research and development centers, including materials and development laboratories and locations specializing in design and applications.

Developing and formulating materials in-house, we utilize the resource of our material database, including over 2,000 proprietary compounds and a range of unique products.

Trelleborg Sealing Solutions fulfills challenging service requirements, supplying standard parts in volume or a single custom-manufactured component, through our integrated logistical support, which effectively delivers over 40,000 sealing products to customers worldwide.

Facilities are certified to ISO 9001:2008 and ISO/TS 16949:2009. Trelleborg Sealing Solutions is backed by the experiences and resources of one of the world's foremost experts in polymer technology: the Trelleborg Group.

ISO 9001:2008

ISO/TS 16949:2009

The information in this brochure is intended to be for general reference purposes only and is not intended to be a specific recommendation for any individual application. The application limits for pressure, temperature, speed and media given are maximum values determined in laboratory conditions. In application, due to the interaction of operating parameters, maximum values may not be achieved. It is vital therefore, that customers satisfy themselves as to the suitability of product and material for each of their individual applications. Any reliance on information is therefore at the user's own risk. In no event will Trelleborg Sealing Solutions be liable for any loss, damage, claim or expense directly or indirectly arising or resulting from the use of any information provided in this brochure. While every effort is made to ensure the accuracy of information contained herewith, Trelleborg Sealing Solutions cannot warrant the accuracy or completeness of information.

To obtain the best recommendation for a specific application, please contact your local Trelleborg Sealing Solutions marketing company.

This edition supersedes all previous brochures.
This brochure or any part of it may not be reproduced without permission.

© All trademarks are the property of Trelleborg Group.
The turquoise color is a registered trademark of Trelleborg Group.
© 2011, Trelleborg Group. All rights reserved.

Pneumatic Seals

Contents

	Page
General information	
Product range	3
Surface roughness	7
Materials	8
Part I Rod seals and piston seals	
Rod seal	10
Type ARUP	10
Type ARG	12
Piston seal	16
Type APDE	16
Type APDF	19
Type APDG	21
Type APDS	23
Type APMP	25
Type APG	28
Type AK	32
Part II Rod seal-scraper combinations	
Type ARS	34
Type AWNS	36
Type AWSD	39
Type ARAA	41
Type ARAN	42
Type AWSW (Scraper)	44
Type AWBB (Scraper)	48
Type ARV	50

Pneumatic Seals

Part III Cushioning seals

Type AICM	52
Type AIAS	54

Part IV Wear rings

Wear ring	56
Type GP	58
Type GR	61



Part V Static seals

Type DRV4	64
-----------------	----





Sealing solutions for Pneumatics

Table I Rod seals and piston seals

Rod seal

Seal		Application		Installation		Technical data*			Material
Type	Page	Field of application	Function	Ø Range mm	Groove type	Temperature* in °C	Speed m/s	Operating Pressure MPa	Standard seal material***
ARUP 	10	Industrial Pneumatics Standard Cylinders	single acting	3-110	closed	-40 to +80	1	1.6	PU WU9E1
ARG 	12	Pneumatic Special Cylinders	single and double acting	3-2600	closed	-30 to +80	5	5	Zurcon® Z80
						-30 to +200	5	5	Turcon® T19

Piston seal

Seal		Application		Installation		Technical data*			Material
Type	Page	Field of application	Function	Ø Range mm	Groove type	Temperature* in °C	Speed m/s	Operating Pressure MPa	Standard seal material***
APDE 	16	Industrial Pneumatics Standard Cylinders	single acting	4-250	closed	-40 to +80	1	1.6	PU WU9E1
APDF 	19	Industrial Pneumatics ISO/VDMA-Cylinders	single acting	25-125	closed	-35 to +85	1	1.6	PU Zurcon® Z30
APDG 	21	Industrial Pneumatics ISO/VDMA-Cylinders	single acting	32-100	closed	-35 to +85	1	1.6	PU Zurcon® Z30
APDS 	23	Industrial Pneumatics Standard Cylinders	single acting	6-100	closed	-40 to +80	1	1.6	PU WU9E1

Sealing solutions for Pneumatics







Seal		Application		Installation		Technical data*			Material
Type	Page	Field of application	Function	Ø Range mm	Groove type	Temperature* in °C	Speed m/s	Operating Pressure MPa	Standard seal material***
APMP 	25	Industrial Pneumatics Standard Cylinders	single acting	8-100	open	-40 to +80	1	1.6	PU WU9E1
APG 	28	Pneumatic Special Cylinders	single and double acting	6-2700	closed	-30 to +80	5	5	Zurcon® Z80
						-30 to +200	5	5	Turcon® T19
AK 	32	Industrial Pneumatics Standard Cylinders	double acting	25-200	open	-30 to +100	1	1.2	NBR N7MM

Table II Rod seal-scrapers combinations and scrapers

Seal		Application		Installation		Technical data*			Material
Type	Page	Field of application	Function	Ø Range mm	Groove type	Temperature* in °C	Speed m/s	Operating Pressure MPa	Standard seal material***
ARS 	34	Industrial Pneumatics High Temperature*- Cylinders	double acting	12-63	open	-15 to +150	1	1.6	FKM VC4VR
AWNS 	36	Industrial Pneumatics Standard Cylinders	double acting	3-70	closed	-40 to +80	1	1.6	PU WU9E1
AWSD 	39	Industrial Pneumatics Standard Cylinders	double acting	4-100	closed	-40 to +80	1	1.6	PU WU9E1
ARAA 	42	Industrial Pneumatics ISO/VDMA-Cylinders	double acting	12-32	open	-35 to +110	1	1.6	PU Zurcon® Z20

Sealing solutions for Pneumatics







Seal		Application		Installation		Technical data*			Material
Type	Page	Field of application	Function	Ø Range mm	Groove type	Temperature* in °C	Speed m/s	Operating Pressure MPa	Standard seal material***
ARAN 	44	Industrial Pneumatics Standard Cylinders	double acting	12-63	open	-40 to +80	1	1.6	PU WU9E1
AWSW 	46	Industrial Pneumatics Standard Cylinders	single acting	6-60	open	-40 to +80	1	-	PU WU9E1
AWBB 	48	Wipers For Guiding Units	single acting	6-50	open	-40 to +80	4	-	PU WU9E1
ARV 	50	Industrial Pneumatics Special Applications	double acting	10-25**	open	-70 to +80	5	1.6	Zurcon® Z80

Table III Cushioning seals

Seal		Application		Installation		Technical data*			Material
Type	Page	Field of application	Function	Ø Range mm	Groove type	Temperature* in °C	Speed m/s	Operating Pressure MPa	Standard seal material***
AICM 	52	Industrial Pneumatics ISO/VDMA-Cylinders	cushioning	6-57	closed	-35 to +110	1	1.6	PU Zurcon® Z20
AIAS 	54	Industrial Pneumatics Standard Cylinders	cushioning	10-50	closed	-40 to +80	1	1.6	PU WU9E1

Sealing solutions for Pneumatics

Table IV Wear rings



Seal		Application		Installation		Technical data*			Material
Type	Page	Field of application	Function	Ø Range mm	Groove type	Temperature* in °C	Speed m/s	Operating Pressure MPa	Standard seal material***
GP 	56	Industrial Pneumatics Standard Cylinders	piston wear ring	8-250	closed	-40 to +110	1	-	POTBW
GR 	61	Industrial Pneumatics Standard Cylinders	rod wear ring	8-50	closed	-40 to +110	1	-	POTBW

Table V Static seals

Seal		Application		Installation		Technical data*			Material
Type	Page	Field of application	Function	Ø Range mm	Groove type	Temperature* in °C	Speed m/s	Operating Pressure MPa	Standard seal material***
DRV4 	64	Fittings at valves, Cylinder and other Pneumatic Application	static seal	G1/8 - G3/4	no installation space required	-10 to +60	-	1.0	PA / TPU U8XPA

* Temperature information refers to material characteristics and may vary application use.

** Further dimensions on request.

*** Further materials possible.

Material Overview

■ Surface roughness DIN EN ISO 4287

The functional reliability and service life of a seal depend to a very great extent on the quality and surface finish of the mating surface to be sealed.

Scores, scratches, pores, concentric or spiral machining marks are not permitted. Higher demands must be made on the surface finish of dynamic surfaces than of static mating surfaces.

The characteristics most frequently used to describe the surface microfinish R_a , R_z and R_{max} are defined in DIN EN ISO 4287. These characteristics alone, however, are not sufficient for assessing the suitability in seal technology. In addition the material contact area of the surface roughness profile R_{mr} in accordance with DIN EN ISO 4287 should be demanded. The significance of this surface specification is illustrated in Fig. 1. It shows clearly that specification of R_a and R_z alone does not describe the surface roughness profile accurately enough for the seal technology and is thus not sufficient for assessing the suitability. The material contact area R_{mr} is essential for assessing surfaces, as this parameter is determined by the specific surface roughness profile. This in turn is directly dependent on the machining process employed.

Trelleborg Sealing Solutions recommends that the following surface finishes be observed:

Table VI Surface roughness

Surface roughness μm		
Parameter	Mating surface	Groove surface
R_{max}	1.0 - 4.0	< 16.0
R_z DIN	0.63 - 2.50	< 10.0
R_a	0.10 - 0.60	< 1.6

The material contact area R_{mr} should be approx. 50 to 70%, determined at a cut depth $c = 0.25 \times R_z$, relative to a reference line of C_{ref} 5%.



Surface profile	R_a	R_z	R_{mr}
closed profile form 	0.1	1.0	70%
open profile form 	0.2	1.0	15%

Figure 1 Profile forms of surfaces

Figure 1 shows two surface profiles, both of which exhibit nearly the same value for R_z in the test procedure. The difference becomes obvious only when the material contact area of the surface roughness profiles are compared. These show that the upper roughness profile with $R_{mr} = 70\%$ has the better seal/mating surface ratio.

Material Overview

■ Characteristics of new Zurcon® high-performance polyurethane materials

The general advantage of polyurethane materials compared with elastomer materials is based on an enormous durability a high breaking elongation and excellence elasticity.

Due to this engineers can expect high wear resistance, outstanding tear resistance and unmatched abrasion resistance even in operation with oilfree compressed air.

Table VII

	Material	Hardness	Temperature	Colour	Suitable for
Zurcon® Z20	High performance material	94 Shore A	- 35 °C to + 110 °C (short term + 130 °C)	turquoise	Rod Seals, Scrapers, e.g. ARAA, O-Rings, Cushioning Seals
Zurcon® Z22	Premium low temperature material	94 Shore A	- 45 °C to + 110 °C (short term + 130 °C)	dark turquoise	Rod Seals, Scrapers, e.g. ARAA, O-Rings
Zurcon® Z24	Special material with enhanced hydrolysis resistance	94 Shore A	- 30 °C to + 110 °C (short term + 130 °C)	green	Rod Seals, Scrapers, e.g. ARAA, O-Rings
Zurcon® Z30	High performance material	83 Shore A	- 35 °C to + 85 °C (short term + 100 °C)	grey-blue	Piston Seals, e.g. APDF, APDG, O-Rings
Zurcon® Z32	Special material with improved low temperature properties an enhanced hydrolysis resistance	83 Shore A	< - 50 °C to + 85 °C (short term + 100 °C)	cobalt blue	Piston Seals, e.g. APDF, APDG, O-Rings

Exceeding set temperature limits is possible for short periods of time with 94 Shore A materials up to + 130°C and with 83 Shore A materials up to + 100°C.

For special applications that are outside the above listed ranges please contact TSS polyurethane development department.

■ Characteristics of WU9E1 material

Standard polyurethane with fair performance level.

Table VIII

	Material	Hardness	Temperature	Colour	Suitable for
WU9E1	Standard polyurethane	90 Shore A	- 40 °C to + 80 °C	grey	Piston Seals, Rod Seals, Scrapers, Cushioning Seals

■ Characteristics of FKM - materials

Elastomeric material for pneumatic applications at high temperature. Very good thermosetting behaviour and resistance to ozone and ageing.

Table IX

	Material	Hardness	Temperature	Colour	Suitable for
VC4VR	FKM/metall combination (seal) + stainless steel (circlip)	75 Shore A	- 15 °C to + 150 °C (short term + 200 °C)	brown	Rod Seal, Scrapers

Material Overview

■ Characteristics of Turcon® materials

Turcon® is a particular PTFE material for special pneumatic applications where great importance e.g. is

attached to no stick-slip effect, minimum static and dynamic friction coefficient and high wear resistance.

Table X

Material		Hardness	Temperature	Colour	Suitable for
Turcon® T19	High grade composition of PTFE resin with mineral fibre intensifier.	62 Shore D	- 50 °C to + 200 °C	dark green-grey	Double acting Glyd Ring® APG / ARG
Turcon® T24	High grade composition of PTFE resin with carbon additives.	62 Shore D	- 50 °C to + 200 °C	black	Double acting Glyd Ring® APG / ARG

■ Characteristics of Zurcon® Z80 - material

Special Polyethylene grade with ultra high molecular weight. High abrasion resistance even under poor lubrication conditions. Very good chemical resistance.

Suitable for contact with foodstuff (FDA compliant). Limited elasticity, therefore always used together with elastic energizer elements.

Table XI

Material		Hardness	Temperature	Colour	Suitable for
Zurcon® Z80	UHMWPE (ultra high molecular weight polyethylene)	52 Shore D	- 30 °C to + 80 °C (other temperature ranges on request)	white to off-white	Rod Seals, Piston Seals, Double acting Glyd Ring® APG / ARG

■ Different materials

Table XII

Material		Hardness	Temperature	Colour	Suitable for
N7MM	NBR/metal combination	70 Shore A	- 30 °C to + 100 °C	black	Complete Piston
N7083	NBR	70 Shore A	- 30 °C to + 100 °C	black	O-Ring energizer
V70GA	FKM	70 Shore A	- 10 °C to + 200 °C	green	O-Ring energizer
U8XPA	PA / TPU	80 Shore A	- 10 °C to + 60 °C	grey / black	Composite Seal

■ Recommendations

Lubricant information: Up to +80° C conventional lubricants for pneumatic applications are approved for

use. When using the seals within other temperature ranges please contact TSS before.



Rod Seal - Type ARUP

■ Rod seal type ARUP

Description

Single acting rod seal with U-shaped cross-section. Special lip design for pneumatic application to maintain lubricating film and minimize friction.

Technical data

Operating pressure: 1.6 MPa

Speed: ≤ 1 m/s

Temperature: from -40 °C to +80 °C

Media: oil free air (initial grease lubrication required), lubricated air, nonaggressive gases

Material

Standard polyurethane with fair performance level.

Standard Material: Polyurethane, 90 Shore A, Material No.: WU9E1

Installation

Installation into split grooves or in closed grooves (above rod diameter 16). It is important to remove all sharp edges and burrs from the groove and rod before installation.

Ordering example

Rod Seal,
type ARUP

Rod diameter: d = 50 mm

Groove width: L = 7.5 mm

TSS Part No.: ARUP00500 (Table XIII)

Material No.: WU9E1

TSS Article No.	ARUP0	0500	-	WU9E1
TSS Series No.				
Rod diameter x 10				
Material Code				



Installation recommendation, type ARUP

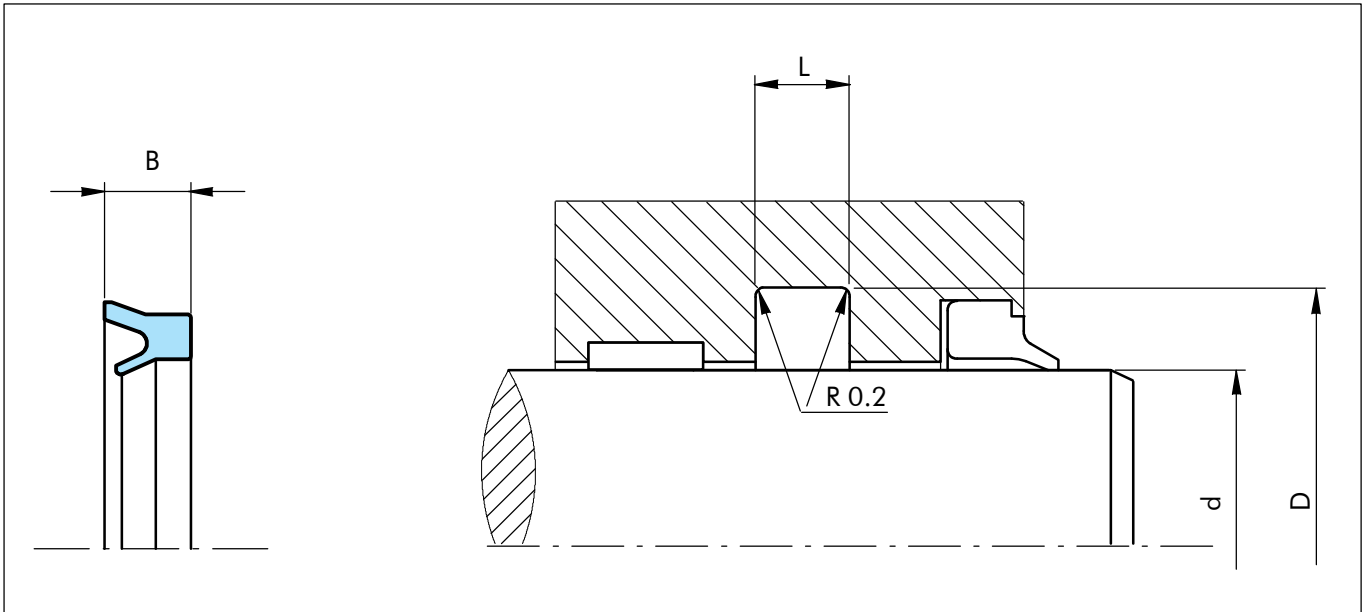

Figure 2 Installation drawing

Table XIII Installation dimensions / TSS Part No.

Rod diam.	Groove diam.	Groove width	Ring width	TSS Part No.
d f7	D H9	L +0.5	B	
3.0	6.0	3.0	2.5	ARUP00030
4.0	8.0	3.5	3.0	ARUP00040
5.0	9.0	3.0	2.5	ARUP00050
6.0	10.0	3.5	3.0	ARUP00060
6.0	11.0	3.5	3.0	ARUP10060
6.0	12.0	4.5	4.0	ARUP20060
7.0	13.0	4.5	4.0	ARUP00070
8.0	14.0	4.5	4.0	ARUP10080
8.0	14.0	5.0	4.5	ARUP00080
10.0	16.0	5.0	4.5	ARUP00100
10.0	18.0	6.0	5.5	ARUP10100
12.0	20.0	6.0	5.5	ARUP00120
14.0	22.0	6.0	5.5	ARUP00140
16.0	24.0	6.0	5.5	ARUP00160
18.0	26.0	6.0	5.5	ARUP00180
20.0	28.0	6.0	5.5	ARUP00200
22.0	28.0	5.0	4.3	ARUP10220
22.0	30.0	6.0	5.5	ARUP00220
25.0	33.0	6.0	5.5	ARUP00250
28.0	36.0	6.0	5.5	ARUP00280
28.0	38.0	7.5	7.0	ARUP10280
30.0	38.0	6.0	5.5	ARUP00300
30.0	40.0	7.5	7.0	ARUP10300
32.0	40.0	6.0	5.5	ARUP00320

Rod diam.	Groove diam.	Groove width	Ring width	TSS Part No.
d f7	D H9	L +0.5	B	
35.0	43.0	8.5	8.0	ARUP00350
35.0	45.0	7.5	7.0	ARUP10350
36.0	46.0	7.5	7.0	ARUP00360
40.0	48.0	6.0	5.5	ARUP00400
40.0	50.0	7.5	7.0	ARUP10400
45.0	55.0	7.5	7.0	ARUP00450
50.0	60.0	7.5	7.0	ARUP00500
55.0	65.0	7.5	7.0	ARUP00550
56.0	66.0	7.5	7.0	ARUP00560
60.0	72.0	9.5	8.5	ARUP00600
63.0	73.0	7.5	7.0	ARUP00630
63.0	75.0	9.5	8.5	ARUP10630
65.0	77.0	9.5	8.5	ARUP00650
70.0	82.0	9.5	8.5	ARUP00700
75.0	87.0	9.5	8.5	ARUP00750
80.0	92.0	9.5	8.5	ARUP00800
85.0	97.0	9.5	8.5	ARUP00850
90.0	102.0	9.5	8.5	ARUP00900
95.0	107.0	9.5	8.5	ARUP00950
100.0	115.0	11.0	10.0	ARUP01000
110.0	125.0	11.0	10.0	ARUP01100



Rod seal - Type ARG

■ Rod seal type ARG

Description

Double acting Glyd Ring® rod seal comprising a slipper seal and an energising O-Ring. Specially designed for low friction pneumatic applications with small installation space. Available for all diameters from 3 to 2600 mm.

Technical data

- Operating pressure: 1.6 MPa (max. 5 MPa)
- Speed: <=5 m/s
- Temperature*: -30 °C ... +200 °C (other temperature ranges on request)
- Media: oil free air (initial grease lubrication recommended), lubricated air, nonaggressive gases - depending on the O-Ring material compatibility.

Material

- Standard Material: Zurcon® Z80, ultra-high-molecular weight-polyethylen, 61 Shore D, colour white to off-white. Maximum temperature: 80 °C Material No.: Z80N or Z80V *
- Alternative: Turcon® T19, high grade composition of PTFE resin with mineral fibre intensifier, 62 Shore D, colour dark green-grey. Maximum temperature: 200 °C Material No.: T19N or T19V *

* depends on O-Ring material (N=NBR / V=FKM)

- O-Ring material: N7083 NBR 70 Shore A (-30 °C ... +100 °C)
V70GA FKM 70 Shore A (-10 °C ... +200 °C)

Installation

Installation into split grooves or closed grooves (above rod diameter 12 mm). Direct O-Ring groove installation followed by Glyd Ring® installation (note: Glyd Ring® to be deformed into kidney shape and placed into groove where Glyd Ring® reassumes original round shape.) It is important to remove all burrs and sharp edges from the groove and rod before installation.

Ordering example

Turcon® Glyd Ring® ARG complete with O-Ring. Standard application. Series ARG from Table XIV. Rod diameter: d_N = 80 mm TSS Part No.: ARG300800 from Table XVI

Select the material from Table I The corresponding material code numbers are appended to the TSS Part No. from Table XVI. Together they form the TSS Article No.

Other dimensions and all intermediate sizes up to 999.9 mm diameter can be supplied. For rod diameters > 999.9 mm and up to 2.600 mm use the RG45 series Turcon® Glyd Ring® .

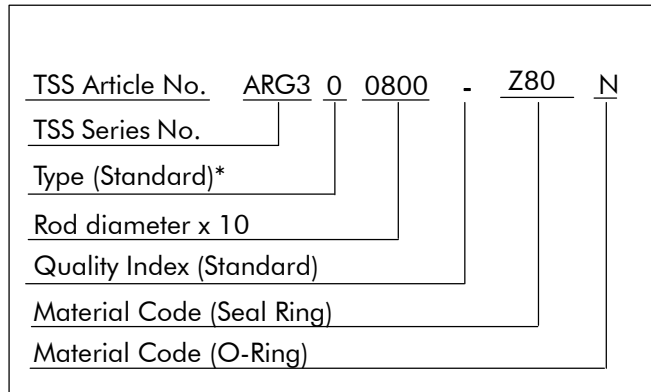

* Ordering Turcon® Glyd Ring® with radial notches please use suffix "N" in the fifth character.



Installation recommendation, type ARG

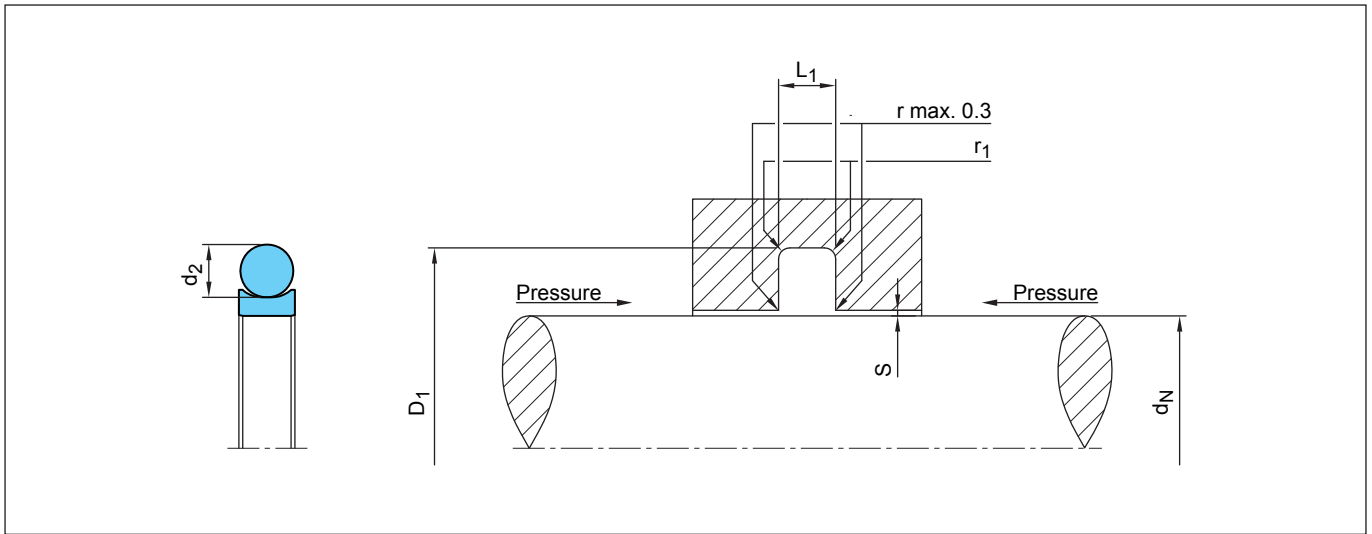

Figure 3 Installation drawing

Table XIV Standard installation dimensions

TSS Series No.	Rod diameter d_N f8/h9		Groove diameter	Groove width	Radius	Radial clearance S_{max}	O-Ring diameter
	Standard range	Available range	D_1 H8	$L_1 + 0.15$	r_1	0 - 5 MPa	d_2
ARG0	3 - 14.9	3 - 49.9	$d_N + 4.0$	2.00	0.5	0.25	1.78
ARG1	15 - 29.9	6 - 119.9	$d_N + 6.0$	2.85	0.5	0.50	2.62
ARG2	30 - 59.9	7 - 399.9	$d_N + 7.5$	3.80	0.8	0.50	3.53
ARG3	60 - 199.9	16 - 799.9	$d_N + 12.5$	5.60	1.3	0.70	5.33
ARG4	200 - 399.9	110 - 799.9	$d_N + 15.0$	7.55	1.5	0.90	7.00
ARG8	400 - 999.9	150 - 999.9	$d_N + 18.0$	7.55	1.5	0.90	7.00

Alternative installation with rod dimensions having tolerance f8/h9 and groove diameter tolerance H9

To obtain consistent compression of the O-Ring the recommended groove diameter tolerance is H8, but for a wide diameter range H9 is also applicable as per Table XV.

Table XV Alternative installation dimensions groove tolerance H9

TSS Series No.	Rod diameter d_N f8/h9	Groove diameter
	Available range	D_1 H9
ARG0	3 - 29.9	$d_N + 4.0$
ARG1	6 - 79.9	$d_N + 6.0$
ARG2	7 - 249.9	$d_N + 7.5$
ARG3	16 - 449.9	$d_N + 12.5$
ARG4	110 - 399.9	$d_N + 15.0$
ARG8	150 - 399.9	$d_N + 18.0$



Rod seal - Type ARG

■ Table XVI Installation dimensions / TSS Part No.

Rod d _N f8/h9	Groove Diameter D ₁ H8	Groove Width L ₁ +0.15	TSS Part No.	O-ring Sizes
3.0*	7.0	2.00	ARG000030	3.68 x 1.78
4.0*	8.0	2.00	ARG000040	4.47 x 1.78
5.0*	9.0	2.00	ARG000050	5.60 x 1.80
5.5*	9.5	2.00	ARG000055	6.07 x 1.78
6.0	10.0	2.00	ARG000060	6.70 x 1.80
7.0*	11.0	2.00	ARG000070	7.65 x 1.78
8.0*	12.0	2.00	ARG000080	8.75 x 1.80
9.0	13.0	2.00	ARG000090	9.50 x 1.80
10.0*	14.0	2.00	ARG000100	10.60 x 1.80
10.0*	16.0	2.85	ARG100100	10.77 x 2.62
11.0	15.0	2.00	ARG000110	11.80 x 1.80
12.0	16.0	2.00	ARG000120	12.42 x 1.78
12.0*	18.0	2.85	ARG100120	12.37 x 2.62
14.0*	20.0	2.85	ARG100140	14.50 x 2.65
15.0*	21.0	2.85	ARG100150	15.54 x 2.62
16.0*	22.0	2.85	ARG100160	17.12 x 2.62
18.0*	24.0	2.85	ARG100180	18.72 x 2.62
18.0*	25.5	3.80	ARG200180	18.66 x 3.53
19.0	25.0	2.85	ARG100190	20.29 x 2.62
20.0	26.0	2.85	ARG100200	20.29 x 2.62
20.0*	27.5	3.80	ARG200200	20.22 x 3.53
22.0	28.0	2.85	ARG100220	23.47 x 2.62
22.0*	29.5	3.80	ARG200220	21.82 x 3.53
23.0*	30.5	3.80	ARG200230	23.40 x 3.53
24.0	30.0	2.85	ARG100240	25.07 x 2.62
25.0	31.0	2.85	ARG100250	25.07 x 2.62
25.0*	32.5	3.80	ARG200250	25.00 x 3.53
25.4	31.4	2.85	ARG100254	26.64 x 2.62
26.0*	33.5	3.80	ARG200260	26.58 x 3.53
28.0	34.0	2.85	ARG100280	28.24 x 2.62
28.0*	35.5	3.80	ARG200280	28.17 x 3.53
30.0*	37.5	3.80	ARG200300	31.35 x 3.53
32.0*	39.5	3.80	ARG200320	32.92 x 3.53
33.0*	40.5	3.80	ARG200330	34.52 x 3.53
35.0*	42.5	3.80	ARG200350	36.09 x 3.53
36.0*	43.5	3.80	ARG200360	37.69 x 3.53
38.0*	45.5	3.80	ARG200380	37.69 x 3.53
38.0*	50.5	5.60	ARG300380	40.64 x 5.33
40.0	47.5	3.80	ARG200400	40.87 x 3.53
40.0*	52.5	5.60	ARG300400	40.64 x 5.33
42.0	49.5	3.80	ARG200420	44.04 x 3.53
44.0*	56.5	5.60	ARG300440	46.99 x 5.33

Rod d _N f8/h9	Groove Diameter D ₁ H8	Groove Width L ₁ +0.15	TSS Part No.	O-ring Sizes
45.0*	52.5	3.80	ARG200450	44.04 x 3.53
45.0*	57.5	5.60	ARG300450	46.99 x 5.33
48.0	55.5	3.80	ARG200480	47.22 x 3.53
50.0	57.5	3.80	ARG200500	50.39 x 3.53
50.0*	62.5	5.60	ARG300500	53.34 x 5.33
50.8	58.3	3.80	ARG200508	51.50 x 3.55
52.0	59.5	3.80	ARG200520	53.57 x 3.53
53.0*	65.5	5.60	ARG200530	56.52 x 5.33
55.0	62.5	3.80	ARG200550	56.74 x 3.53
56.0	63.5	3.80	ARG200560	56.74 x 3.53
56.0*	68.5	5.60	ARG300560	56.52 x 5.33
57.0	64.5	3.80	ARG200570	56.74 x 3.53
58.0	65.5	3.80	ARG200580	59.92 x 3.53
60.0*	72.5	5.60	ARG300600	62.87 x 5.33
63.0*	75.5	5.60	ARG300630	66.04 x 5.33
65.0*	77.5	5.60	ARG300650	66.04 x 5.33
67.0	79.5	5.60	ARG300670	69.22 x 5.33
68.0*	80.5	5.60	ARG300680	69.22 x 5.33
70.0*	82.5	5.60	ARG300700	72.39 x 5.33
73.0	85.5	5.60	ARG300730	75.57 x 5.33
75.0*	87.5	5.60	ARG300750	78.74 x 5.33
76.2	88.7	5.60	ARG300762	78.74 x 5.33
77.0	89.5	5.60	ARG300770	78.74 x 5.33
79.0*	91.5	5.60	ARG300790	81.92 x 5.33
80.0*	92.5	5.60	ARG300800	81.92 x 5.33
82.5	95.0	5.60	ARG300825	85.09 x 5.33
85.0*	97.5	5.60	ARG300850	88.27 x 5.33
88.0*	100.5	5.60	ARG300880	91.44 x 5.33
90.0*	102.5	5.60	ARG300900	91.44 x 5.33
95.0*	107.5	5.60	ARG300950	97.79 x 5.33
98.0*	110.5	5.60	ARG300980	100.97 x 5.33
100.0*	112.5	5.60	ARG301000	104.14 x 5.33
101.6	114.1	5.60	ARG301016	104.14 x 5.33
105.0*	117.5	5.60	ARG301050	107.32 x 5.33
107.0*	119.5	5.60	ARG301070	110.49 x 5.33
108.0	120.5	5.60	ARG301080	110.49 x 5.33
110.0*	122.5	5.60	ARG301100	113.67 x 5.33
115.0	127.5	5.60	ARG301150	116.84 x 5.33
115.0*	130.0	7.55	ARG401150	116.84 x 7.00
117.0*	132.0	7.55	ARG401170	120.02 x 7.00
120.0*	132.5	5.60	ARG301200	123.19 x 5.33
120.0	135.0	7.55	ARG401200	123.19 x 7.00



Rod seal - Type ARG



Rod d _N f8/h9	Groove Diameter D ₁ H8	Groove Width L ₁ +0.15	TSS Part No.	O-ring Sizes
123.00*	138.0	7.55	ARG401230	123.19 x 7.00
125.0	137.5	5.60	ARG301250	126.37 x 5.33
125.0*	140.0	7.55	ARG401250	126.37 x 7.00
127.0	139.5	5.60	ARG301270	129.54 x 5.33
130.0	142.5	5.60	ARG301300	132.72 x 5.33
130.0*	145.0	7.55	ARG401300	132.72 x 7.00
132.0	144.5	5.60	ARG301320	135.89 x 5.33
133.0*	148.0	7.55	ARG401330	135.89 x 7.00
135.0	147.5	5.60	ARG301350	135.89 x 5.33
135.0*	150.0	7.55	ARG401350	135.89 x 7.00
140.0	152.5	5.60	ARG301400	142.24 x 5.33
140.0*	155.0	7.55	ARG401400	142.24 x 7.00
142.0*	157.0	7.55	ARG401420	142.24 x 7.00
145.0	157.5	5.60	ARG301450	148.49 x 5.33
145.0*	160.0	7.55	ARG401450	145.42 x 7.00
150.0	162.5	5.60	ARG301500	151.77 x 5.33
150.0*	165.0	7.55	ARG401500	151.77 x 7.00
152.4	164.9	5.60	ARG301524	151.77 x 5.33
155.0	167.5	5.60	ARG301550	158.12 x 5.33
155.0*	173.0	7.55	ARG801550	158.12 x 7.00
160.0	172.5	5.60	ARG301600	164.47 x 5.33
160.0*	178.0	7.55	ARG801600	164.47 x 7.00
165.0	177.5	5.60	ARG301650	170.82 x 5.33
165.0*	183.0	7.55	ARG801650	170.82 x 7.00
170.0	182.5	5.60	ARG301700	170.82 x 5.33
170.0*	188.0	7.55	ARG801700	177.17 x 7.00
175.0	187.5	5.60	ARG301750	177.17 x 5.33
175.0*	193.0	7.55	ARG801750	177.17 x 7.00
180.0	192.5	5.60	ARG301800	183.52 x 5.33
180.0*	198.0	7.55	ARG801800	183.52 x 7.00
190.0	202.5	5.60	ARG301900	196.22 x 5.33
190.0*	208.0	7.55	ARG801900	196.22 x 7.00
194.0	206.5	5.60	ARG301940	202.57 x 5.33
195.0*	213.0	7.55	ARG801950	202.57 x 7.00
200.0*	215.0	7.55	ARG402000	202.57 x 7.00
203.2	218.2	7.55	ARG402032	202.57 x 7.00
205.0	220.0	7.55	ARG402050	208.90 x 7.00
210.0	225.0	7.55	ARG402100	215.27 x 7.00
215.0	230.0	7.55	ARG402150	215.27 x 7.00
220.0*	235.0	7.55	ARG402200	215.27 x 7.00
230.0*	245.0	7.55	ARG402300	227.97 x 7.00
240.0	255.0	7.55	ARG402400	240.67 x 7.00

Rod d _N f8/h9	Groove Diameter D ₁ H8	Groove Width L ₁ +0.15	TSS Part No.	O-ring Sizes
250.0	265.0	7.55	ARG402500	253.37 x 7.00
254.0	269.0	7.55	ARG402540	253.37 x 7.00
260.0	275.0	7.55	ARG402600	266.07 x 7.00
265.0	280.0	7.55	ARG402650	266.07 x 7.00
268.0	283.0	7.55	ARG402680	266.07 x 7.00
270.0	285.0	7.55	ARG402700	266.07 x 7.00
280.0	295.0	7.55	ARG402800	278.77 x 7.00
290.0	305.0	7.55	ARG402900	291.47 x 7.00
300.0	315.0	7.55	ARG403000	304.17 x 7.00
304.8	319.8	7.55	ARG403048	304.17 x 7.00
310.0	325.0	7.55	ARG403100	316.87 x 7.00
320.0	335.0	7.55	ARG403200	316.87 x 7.00
330.0	345.0	7.55	ARG403300	329.57 x 7.00
340.0	355.0	7.55	ARG403400	342.27 x 7.00
350.0	365.0	7.55	ARG403500	354.97 x 7.00
360.0	375.0	7.55	ARG403600	367.67 x 7.00
370.0	385.0	7.55	ARG403700	367.67 x 7.00
380.0	395.0	7.55	ARG403800	380.37 x 7.00
400.0	418.0	7.55	ARG804000	405.26 x 7.00
425.0	443.0	7.55	ARG804250	430.66 x 7.00
450.0	468.0	7.55	ARG804500	456.06 x 7.00
475.0	493.0	7.55	ARG804750	481.38 x 7.00
500.0	518.0	7.55	ARG805000	506.86 x 7.00
525.0	543.0	7.55	ARG805250	532.26 x 7.00
550.0	568.0	7.55	ARG805500	557.66 x 7.00
575.0	593.0	7.55	ARG805750	582.68 x 7.00
600.0	618.0	7.55	ARG806000	608.08 x 7.00
650.0	688.0	7.55	ARG806500	658.88 x 7.00
700.0	718.0	7.55	ARG807000	704.49 x 7.00
750.0	768.0	7.55	ARG807500	754.49 x 7.00
800.0	818.0	7.55	ARG808000	804.49 x 7.00
850.0	868.0	7.55	ARG808500	854.49 x 7.00
900.0	918.0	7.55	ARG809000	904.49 x 7.00
950.0	968.0	7.55	ARG809500	954.49 x 7.00
999.9	1017.9	7.55	ARG809999	1004.39 x 7.00

* Standard diameter for Turcon® Glyd Ring® RG58

Other dimensions and all intermediate sizes up to 999.9 mm diameter can be supplied.

For rod diameters >999.9 mm and up to 2.600 mm use the RG45 series Turcon® Glyd Ring®.



Piston Seal - Type APDE

■ Piston seal type APDE

Description

Single acting piston seal with U-shaped cross-section. For double acting pistons, two seals are used "back to back".

Special lip design for pneumatic application to maintain lubricating film and minimize friction.

Suitable for cylinders with pneumatic cushioning.

Technical data

Operating pressure: 1.6 MPa

Speed: ≤ 1 m/s

Temperature: from -40 °C to +80 °C

Media: oil free air (initial grease lubrication required), lubricated air, nonaggressive gases

Material

Standard polyurethane with fair performance level.

Standard Material: Polyurethane, 90 Shore A, Material No.: WU9E1

Installation

Snap-in installation into closed grooves. It is important to remove all sharp edges and burrs from the groove and tube before installation.

Ordering example

Piston Seal,
type APDE
Piston diameter: D = 50 mm
Groove width: L = 7.5 mm
TSS Part No.: APDE00500 (Table XVII)
Material No.: WU9E1

TSS Article No.	APDE0	0500	-	WU9E1
TSS Series No.				
Piston diameter x 10				
Material Code				



Installation recommendation, type APDE

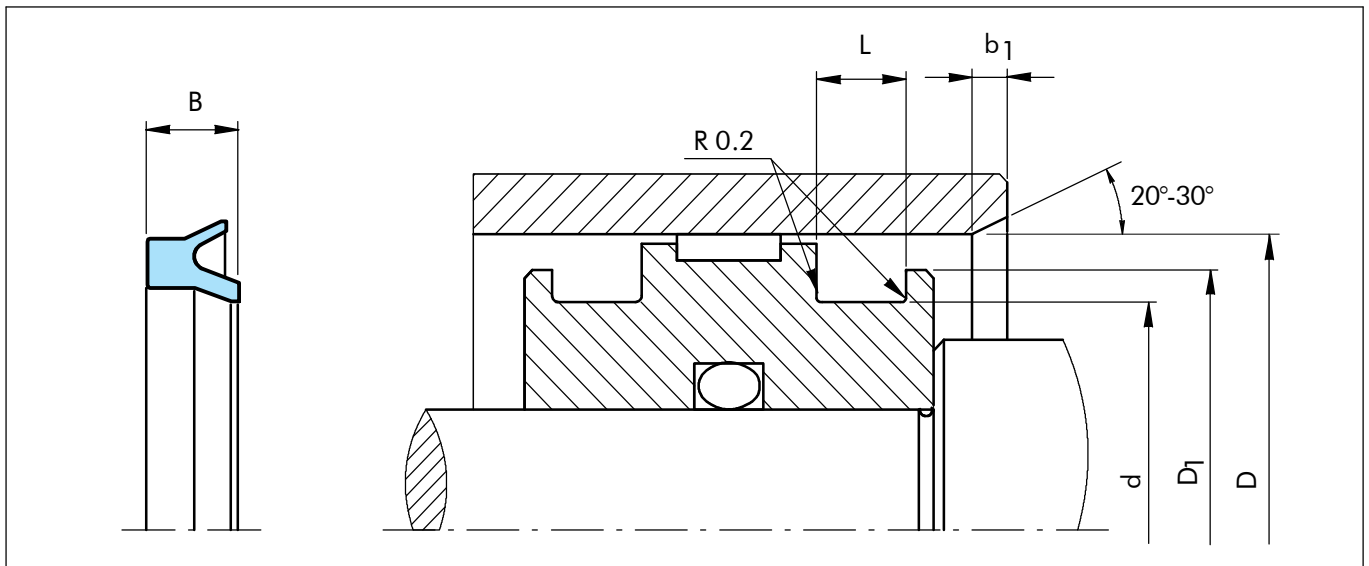

Figure 4 Installation drawing

Table XVII Installation dimensions / TSS Part No.

Bore diameter	Flange diameter	Groove diameter	Groove width	Ring width	Inlet chamfer	TSS Part No.
D H10	D ₁ h10	d h10	L +0.2	B	b ₁	
4.0	3.0	1.5	2.0	1.5	1.0	APDE00040
5.0	4.0	2.5	2.0	1.5	1.0	APDE00050
6.0	5.0	3.0	2.5	2.0	1.0	APDE00060
8.0	7.0	4.0	3.0	2.55	1.5	APDE00080
8.0	7.0	4.8	2.7	2.3	1.5	APDE10080
8.0	7.0	4.8	3.0	2.55	1.5	APDE20080
10.0	9.0	6.0	3.0	2.55	1.5	APDE00100
12.0	11.0	7.0	3.0	2.55	1.5	APDE00120
13.0	12.0	8.0	3.0	2.55	1.5	APDE00130
14.0	13.0	8.0	3.0	2.55	1.5	APDE00140
15.0	14.0	9.0	3.0	2.55	1.5	APDE00150
16.0	15.0	10.0	3.0	2.55	2.0	APDE00160
17.0	16.0	11.0	3.0	2.55	2.0	APDE00170
18.0	17.0	12.0	3.0	2.55	2.0	APDE00180
20.0	19.0	12.0	6.0	5.5	2.0	APDE20200
20.0	19.0	14.0	3.0	2.55	2.0	APDE00200
20.0	19.0	14.0	4.5	4.0	2.0	APDE10200
22.0	21.0	16.0	3.0	2.55	2.0	APDE00220
24.0	23.0	18.0	3.0	2.55	2.0	APDE00240
25.0	24.0	17.0	6.0	5.5	2.0	APDE10250
25.0	24.0	19.0	3.5	3.25	2.0	APDE00250
25.0	24.0	19.0	4.5	4.0	2.0	APDE20250
28.0	27.0	18.0	7.5	7.0	2.0	APDE10280
28.0	27.0	22.0	3.5	3.25	2.0	APDE00280



Piston Seal - Type APDE

Bore diameter	Flange diameter	Groove diameter	Groove width	Ring width	Inlet chamfer	TSS Part No.
D H10	D ₁ h10	d h10	L +0.2	B	b ₁	
30.0	29.0	22.0	3.5	3.25	2.0	APDE00300
32.0	31.0	24.0	3.5	3.25	2.0	APDE00320
32.0	31.0	24.0	6.0	5.5	2.0	APDE10320
35.0	34.0	27.0	3.5	3.25	2.0	APDE00350
36.0	35.0	28.0	3.5	3.25	2.0	APDE00360
38.0	37.0	30.0	3.5	3.25	2.0	APDE00380
38.0	37.0	30.0	6.0	5.5	2.0	APDE10380
40.0	39.0	30.0	7.5	7.0	2.5	APDE00400
40.0	39.0	32.0	3.5	3.25	2.5	APDE10400
42.0	41.0	30.0	6.5	6.0	2.5	APDE10420
42.0	41.0	34.0	3.5	3.25	2.5	APDE00420
45.0	44.0	37.0	3.5	3.25	2.5	APDE00450
50.0	49.0	40.0	5.5	5.0	2.5	APDE20500
50.0	49.0	40.0	7.5	7.0	2.5	APDE00500
50.0	49.0	42.0	3.5	3.25	2.5	APDE10500
52.0	51.0	42.0	4.5	4.25	2.5	APDE00520
55.0	54.0	45.0	7.5	7.0	2.5	APDE00550
58.0	57.0	48.0	4.5	4.25	2.5	APDE00580
60.0	59.0	50.0	5.7	5.0	2.5	APDE00600
60.0	59.0	50.0	7.5	7.0	2.5	APDE10600
63.0	62.0	53.0	4.5	4.25	2.5	APDE10630
63.0	62.0	53.0	7.5	7.0	2.5	APDE00630
65.0	64.0	55.0	7.5	7.0	2.5	APDE00650
68.0	67.0	58.0	5.5	4.7	2.5	APDE00680
70.0	69.0	58.0	9.5	8.5	2.5	APDE00700
75.0	74.0	63.0	9.5	8.5	2.5	APDE00750
80.0	79.0	67.3	7.0	6.35	2.5	ADPE20800
80.0	79.0	68.0	9.5	8.5	2.5	APDE00800
80.0	79.0	70.0	4.5	4.25	2.5	APDE10800
85.0	84.0	73.0	9.5	8.5	2.5	APDE00850
90.0	89.0	78.0	9.5	8.5	2.5	APDE00900
90.0	89.0	80.0	4.5	4.25	2.5	APDE10900
100.0	99.0	88.0	9.5	8.5	2.5	APDE01000
100.0	99.0	90.0	4.5	4.25	2.5	APDE21000
110.0	109.0	95.0	11.0	10.0	3.0	APDE01100
120.0	119.0	105.0	11.0	10.0	3.0	APDE01200
125.0	124.0	105.0	8.5	8.25	3.0	APDE01250
125.0	124.0	110.0	11.0	10.0	3.0	APDE11250
140.0	139.0	120.0	8.5	8.25	3.0	APDE01400
152.0	151.0	145.0	4.0	3.75	2.5	APDE01520
160.0	159.0	140.0	8.5	8.25	3.0	APDE01600
160.0	159.0	145.0	11.0	10.0	3.0	APDE11600
180.0	179.0	160.0	15.0	14.0	3.0	APDE01800
200.0	199.0	180.0	8.5	8.25	3.0	APDE02000
200.0	199.0	180.0	15.0	14.0	3.0	APDE12000
250.0	249.0	230.0	15.0	14.0	3.0	APDE02500



■ Piston seal type APDF

Description

A seal perfectly suited for standard pneumatic applications and made from a special polyurethane type developed for piston seals.

Seal dimensions are in line with cylinder diameters according to ISO 3320.

Seal design guarantees high reliability and simple snap assembly.

The seal has an optimized, stick-slip reducing design for use in endpositioned damped cylinders with exhaust throttles.

The particular polyurethane offers exceptional wear resistance and extremely high operating performance. Special lip design for pneumatic application to maintain lubrication and minimize friction.

Technical data

Operating pressure:	1.6 MPa
Speed:	<= 1 m/s
Temperature:	-35 °C to +85 °C
Media:	oil free air (initial grease lubrication required), lubricated air, nonaggressive gases

Material

Standard Material: Zurcon® PU, 83 Shore A, colour grey-blue
Material No.: Z30

Installation

Snap-in installation into closed grooves. It is important to remove all sharp edges and burrs from the groove and tube before installation.

Ordering example

Piston Seal,
type APDF
Piston diameter: D = 50 mm
Groove width: L = 7.5 mm
TSS Part No.: APDF00500 (Table XVIII)
Material No.: Z30

TSS Article No.	APDF	0500	-	Z30
TSS Series No.				
Piston diameter x 10				
Material Code				



Piston Seal - Type APDF

Installation recommendation, type APDF

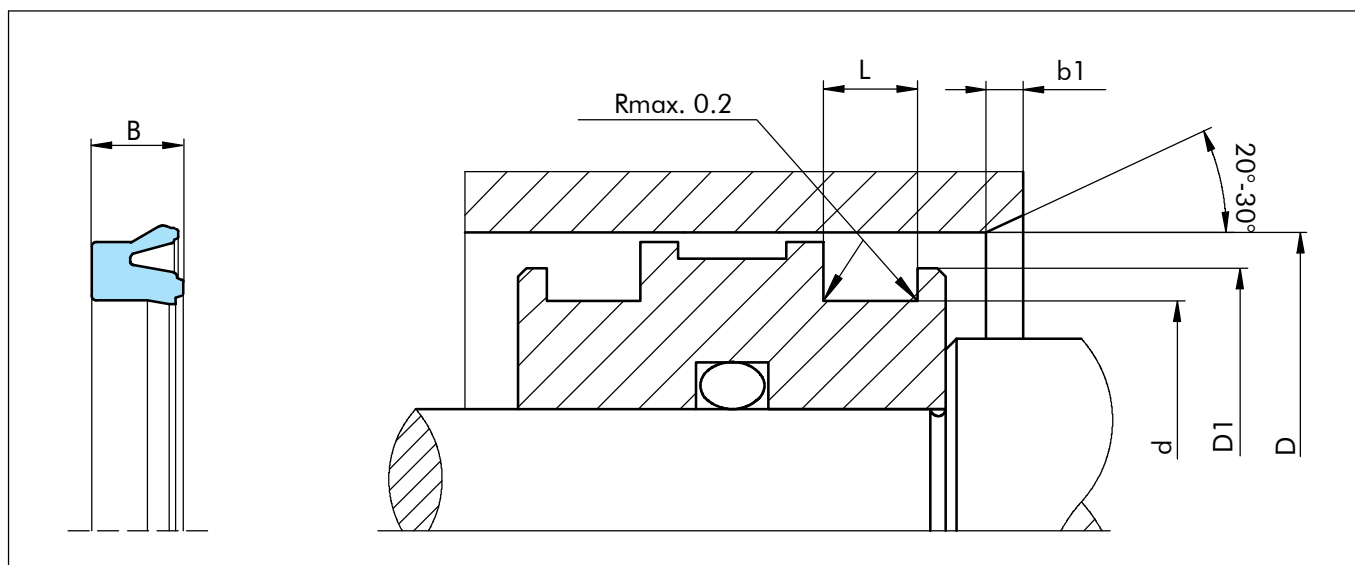

Figure 5 Installation drawing

Table XVIII Installation dimensions / TSS Part No.

Bore diameter	Flange diameter	Groove diameter	Groove width	Ring width	Inlet chamfer	TSS Part No.
D H10	D ₁ h10	d h10	L +0.2	B	b ₁	
25.0	24.0	17.0	6.0	5.5	2.0	APDF00250
32.0	31.0	24.0	6.0	5.5	2.0	APDF00320
40.0	39.0	30.0	7.5	7.0	2.5	APDF00400
50.0	49.0	40.0	7.5	7.0	2.5	APDF00500
63.0	62.0	53.0	7.5	7.0	2.5	APDF00630
80.0	79.0	68.0	9.5	8.5	2.5	APDF00800
100.0	99.0	88.0	9.5	8.5	2.5	APDF01000
125.0	124.0	110.0	11.0	10.0	3.0	APDF01250



■ Piston seal type APDG

Description

A seal perfectly suited for standard pneumatic applications and small installation space made from a special polyurethane type developed for piston seals.

Seal dimensions are in line with cylinder diameters according to ISO 3320.

Seal design guarantees high reliability and simple snap assembly.

This particular polyurethane offers exceptional wear resistance and extremely high operating performance. Special lip design for pneumatic application to maintain lubrication film and minimize friction.

The seal has an optimized, stick-slip reducing design for use in endpositioned damped cylinders with exhaust throttles.

Technical data

Operating pressure:	1.6 MPa
Speed:	<= 1 m/s
Temperature:	-35 °C to +85 °C
Media:	oil free air (initial grease lubrication required), lubricated air, nonaggressive gases

Material

Standard Material: Zurcon® PU, 83 Shore A, colour grey-blue
Material No.: Z30

Installation

Snap-in installation into closed grooves. It is important to remove all sharp edges and burrs from the groove and tube before installation.

Ordering example

Piston Seal,
type APDG
Piston diameter: D = 50 mm
Groove width: L = 3.5 mm
TSS Part No.: APDG00500 (Table XIX)
Material No.: Z30

TSS Article No.	APDG0	0500	-	Z30
TSS Series No.				
Piston diameter x 10				
Material Code				



Piston Seal - Type APDG

Installation recommendation, type APDG

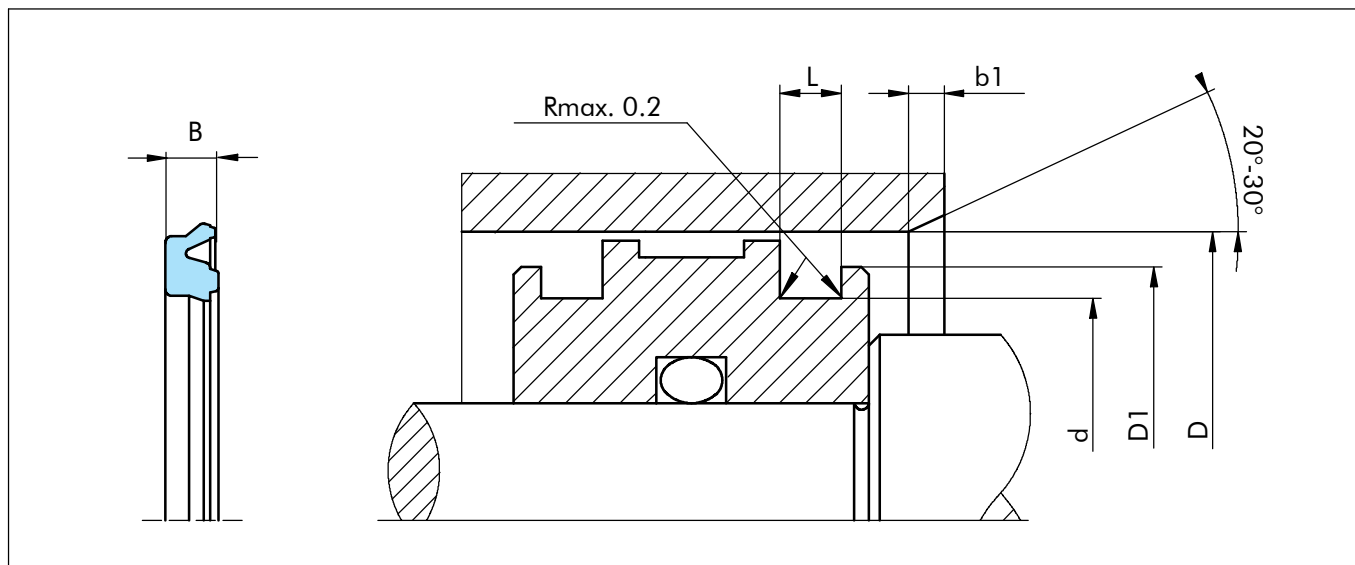

Figure 6 Installation drawing

Table XIX Installation dimensions / TSS Part No.

Bore diameter	Flange diameter	Groove diameter	Groove width	Ring width	Inlet chamfer	TSS Part No.
D H10	D ₁ h10	d h10	L +0.2	B	b ₁	
32.0	31.0	24.0	3.5	3.3	2.0	APDG00320
40.0	39.0	32.0	3.5	3.3	2.5	APDG00400
42.0	41.0	34.0	3.5	3.3	2.5	APDG00420
50.0	49.0	42.0	3.5	3.3	2.5	APDG00500
63.0	62.0	53.0	4.5	4.3	2.5	APDG00630
80.0	79.0	70.0	4.5	4.3	2.5	APDG00800
100.0	99.0	90.0	4.5	4.3	2.5	APDG01000



■ Piston seal type APDS

Description

Single acting piston seal with U-shaped cross-section. For double acting pistons, two seals are used "back to back". Same design as APDE-type, but lower interference of the dynamic lip for reduced friction and break-off pressure. Recommended for return spring cylinders. Note: good guiding system required. Suitable for cylinders with pneumatic cushioning.

Technical data

Operating pressure: 1.6 MPa
 Speed: ≤ 1 m/s
 Temperature: from -40 °C to +80 °C
 Media: oil free air (initial grease lubrication required), lubricated air, nonaggressive gases

Material

Standard polyurethane with fair performance level.

Standard Material: Polyurethane, 90 Shore A,
 Material No.: WU9E1

Installation

Snap-in installation into closed grooves. It is important to remove all sharp edges and burrs from the groove and tube before installation.

Ordering example

Piston Seal,
 type APDS
 Piston diameter: D = 20 mm
 Groove width: L = 3 mm
 TSS Part No.: APDS00200 (Table XX)
 Material No.: WU9E1

TSS Article No.	APDS0	0200	-	WU9E1
TSS Series No.				
Piston diameter x 10				
Material Code				



Piston Seal - Type APDS

Installation recommendation, type APDS

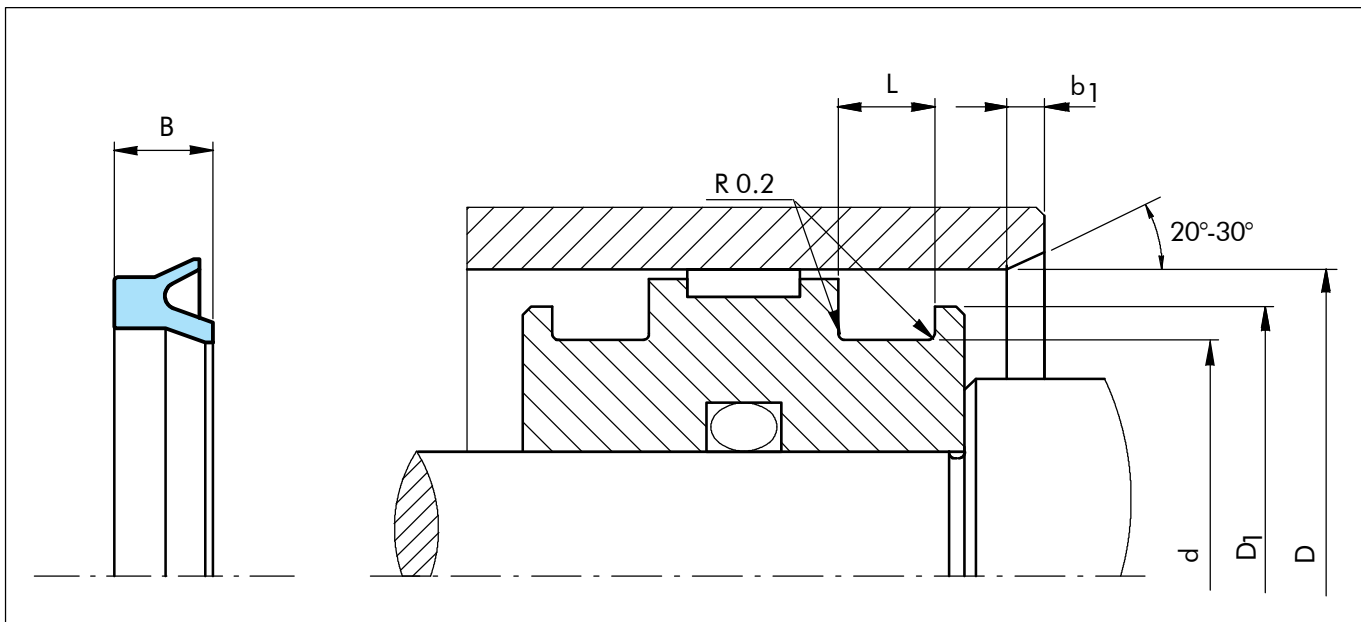

Figure 7 Installation drawing

Table XX Installation dimensions / TSS Part No.

Bore diameter	Flange diameter	Groove diameter	Groove width	Ring width	Inlet chamfer	TSS Part No.
D H10	D ₁ h10	d h10	L +0.2	B	b ₁	
6.0	5.0	3.0	2.5	2.0	1.0	APDS00060
8.0	7.0	4.0	3.0	2.55	1.5	APDS00080
8.0	7.0	4.0	3.0	2.55	1.5	APDS20080
10.0	9.0	6.0	3.0	2.55	1.5	APDS00100
12.0	11.0	7.0	3.0	2.55	1.5	APDS00120
14.0	13.0	8.0	3.0	2.55	1.5	APDS00140
16.0	15.0	10.0	3.0	2.55	2.0	APDS00160
17.0	16.0	11.0	3.0	2.55	2.0	APDS00170
18.0	17.0	12.0	3.0	2.55	2.0	APDS00180
20.0	19.0	14.0	3.0	2.55	2.0	APDS00200
25.0	24.0	19.0	3.5	3.25	2.0	APDS00250
27.0	26.0	21.0	3.5	3.25	2.0	APDS00270
30.0	29.0	22.0	3.5	3.25	2.0	APDS00300
32.0	31.0	24.0	3.5	3.25	2.0	APDS00320
35.0	34.0	27.0	3.5	3.25	2.0	APDS00350
40.0	39.0	32.0	3.5	3.25	2.5	APDS10400
50.0	49.0	42.0	3.5	3.25	2.5	APDS00500
63.0	62.0	53.0	4.5	4.25	2.5	APDS00630
80.0	79.0	70.0	4.5	4.25	2.5	APDS00800
100.0	99.0	90.0	4.5	4.25	2.5	APDS01000



■ Piston seal type APMP

Description

Single acting piston seal with integrated guiding element and buffer for mechanical cushioning. For double acting pistons, two seals are used "back to back". Suitable for short stroke cylinders and/or magnetic pistons. The magnet is protected between the piston seals.

Technical data

Operating pressure: 1.6 MPa
 Speed: ≤ 1 m/s
 Temperature: from -40 °C to +80 °C
 Media: oil free air (initial grease lubrication required), lubricated air, nonaggressive gases

Material

Standard polyurethane with fair performance level.

Standard Material: Polyurethane, 90 Shore A,
 Material No.: WU9E1

Installation

The installation is done by forced overlapping on the piston diameter, shaped in a proper way to fit the retainer tooth of the seal.

Ordering example

Piston Seal
 type APMP
 Piston diameter: D = 32 mm
 Magnet groove width: t = 3 mm
 TSS Part No.: APMP00320 (Table XXII)
 Material No.: WU9E1

TSS Article No.	APMP0	0320	-	WU9E1
TSS Series No.				
Piston diameter x 10				
Material Code				



Piston Seal - Type APMP

Installation recommendation, type APMP

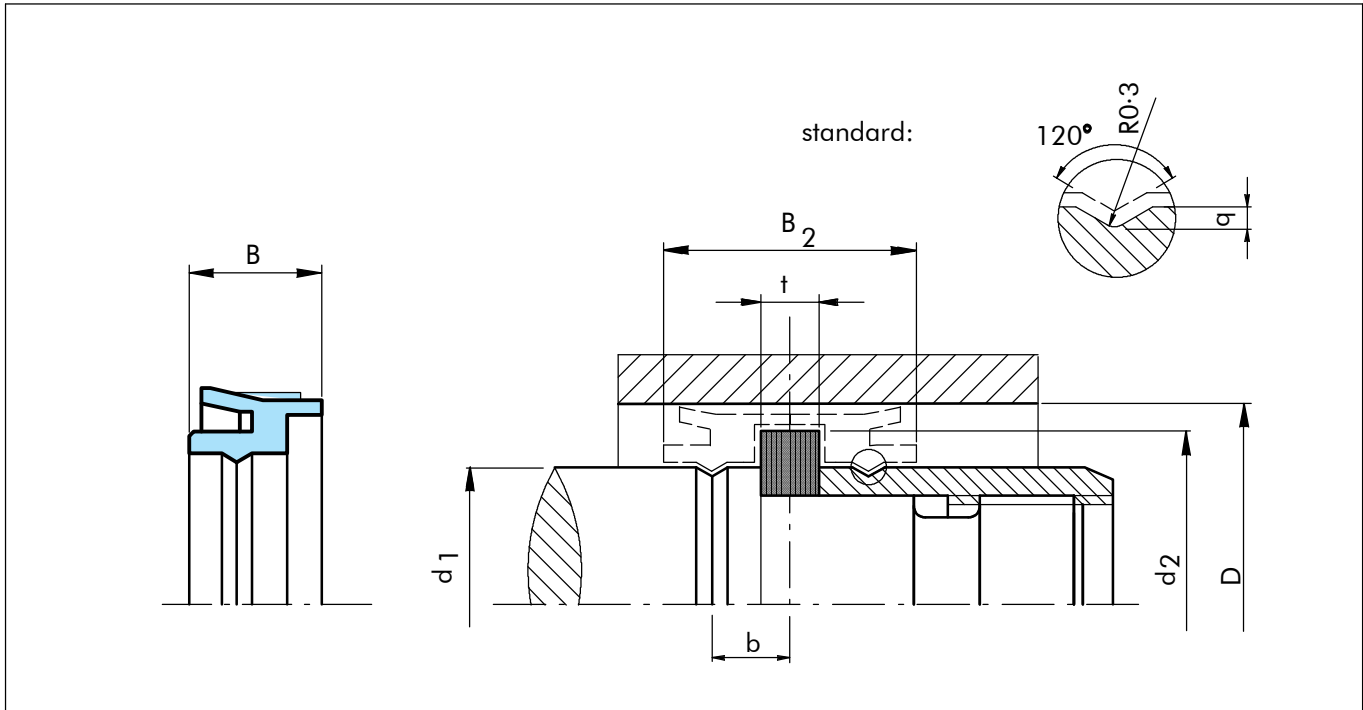

Figure 8 Installation drawing

Table XXI Installation dimensions / TSS Part No.

Bore diameter	Piston axial width	Ring width	Magnet groove width	Retainer deviation	Coupling diameter	Retainer depth	Magnet diameter	TSS Part No.
D	B ₂	B	t	b	d ₁ h7	q	d ₂	
8.0	12.0	6.0	4.0	4.0	4.0	0.35	6.5	APMP00080
10.0	12.0	6.0	3.0	3.5	4.0	0.35	8.5	APMP00100
12.0	12.0	6.0	3.0	3.5	6.0	0.40	10.5	APMP00120
16.0	12.0	6.0	3.0	3.5	8.0	0.40	14.5	APMP00160
20.0	12.0	6.0	3.0	3.5	10.0	0.50	18.0	APMP00200
25.0	12.0	6.0	3.0	3.5	10.0	0.50	23.0	APMP00250



Installation recommendation, type APMP

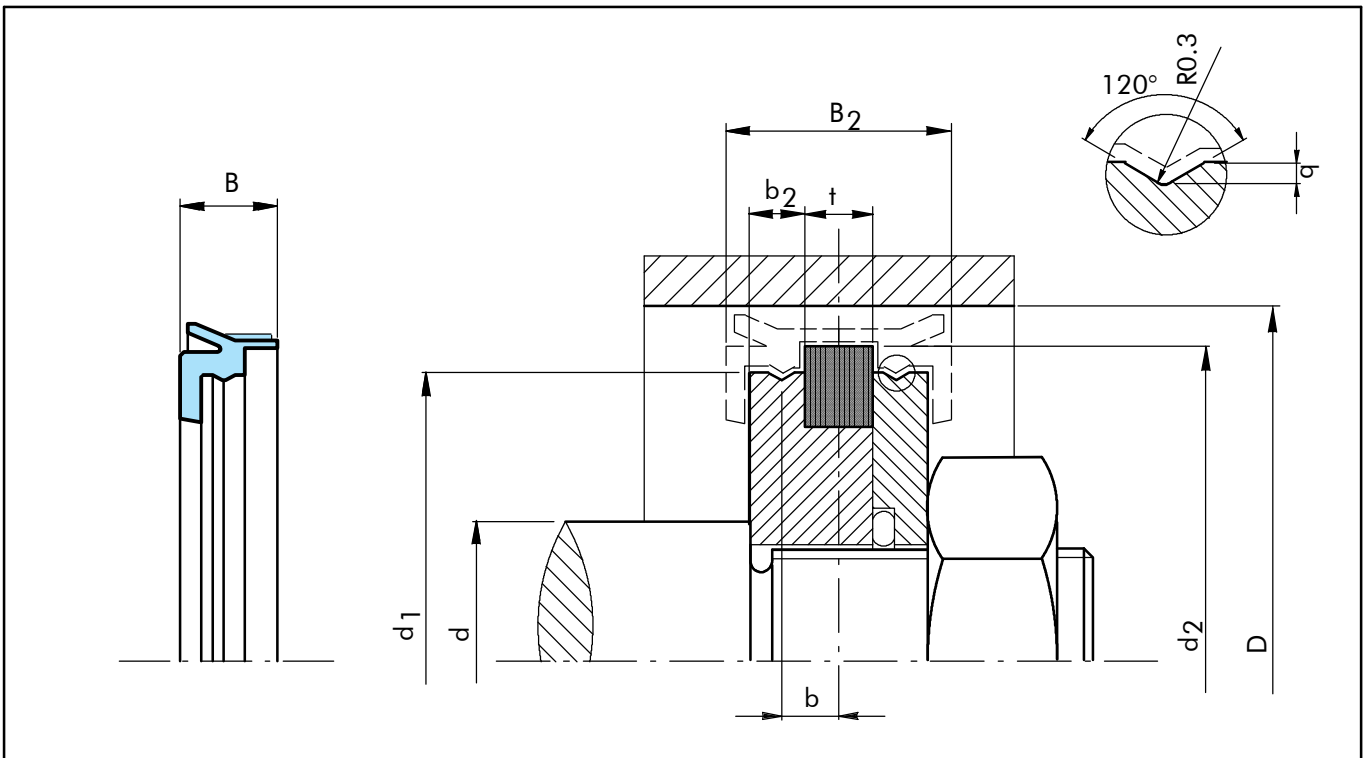

Figure 9 Installation drawing

Table XXII Installation dimensions / TSS Part No.

Bore diameter	Seal axial width	Ring width	Magnet groove width	Retainer deviation	Profile width	Piston diameter	Retainer depth	Rod diameter	Magnet diameter	TSS Part No.
D	B ₂	B	t	b	b ₂ +0.1	d ₁ h7	q	d _h 7	d ₂	
32.0	14.0	7.0	3.0	4.0	2.9	26.0	0.5	12.0	29.5	APMP00320
32.0	14.0	7.0	5.0	4.0	2.9	26.0	0.5	12.0	29.5	APMP10320
40.0	14.5	7.25	5.0	4.25	3.5	34.0	0.5	12.0	37.5	APMP00400
50.0	14.5	7.25	5.0	4.25	3.4	43.0	0.6	16.0	46.5	APMP00500
63.0	20.0	10.0	5.0	6.0	5.9	55.0	0.8	16.0	59.5	APMP00630
80.0	22.0	11.0	5.0	6.5	6.9	72.0	0.8	20.0	76.5	APMP00800
100.0	26.0	13.0	5.0	7.5	8.4	90.0	0.8	25.0	96.5	APMP01000



Piston Seal - Type APG

■ Piston seal type APG

Description

Double acting Glyd Ring® piston seal comprising a slipper seal and an energising O-Ring. Specially designed for low friction pneumatic applications with small installation space. Suitable for cylinders with pneumatic cushioning. Available for all diameters from 6 to 2700 mm.

Technical data

- Operating pressure: 1.6 MPa (max. 5 MPa)
- Speed: <=5 m/s
- Temperature*: -30 °C ... +200 °C (other temperature ranges on request)
- Media: oil free air (initial grease lubrication recommended), lubricated air, nonaggressive gases - depending on the O-Ring material compatibility.

Material

- Standard Material: Zurcon® Z80, ultra-high-molecular weight-polyethylen, 61 Shore D, colour white to off-white. Maximum temperature: 80 °C Material No.: Z80N or Z80V *
- Alternative: Turcon® T19, high grade composition of PTFE resin with mineral fibre intensifier, 62 Shore D, colour dark green-grey. Maximum temperature: 200 °C Material No.: T19N or T19V *

* depends on O-Ring material (N=NBR / V=FKM)

- O-Ring material: N7083 NBR 70 Shore A (-30 °C ... +100 °C)
V70GA FKM 70 Shore A (-10 °C ... +200 °C)

Installation

Installation into colsed grooves above piston diameter 15 mm (above 10 mm for T19). Direct O-Ring installation followed by snap in Glyd Ring®. When Glyd Ring® is mounted over a wear ring groove an installation sleeve must be used (specimen drawing upon request). It is important to remove all sharp edges and burrs from the groove and tube before installation.

Ordering example

Turcon Glyd Ring APG complete with O-Ring. Standard application. Series APG from Table XXIII
Piston diameter: $D_N = 270$ mm
TSS Part No.: APG802700 from Table XXV

Select the material from Table I. The corresponding code numbers are appended to the TSS Part No. from Table XXV. Together they form the TSS Article number.

Other dimensions and all intermediate sizes up to <999.9 mm diameter can be supplied. Fore bore diameters >999.9 mm and up to 2.700 mm use the PG46 series Turcon® Glyd Ring®.

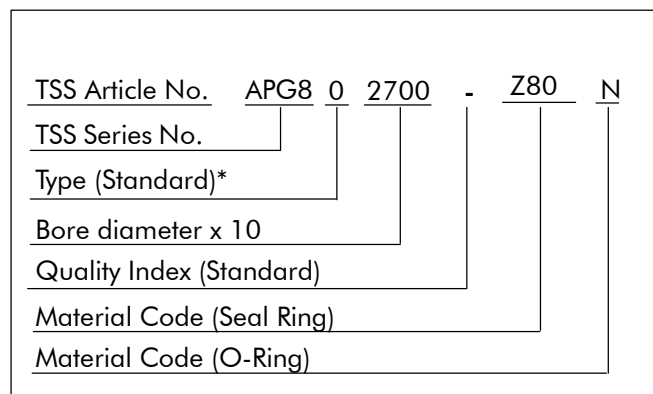

* Ordering Turcon® Glyd Ring® with radial notches please use suffix "N" in the fifth character.



Installation recommendation, type APG

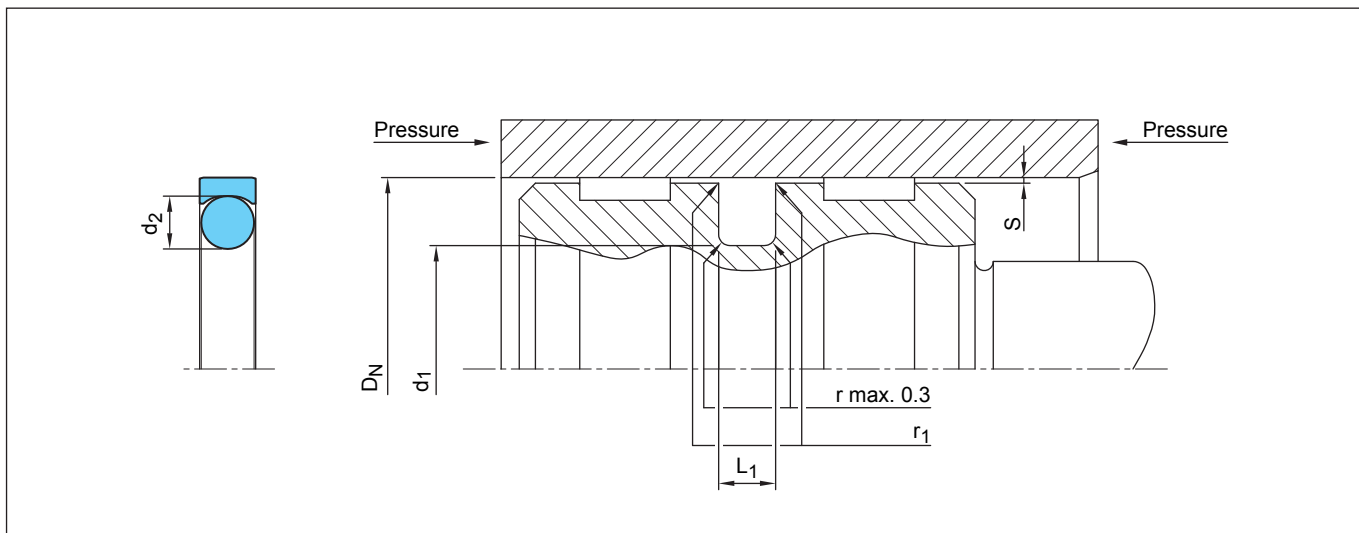

Figure 10 Installation drawing

Table XXIII Standard installations dimensions

TSS Series No	Bore diameter D_N H9		Groove diameter	Groove width	Radius	Radial clearance S_{max}	O-Ring diameter
	Standard range	Available range	d_1 h8	$L_1 + 0.15$	r_1	0 - 5 MPa	d_2
APG0	8 - 13.9	6 - 49.9	$D_N - 4.0$	2.00	0.5	0.25	1.78
APG1	14 - 29.9	10 - 119.9	$D_N - 6.0$	2.85	0.5	0.50	2.62
APG2	30 - 79.9	15 - 399.9	$D_N - 7.5$	3.80	0.8	0.50	3.53
APG3	80 - 132.9	40 - 799.9	$D_N - 12.5$	5.60	1.3	0.70	5.33
APG4	133 - 249.9	110 - 799.9	$D_N - 15.0$	7.55	1.5	0.90	7.00
APG8	250 - 999.9	150 - 999.9	$D_N - 18.0$	7.55	1.5	0.90	7.00

For Standard Tube Tolerances H11

To extend the availability of cylinder tubes up to a bore tolerance of H11 a limited range of diameter are applicable as per Table XXIV.

Table XXIV Alternative installation with bore dimensions having tolerance H11 and d_1 h8

TSS Series No.	Bore diameter D_N H11	Groove diameter
	Available range	d_1 h8
APG0	Not recommended	$D_N - 4.0$
APG1	Not recommended	$D_N - 6.0$
APG2	15 - 29.9	$D_N - 7.5$
APG3	40 - 179.9	$D_N - 12.5$
APG4	110 - 179.9	$D_N - 15.0$
APG8	150 - 179.9	$D_N - 18.0$



Piston Seal - Type APG

Table XXV Installation dimensions / TSS Part No.

Rod D _N H9	Groove Diameter D ₁ h8	Groove Width L ₁ +0.15	TSS Part No.	O-ring Sizes
8.0*	4.0	2.00	APG000080	3.68 x 1.78
9.0*	5.0	2.00	APG000090	4.80 x 18.0
10.0*	6.0	2.00	APG000100	5.60 x 1.80
11.0*	7.0	2.00	APG000110	6.70 x 1.80
12.0*	8.0	2.00	APG000120	7.65 x 1.78
14.0	8.0	2.85	APG100140	7.59 x 2.62
15.0	9.0	2.85	APG100150	9.19 x 2.62
16.0*	10.0	2.85	APG100160	9.19 x 2.62
18.0*	12.0	2.85	APG100180	10.77 x 2.62
19.0*	13.0	2.85	APG100190	12.37 x 2.62
20.0*	14.0	2.85	APG100200	13.94 x 2.62
22.0*	16.0	2.85	APG100220	15.54 x 2.62
24.0	18.0	2.85	APG100240	17.12 x 2.62
25.0*	19.0	2.85	APG100250	18.72 x 2.62
25.4	19.4	2.85	APG100254	18.72 x 2.62
27.0*	21.0	2.85	APG100270	20.29 x 2.62
28.0	22.0	2.85	APG100280	21.89 x 2.62
28.0*	20.5	3.80	APG200280	20.22 x 3.53
30.0*	22.5	3.80	APG200300	21.82 x 3.53
32.0*	24.5	3.80	APG200320	23.40 x 3.53
34.0*	26.5	3.80	APG200340	26.58 x 3.53
35.0*	27.5	3.80	APG200350	26.58 x 3.53
36.0	28.5	3.80	APG200360	28.17 x 3.53
37.0*	29.5	3.80	APG200370	28.17 x 3.53
38.0*	30.5	3.80	APG200380	29.75 x 3.53
40.0*	32.5	3.80	APG200400	31.35 x 3.53
42.0*	34.5	3.80	APG200420	34.52 x 3.53
43.0*	35.5	3.80	APG200430	34.52 x 3.53
44.0*	36.5	3.80	APG200440	36.09 x 3.53
45.0	37.5	3.80	APG200450	36.09 x 3.53
48.0	40.5	3.80	APG200480	40.87 x 3.53
50.0	42.5	3.80	APG200500	40.87 x 3.53
50.0*	37.5	5.60	APG300500	37.47 x 5.33
50.8	43.3	3.80	APG200508	40.87 x 3.53
52.0	44.5	3.80	APG200520	44.04 x 3.53
55.0	47.5	3.80	APG200550	47.22 x 3.53
55.0*	42.5	5.60	APG300550	40.64 x 5.33
57.0	49.5	3.80	APG200570	47.22 x 3.53
58.0	50.5	3.80	APG200580	50.39 x 3.53
58.0*	45.5	5.60	APG300580	43.82 x 5.33
60.0	52.5	3.80	APG200600	51.50 x 3.55
60.0*	47.5	5.60	APG300600	46.99 x 5.33
62.0	54.5	3.80	APG200620	53.57 x 3.53
63.0	55.5	3.80	APG200630	53.57 x 3.53
63.0*	50.5	5.60	APG300630	50.17 x 5.33

Rod D _N H9	Groove Diameter D ₁ h8	Groove Width L ₁ +0.15	TSS Part No.	O-ring Sizes
65.0	57.5	3.80	APG200650	56.74 x 3.53
67.0*	54.5	5.60	APG300670	53.34 x 5.33
68.0	60.5	3.80	APG200680	59.92 x 3.53
70.0	62.5	3.80	APG200700	59.92 x 3.53
70.0*	57.5	5.60	APG300700	56.52 x 5.33
72.0*	59.5	5.60	APG300720	56.52 x 5.33
75.0	67.5	3.80	APG200750	66.27 x 3.53
75.0*	62.5	5.60	APG300750	59.69 x 5.33
76.2	68.7	3.80	APG200762	66.27 x 3.53
78.0	70.5	3.80	APG200780	69.44 x 3.53
80.0*	67.5	5.60	APG300800	66.04 x 5.33
82.0*	69.5	5.60	APG300820	69.22 x 5.33
82.5	70.0	5.60	APG300825	69.22 x 5.33
85.0*	72.5	5.60	APG300850	72.39 x 5.33
90.0*	77.5	5.60	APG300900	75.57 x 5.33
92.0*	79.5	5.60	APG300920	78.74 x 5.33
95.0*	82.5	5.60	APG300950	81.92 x 5.33
100.0*	87.5	5.60	APG301000	85.09 x 5.33
101.6	89.1	5.60	APG301016	88.27 x 5.33
102.0*	89.5	5.60	APG301020	88.27 x 5.33
105.0*	92.5	5.60	APG301050	91.44 x 5.33
108.0*	95.5	5.60	APG301080	94.62 x 5.33
110.0*	97.5	5.60	APG301100	94.62 x 5.33
115.0*	102.5	5.60	APG301150	100.97 x 5.33
118.0*	105.5	5.60	APG301180	104.14 x 5.33
120.0*	107.5	5.60	APG301200	107.32 x 5.33
125.0*	112.5	5.06	APG301250	110.49 x 5.33
127.0	114.5	5.60	APG301270	113.67 x 5.33
130.0	117.5	5.60	APG301300	116.84 x 5.33
130.0*	115.0	7.55	APG401300	113.67 x 7.00
133.0	118.0	7.55	APG401330	116.84 x 7.00
135.0*	120.0	7.55	APG401350	120.02 x 7.00
137.0*	122.0	7.55	APG401370	120.02 x 7.00
140.0*	125.0	7.55	APG401400	123.19 x 7.00
143.0*	128.0	7.55	APG401430	126.37 x 7.00
145.0*	130.0	7.55	APG401450	129.54 x 7.00
150.0*	135.0	7.55	APG401500	132.72 x 7.00
152.4	137.4	7.55	APG401524	135.89 x 7.00
153.0*	138.0	7.55	APG401530	135.89 x 7.00
155.0*	140.0	7.55	APG401550	139.07 x 7.00
160.0*	145.0	7.55	APG401600	142.24 x 7.00
165.0*	150.0	7.55	APG401650	148.59 x 7.00
170.0*	155.0	7.55	APG401700	151.77 x 7.00
175.0	160.0	7.55	APG401750	158.12 x 7.00
180.0	165.0	7.55	APG401800	164.47 x 7.00

Piston Seal - Type APG



Rod D _N H9	Groove Diameter D ₁ h8	Groove Width L ₁ +0.15	TSS Part No.	O-ring Sizes
180.0*	162.0	7.55	APG801800	158.12 x 7.00
185.0*	167.0	7.55	APG801850	164.47 x 7.00
190.0*	175.0	7.55	APG401900	170.82 x 7.00
194.0	179.0	7.55	APG401940	177.17 x 7.00
195.0*	177.0	7.55	APG801950	177.17 x 7.00
200.0	185.0	7.55	APG402000	183.52 x 7.00
200.0*	182.0	7.55	APG802000	177.17 x 7.00
203.2	188.2	7.55	APG402032	183.52 x 7.00
205.0	190.0	7.55	APG402050	189.87 x 7.00
210.0*	192.0	7.55	APG802100	189.87 x 7.00
210.0	195.0	7.55	APG402100	189.87 x 7.00
215.0	200.0	7.55	APG402150	196.22 x 7.00
215.0*	197.0	7.55	APG802150	196.22 x 7.00
220.0	205.0	7.55	APG402200	202.57 x 7.00
220.0*	202.0	7.55	APG802200	202.57 x 7.00
230.0	215.0	7.55	APG402300	215.27 x 7.00
240.0	225.0	7.55	APG402400	227.97 x 7.00
250.0	232.0	7.55	APG802500	227.97 x 7.00
254.0	236.0	7.55	APG802540	227.97 x 7.00
255.0	237.0	7.55	APG802550	227.97 x 7.00
260.0	242.0	7.55	APG802600	240.67 x 7.00
265.0	247.0	7.55	APG802650	240.67 x 7.00
268.0	250.0	7.55	APG802680	240.67 x 7.00
270.0	252.0	7.55	APG802700	253.37 x 7.00
280.0	262.0	7.55	APG802800	253.37 x 7.00
290.0	272.0	7.55	APG802900	266.07 x 7.00
300.0	282.0	7.55	APG803000	278.77 x 7.00
304.8	286.8	7.55	APG803048	278.77 x 7.00
310.0	292.0	7.55	APG803100	291.47 x 7.00
320.0	302.0	7.55	APG803200	304.17 x 7.00
330.0	312.0	7.55	APG803300	304.17 x 7.00
350.0	332.0	7.55	APG803500	329.57 x 7.00
354.9	336.9	7.55	APG803549	329.57 x 7.00
400.0	382.0	7.55	APG804000	380.37 x 7.00
425.0	407.0	7.55	APG804250	405.26 x 7.00
450.0	432.0	7.55	APG804500	430.66 x 7.00
475.0	457.0	7.55	APG804750	456.06 x 7.00
500.0	482.0	7.55	APG805000	481.38 x 7.00
525.0	507.0	7.55	APG805250	506.86 x 7.00
550.0	532.0	7.55	APG805500	532.26 x 7.00
575.0	557.0	7.55	APG805750	557.66 x 7.00
600.0	582.0	7.55	APG806000	582.68 x 7.00
650.0	632.0	7.55	APG806500	633.48 x 7.00
700.0	682.0	7.55	APG807000	681.51 x 7.00
750.0	732.0	7.55	APG807500	731.51 x 7.00

Rod D _N H9	Groove Diameter D ₁ h8	Groove Width L ₁ +0.15	TSS Part No.	O-ring Sizes
800.0	782.0	7.55	APG808000	781.51 x 7.00
850.0	832.0	7.55	APG808500	831.51 x 7.00
900.0	882.0	7.55	APG809000	881.51 x 7.00
950.0	932.0	7.55	APG809500	931.51 x 7.00
999.9	981.90	7.55	APG809999	981.41 x 7.00

* Standard diameter for Turcon® Glyd Ring® PG59

Other dimensions and all intermediate sizes up to 999.9 mm diameter can be supplied.

For bore diameters >999.9 mm and up to 2.700 mm use the RG46 series Turcon® Glyd Ring®.

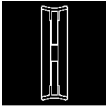

Complete piston - Type AK

■ Piston seal type AK

Description

Ready-to-install double acting piston with integrated metal disc and sealing lips. The rubber cover on the sides of the metal disc has air channels to ensure pressure application on the full piston surface.

Technical data

- Operating pressure: 1.2 MPa
- Speed: <=1 m/s
- Temperature: -30 °C ... +100 °C (other temperature ranges on request)
- Media: oil free air (initial grease lubrication required), lubricated air, nonagressive gases

Material

Standard Material: Material combination NBR 70 Shore A / carbon steel 1.0315 (fully rubber covered).
Material No.: N7MM

Installation

Ready-to-install piston to be pushed onto the end of the rod and fixed with a nut.

Ordering example

Piston Seal
 type AK
 Bore diameter: D = 63.0 mm
 Outside diameter: d = 16.0 mm
 Ring width: B = 22 mm
 TSS Part No.: AK1606322 (Table XXVI)
 Material No.: N7MM

TSS Article No.	AK	160	63	22	-	N7MM
TSS Series No.						
Piston diameter x 10						
Bore diam. / Ring width						
Material Code						

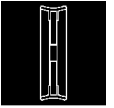

Installation recommendation, type AK

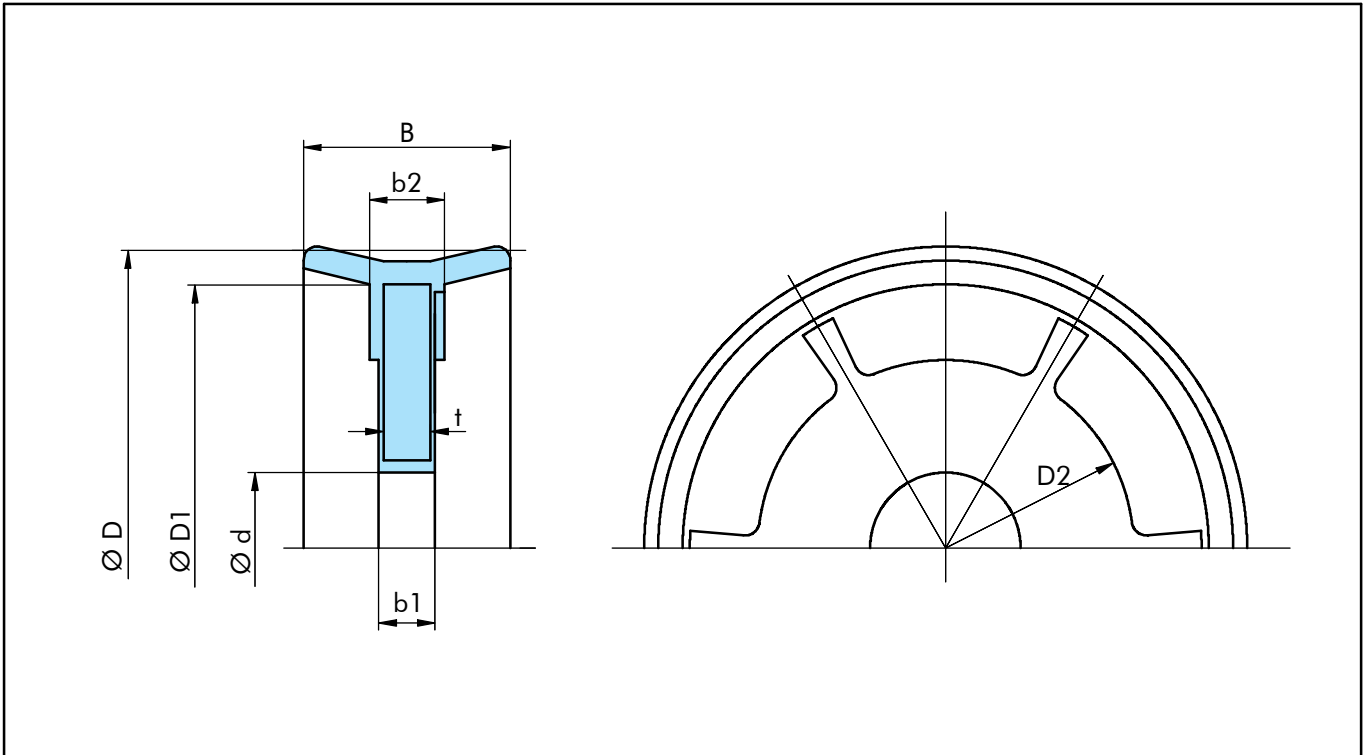

Figure 11 Installation dimensions

Table XXVI Range of sizes

Bore diameter	Insider diameter	Ring width			Thickness	Diameter		TSS Article No.
		B	b1	b2		D1	D2	
25.0	8.0	12.0	3.6	6.0	3.0	21.0	16.0	AK0802512 AK0803215 AK1004018
32.0	8.0	15.0	3.6	6.0	3.0	27.5	16.0	
40.0	10.0	18.0	4.6	7.0	4.0	35.0	23.0	
50.0	10.0	18.0	4.6	7.0	4.0	45.0	25.0	AK1005018 AK1606322 AK1608024
63.0	16.0	22.0	5.6	8.0	5.0	57.0	40.0	
80.0	16.0	24.0	5.6	8.0	5.0	73.0	55.0	
100.0	20.0	26.0	6.6	10.0	6.0	92.5	72.0	AK2010026 AK2012526 AK2214028
125.0	20.0	26.0	7.4	10.0	6.0	116.0	90.0	
140.0	22.0	28.0	6.6	10.5	6.0	127.0	100.0	
160.0	27.0	30.0	9.5	11.5	8.0	149.5	110.0	AK2715030 AK2720035
200.0	27.0	35.0	12.0	15.0	10.0	183.0	150.0	

Sizes other than those listed above can also be manufactured on request.



Piston Seal - Type ARS

■ Piston seal type ARS

Description

A seal-scraper perfectly suited for high temperature pneumatic applications and applications with aggressive media, made from FKM as rubber metal bonded seal.

The ARS seal-scraper offers exceptionally high operational performance and strength. The design allows easy assembly into open grooves and is fixed by a circlip.

Assembly space equal to ARAA, ARAN and ARV items.

Technical data

- Operating pressure: 1.6 MPa
- Speed: <= 1 m/s
- Temperature: -15 °C to + 150 °C
- Media: oil free air (initial grease lubrication required), lubricated air, nonaggressive gases

Material

- Standard Material: FKM, 75 Shore A, colour brown
Material No.: VC4VR
- Special elastomer on the basis of FKM with an integrated vulcanised steel supporting disk.
- A circlip according DIN 7993 vers. B for fixing the seal in the groove included in delivery.

Installation

Installation into open groove and fixation with a circlip. If there is a removal notch the ARS-seal-scraper may be exchanged without removing the piston rod.

Ordering example

- Piston Seal type ARS
- Rod diameter: D = 50 mm
- Groove width: L = 10.4 mm
- TSS Part No.: ARS00500 (Table XXVII)
- Material No.: VC4VR

TSS Article No.	ARS00	0500	-	VC4VR
TSS Series No.				
Piston diameter x 10				
Material Code				



Installation recommendation type ARS

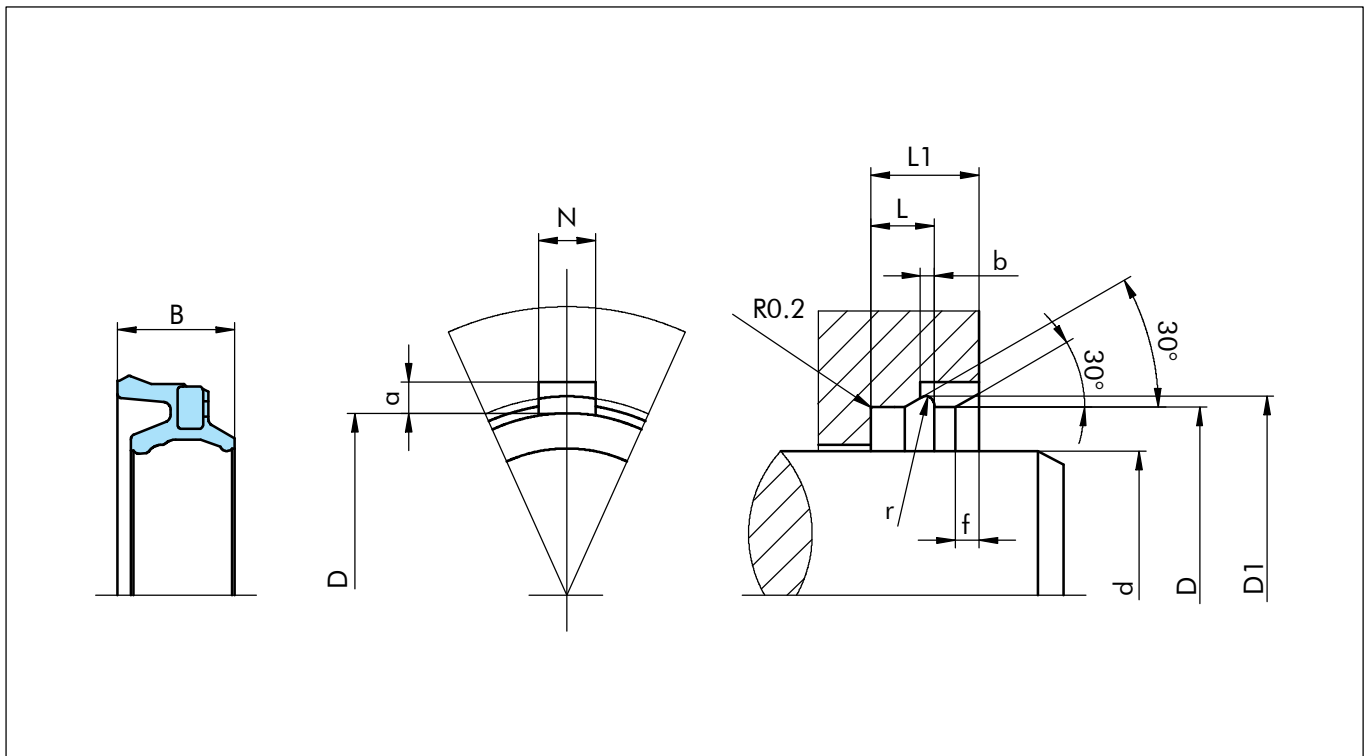

Figure 12 Installation drawing

Table XXVII Range of sizes

Rod diameter	Groove dimensions									Ring width	TSS Part No.
	d e9	D H10	$D1$ H10	$L1$ +0.5	L +0.25	b	r	a	N		
12.0	22.0	24.0	13.0	8.8	2.2	1.1	1.8	4.0	1.5	9.0	ARS000120
16.0	26.0	28.0	13.0	8.8	2.2	1.1	1.8	5.0	1.5	9.0	ARS000160
20.0	30.0	32.0	13.0	8.8	2.2	1.1	1.8	5.0	1.5	9.0	ARS000200
25.0	35.0	37.5	14.0	9.4	2.8	1.4	2.0	7.5	2.0	9.0	ARS000250
32.0	42.0	44.5	14.0	9.4	2.8	1.4	2.0	7.5	2.0	9.0	ARS000320
40.0	50.0	52.5	14.0	9.4	2.8	1.4	2.0	7.5	2.0	9.0	ARS000400
50.0	60.0	63.2	15.0	10.4	3.6	1.8	2.5	10.0	2.0	9.0	ARS000500
63.0	75.0	78.2	16.0	11.4	3.6	1.8	2.5	10.0	2.0	10.0	ARS000630



Seal-Scraper - Type AWNS

Seal-Scraper type AWNS

Description

Asymmetric lip seal with sealing lip and scraper lip. Small groove dimensions and double function allow space and cost savings.

Technical data

Operating pressure: 1.6 MPa

Speed: ≤ 1 m/s

Temperature: from -40 °C to +80 °C

Media: oil free air (initial grease lubrication required), lubricated air, nonaggressive gas

Material

Standard polyurethane with fair performance level.

Standard Material: Polyurethane, 90 Shore A, Material No.: WU9E1

Installation

Installation into split grooves or in closed grooves (above rod diameter 12). It is important to remove all sharp edges and burrs from the groove and rod before installation.

Ordering example

Seal-scraper,
type AWNS
Rod diameter: d = 20 mm
Groove width: L = 7 mm
TSS Part No.: AWNS10200 (Table XXVIII)
Material No. WU9E1

TSS Article No.	AWNS1	0200	-	WU9E1
TSS Series No.				
Rod diameter x 10				
Material Code				



Installation recommendation, type AWNS

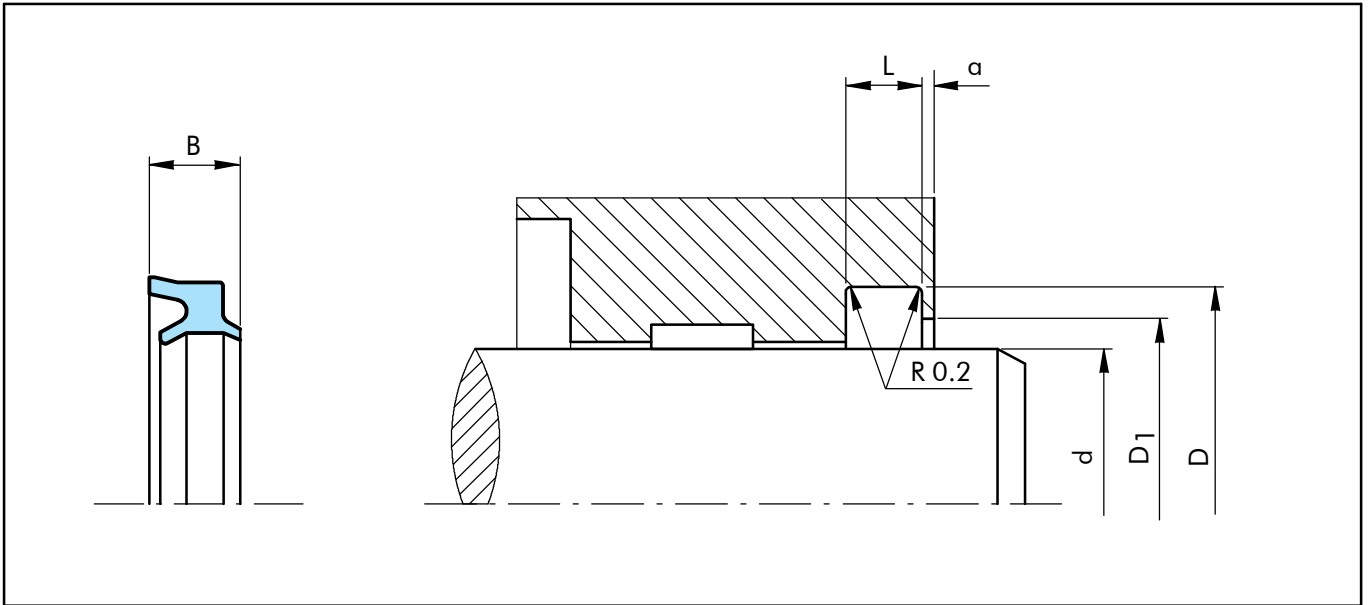

Figure 13 Installation drawing

Table XXVIII Installation dimensions / TSS Part No.

Rod diameter	Groove diameter	Groove width	Coupler diameter	Ring width	Step width	TSS Part No.
$d f7$	$D H10$	$L +0.15$	$D_1 H11$	B	$\min a+0.1$	
3.0	8.8	4.5	5.0	5.2	1.2	AWNS00030
4.0	8.8	4.5	6.0	5.2	1.2	AWNS00040
4.0	7.0	2.7	5.4	2.8	1.0	AWNS10040
5.0	8.0	2.7	6.2	2.8	1.0	AWNS00050
6.0	9.0	2.7	7.2	2.8	1.0	AWNS10060
6.0	10.8	4.5	8.0	5.2	1.2	AWNS00060
8.0	11.5	3.0	9.2	3.2	1.0	AWNS10080
8.0	12.8	4.5	10.0	5.2	1.2	AWNS00080
8.0	14.0	4.5	11.0	5.2	1.2	AWNS20080
10.0	14.0	3.2	11.4	3.7	1.0	AWNS10100
10.0	16.0	4.0	12.5	4.6	1.0	AWNS20100
10.0	16.8	4.5	13.0	5.2	1.2	AWNS00100
10.0	18.0	5.0	14.0	6.0	1.6	AWNS30100
12.0	16.5	3.7	13.7	4.0	1.2	AWNS40120
12.0	18.0	4.0	14.5	4.8	1.2	AWNS00120
12.0	20.0	3.7	16.0	5.7	1.6	AWNS60120
12.0	20.0	5.0	16.0	6.0	1.6	AWNS10120
12.0	20.0	5.5	16.0	6.5	1.6	AWNS20120
12.0	22.0	6.0	16.0	6.5	1.5	AWNS30120
14.0	18.5	3.7	15.7	4.0	1.2	AWNS20140
14.0	20.0	4.0	16.5	4.8	1.2	AWNS00140
14.0	22.0	5.0	18.0	6.0	1.5	AWNS30140



Seal-Scraper - Type AWNS

Rod diameter	Groove diameter	Groove width	Coupling diameter	Ring width	Step width	TSS Part No.
d f7	D H 10	L +0.15	D ₁ H11	B	min a+0.1	
14.0	24.0	6.0	18.0	6.5	1.5	AWNS10140
15.0	22.0	4.0	18.0	5.0	1.5	AWNS00150
16.0	20.5	3.7	17.7	4.0	1.2	AWNS20160
16.0	22.0	4.0	18.5	5.0	1.2	AWNS00160
16.0	24.0	5.0	18.5	6.0	1.5	AWNS30160
16.0	26.0	6.0	20.0	6.5	1.5	AWNS10160
18.0	22.5	3.7	19.7	4.0	1.2	AWNS10180
18.0	24.0	4.0	20.5	5.0	1.4	AWNS20180
18.0	26.0	5.0	21.0	6.0	1.6	AWNS30180
18.0	28.0	6.0	22.0	6.5	1.5	AWNS00180
20.0	25.0	4.0	21.9	4.6	1.2	AWNS20200
20.0	26.0	4.0	22.5	4.8	1.2	AWNS00200
20.0	30.0	7.0	24.0	7.5	1.5	AWNS10200
22.0	27.0	4.0	23.9	4.6	1.2	AWNS00220
22.0	28.0	4.0	24.5	5.0	1.4	AWNS10220
22.0	32.0	7.0	26.0	7.5	1.5	AWNS20220
25.0	30.0	4.0	26.9	4.6	1.2	AWNS20250
25.0	31.0	4.0	27.5	4.8	1.2	AWNS00250
25.0	35.0	7.0	29.0	7.5	1.5	AWNS10250
28.0	38.0	7.0	32.0	7.5	1.5	AWNS00280
30.0	35.5	4.55	32.1	5.0	1.2	AWNS10300
30.0	38.0	5.0	33.0	5.8	1.5	AWNS20300
30.0	40.0	7.0	34.0	7.5	1.5	AWNS00300
32.0	37.5	4.55	34.1	5.0	1.2	AWNS20320
32.0	40.0	5.0	35.0	5.8	1.3	AWNS10320
32.0	42.0	7.0	36.0	7.5	1.5	AWNS00320
35.0	45.0	7.0	39.0	7.5	1.5	AWNS00350
36.0	44.0	5.0	39.0	6.0	1.3	AWNS00360
36.0	46.0	7.0	40.0	7.5	1.5	AWNS10360
40.0	46.0	4.9	42.2	5.5	1.4	AWNS10400
40.0	50.0	7.0	44.0	7.5	1.5	AWNS00400
45.0	53.0	5.0	48.0	6.0	1.3	AWNS00450
45.0	55.0	7.0	49.0	7.5	1.5	AWNS10450
50.0	62.0	8.5	55.0	9.0	2.0	AWNS00500
70.0	80.0	6.0	75.0	7.0	1.5	AWNS00700



■ Seal-scraper type AWSD

Description

Asymmetric lip seal with sealing lip and scraper lip. Small groove dimensions and double function allow space and cost savings. Special design facilitates installation especially for small diameters.

Technical data

Operating pressure: 1.6 MPa
 Speed: ≤ 1 m/s
 Temperature: from -40 °C to +80 °C
 Media: oil free air (initial lubrication required), lubricated air, nonaggressive gases

Material

Standard polyurethane with fair performance level.
 Standard Material: Polyurethane, 90 Shore A,
 Material No.: WU9E1

Installation

Installation into split grooves or in closed grooves. It is important to remove all sharp edges and burrs from the groove and rod before installation.

Attention

For all rod diameters above 20 mm, we recommend only the groove design with oversized step (type L₁ in Fig.14, page 39).

Ordering example

Rod wiper,
 type AWSD
 Rod diameter: d = 20 mm
 Groove width: L = 4 mm
 TSS Part No.: AWSD00200 (Table XXIX)
 Material No.: WU9E1

TSS Article No.	AWSD0	0200	-	WU9E1
TSS Series No.				
Rod diameter x 10				
Material Code				



Seal-Scraper - Type AWS D

Installation recommendation, type AWS D

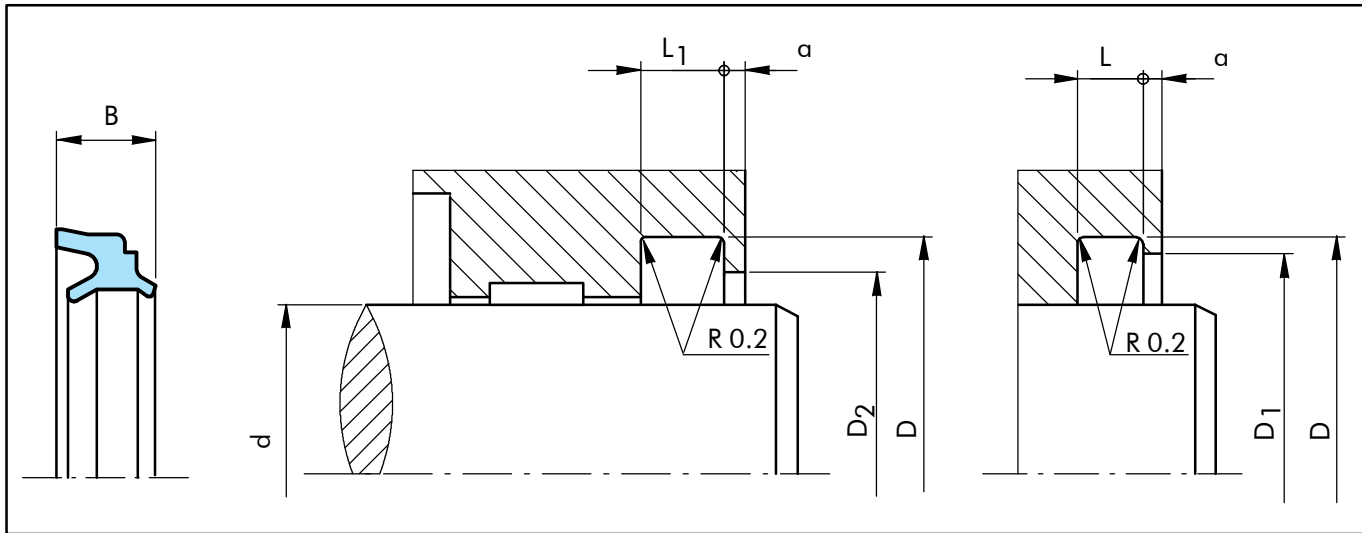

Figure 14 Installation Drawing

Table XXIX Installations dimensions / TSS Part No.

Rod diameter	Groove diameter	Groove width	Groove width	Tooth width	Step diameter	Step diameter	Ring width	TSS Part No.
d_{e9}	D_{H10}	$L_{+0.15}$	$L_{1+0.15}$	$a_{+0.1}$	$D_{1 H11}$	$D_{2 H11}$	B	
4.0	8.1	3	3.8	0.8	6.7	6.1	4.0	AWSD00040
6.0	11.1	3.6	4.6	1.0	9.1	8.5	5.0	AWSD00060
8.0	14.1	3.6	4.6	1.0	12.1	11.1	5.0	AWSD00080
10.0	16.1	4.2	5.4	1.2	14.1	13.1	6.0	AWSD00100
12.0	18.1	4.2	5.4	1.2	15.5	14.9	6.0	AWSD00120
12.0	20.0	4.0	6.0	2.0	18.0	15.5	8.0	AWSD10120
16.0	24.0	4.0	6.0	2.0	22.0	19.5	8.0	AWSD00160
18.0	26.0	4.0	6.0	2.0	24.0	21.5	8.0	AWSD00180
20.0	28.0	4.0	6.0	2.0	26.0	23.5	8.0	AWSD00200
25.0	33.0	4.0	6.0	2.0	31.0	28.5	8.0	AWSD00250
28.0	36.0	4.0	6.0	2.0	34.0	31.5	8.0	AWSD00280
30.0	38.0	4.0	6.0	2.0	36.0	33.5	8.0	AWSD10300
32.0	40.0	4.0	6.0	2.0	38.0	35.5	8.0	AWSD00320
35.0	43.0	4.0	6.0	2.0	41.0	38.5	8.0	AWSD00350
36.0	44.0	4.0	6.0	2.0	42.0	39.5	8.0	AWSD00360
40.0	48.0	4.0	6.0	2.0	46.0	43.5	8.0	AWSD00400
42.0	50.0	4.0	6.0	2.0	48.0	45.5	8.0	AWSD00420
45.0	53.0	4.0	6.0	2.0	51.0	48.5	8.0	AWSD00450
50.0	58.0	4.0	6.0	2.0	56.0	53.5	8.0	AWSD00500
55.0	63.0	4.0	6.0	2.0	61.0	58.5	8.0	AWSD00550
56.0	64.0	4.0	6.0	2.0	62.0	59.5	8.0	AWSD00560

Seal-Scraper - Type AWSD



Rod diameter	Groove diameter	Groove width	Groove width	Step width	Coupling diameter	Coupling diameter	Ring width	TSS Part No.
d_{e9}	D_{H10}	$L_{+0.15}$	$L_1_{+0.15}$	$a_{+0.1}$	D_1_{H11}	D_2_{H11}	B	
60.0	68.0	4.0	6.0	2.0	66.0	63.5	8.0	AWSD00600
63.0	71.0	4.0	6.0	2.0	69.0	66.5	8.0	AWSD00630
65.0	73.0	4.0	6.0	2.0	71.0	68.5	8.0	AWSD00650
70.0	78.0	4.0	6.0	2.0	76.0	73.5	8.0	AWSD00700
75.0	83.0	4.0	6.0	2.0	81.0	78.5	8.0	AWSD00750
80.0	88.0	4.0	6.0	2.0	86.0	83.5	8.0	AWSD00800
85.0	93.0	4.0	6.0	2.0	91.0	88.5	8.0	AWSD00850
90.0	98.0	4.0	6.0	2.0	96.0	93.5	8.0	AWSD00900
100.0	108.0	4.0	6.0	2.0	106.0	103.5	8.0	AWSD01000



Seal-Scraper - Type ARAA

Seal-Scraper type ARAA

Description

Rod seal-scraper with integrated fixing capability. Compared to ARAN improved in seal-lip design for better sealing and scraping performance. Very good protection against dirt ingress.

Assembly space equal to ARAN, ARS and ARV items.

This particular polyurethane offers exceptional wear resistance and extremely high operating performance. Special lip design for pneumatic application to maintain lubricating film and minimize friction.

For high humidity applications an alternative material with improved hydrolysis resistance is available.

Technical data

- Operating pressure: 1.6 MPa
- Speed: ≤ 1 m/s
- Temperature: -35 °C to + 110 °C
- Media: oil free air (initial grease lubrication required), lubricated air, nonaggressive gases

Material

Standard Material: Zurcon® PU, 94 Shore A, colour turquoise
Material No.: Z20

Installation

The ARAA-seal-scraper snaps into a special groove. Separate fixing elements are not necessary. It is important to remove all sharp edges from the groove and shaft to prevent damaging the seal / seal lips. Note: Avoid grease on outer diameter and groove.

Ordering example

Piston Seal
type ARAA
Rod diameter: D = 20 mm
Groove width: L = 8.8 mm
TSS Part No.: ARAA00200 (Table XXX)
Material No.: Z20

TSS Article No.	ARAA0	0200	-	Z20
TSS Series No.				
Piston diameter x 10				
Material Code				



Installation recommendation, type ARAA

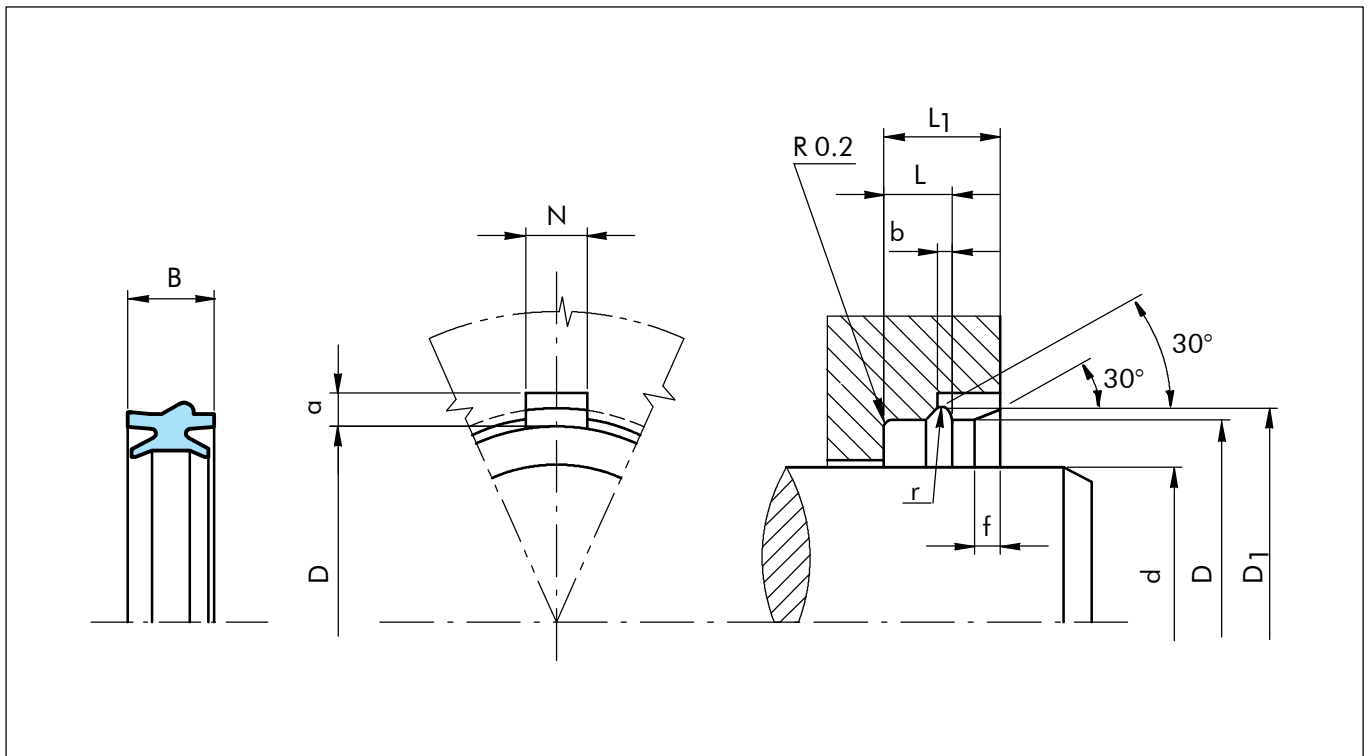

Figure 15 Installation drawing

Table XXX Range of sizes

Rod diameter	Groove dimensions									Ring width	TSS Part No.
	D H10	D1 H10	L1 +0.5	L +0.25	b	r	a	N	f		
12.0	22.0	24.0	13.0	8.8	2.2	1.1	1.8	4.0	1.5	10.7	ARAA10120
16.0	26.0	28.0	13.0	8.8	2.2	1.1	1.8	5.0	1.5	10.7	ARAA00160
20.0	30.0	32.0	13.0	8.8	2.2	1.1	1.8	5.0	1.5	10.7	ARAA00200
25.0	35.0	37.5	14.0	9.4	2.8	1.4	2.0	7.5	2.0	11.2	ARAA00250
32.0	42.0	44.5	14.0	9.4	2.8	1.4	2.0	7.5	2.0	11.2	ARAA00320



Seal-Scraper - Type ARAN

Seal-Scraper type ARAN

Description

Asymmetric lip seal with sealing lip and scraper lip. Very good protection against dirt ingress. Special groove and seal design allows fast installation either automatically or manually.

Assembly space equal to ARAA, ARS and ARV items.

Technical data

Operating pressure: 1.6 MPa

Speed: ≤ 1 m/s

Temperature: from -40 °C to +80 °C

Media: oil free air (initial grease lubrication required), lubricated air, nonaggressive gases

Material

Standard polyurethane with fair performance level.

Standard Material: Polyurethane, 90 Shore A, Material No.: WU9E1

Installation

The ARAN-seal-scraper snaps into a special groove. Separate fixing elements are not necessary. It is important to remove all sharp edges from the groove and shaft to prevent damaging the seal / seal lips. Note: Avoid grease on outer diameter and groove.

Ordering example

Rod wiper,
type ARAN
Rod diameter: $d = 20$ mm
Groove width: $L = 8.8$ mm
TSS Part No.: ARAN00200 (Table XXXI)
Material No.: WU9E1

TSS Article No.	ARAN0	0200	-	WU9E1
TSS Series No.				
Rod diameter x 10				
Material No.:				



Installation recommendation type ARAN

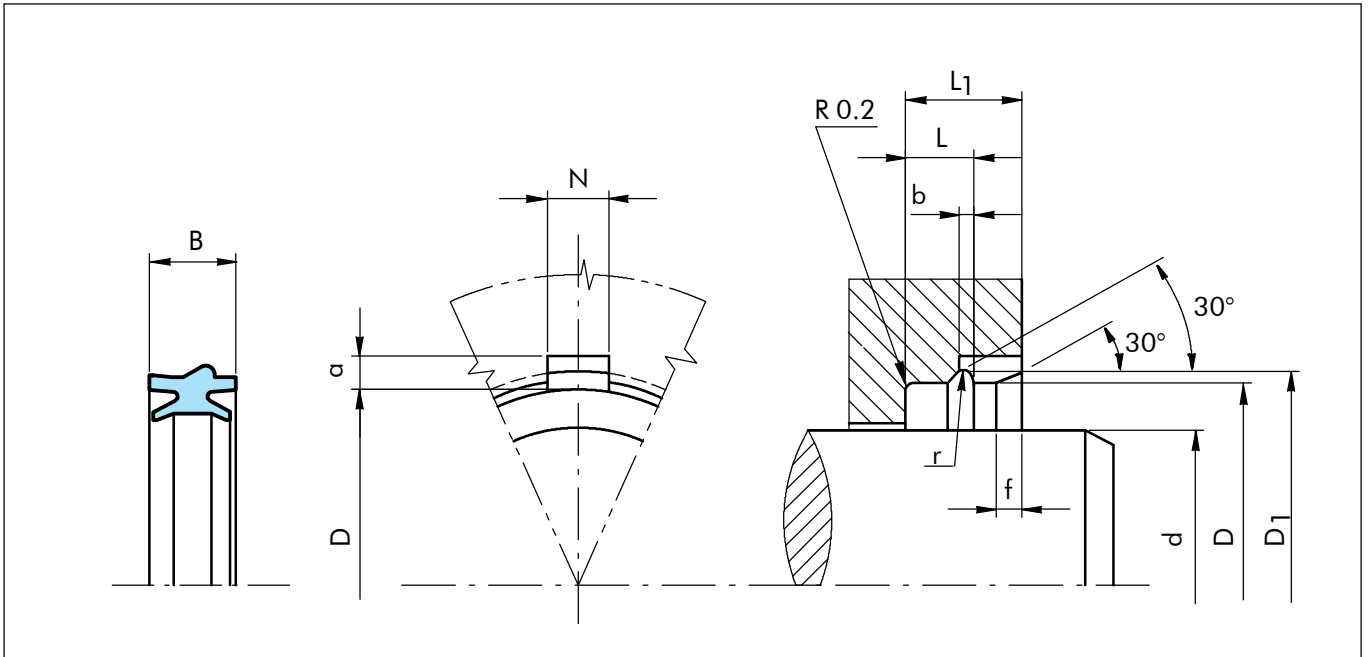

Figure 16 Installation drawing

Table XXXI Installation dimensions / TSS Part No.

Rod diameter	Groove dimensions									Ring width	TSS Part No.
	D H10	D ₁ H10	L ₁ +0.5	L+0.25	b	r	a	N	f		
12.0	20.0	22.0	13.0	8.8	2.2	1.1	1.8	4.0	1.5	10.7	ARAN00120
12.0	22.0	24.0	13.0	8.8	2.2	1.1	1.8	4.0	1.5	10.7	ARAN10120
16.0	26.0	28.0	13.0	8.8	2.2	1.1	1.8	5.0	1.5	10.7	ARAN00160
18.0	26.0	28.0	13.0	8.8	2.2	1.1	1.8	5.0	1.5	10.7	ARAN00180
18.0	28.0	30.0	13.0	8.8	2.2	1.1	1.8	5.0	1.5	10.7	ARAN10180
20.0	30.0	32.0	13.0	8.8	2.2	1.1	1.8	5.0	1.5	10.7	ARAN00200
22.0	32.0	34.5	14.0	9.4	2.8	1.4	2.0	7.5	2.0	11.2	ARAN00220
25.0	35.0	37.5	14.0	9.4	2.8	1.4	2.0	7.5	2.0	11.2	ARAN00250
30.0	40.0	42.5	14.0	9.4	2.8	1.4	2.0	7.5	2.0	11.2	ARAN00300
32.0	42.0	44.5	14.0	9.4	2.8	1.4	2.0	7.5	2.0	11.2	ARAN00320
40.0	50.0	52.5	14.0	9.4	2.8	1.4	2.0	7.5	2.0	11.2	ARAN00400
45.0	55.0	58.2	15.0	10.4	3.6	1.8	2.5	10.0	2.0	12.2	ARAN00450
50.0	60.0	63.2	15.0	10.4	3.6	1.8	2.5	10.0	2.0	12.2	ARAN00500



Scraper - Type AWSW

■ Scraper type AWSW

Description

Single acting scraper for use with separate rod seal. Special lip design for pneumatic application to maintain rod lubrication.

Technical data

Operating pressure: -

Speed: ≤ 1 m/s

Temperature: from -40 °C to +80 °C

Media: oil free air (initial grease lubrication required), lubricated air, nonaggressive gases

Material

Standard polyurethane with fair performance level.

Standard Material: Polyurethane, 90 Shore A, Material No.: WU9E1

Installation

In split grooves or in closed grooves. It is important to remove all sharp edges and burrs from the groove and rod before installation.

Ordering example

Rod wiper,
type AWSW
Rod diameter: d = 20 mm
Groove width: L = 4 mm
TSS Part No.: AWSW00200 (Table XXXII)
Material No.: WU9E1

TSS Article No.	AWSW0	0200	-	WU9E1
TSS Series No.				
Rod diameter x 10				
Material code:				



Installation recommendation, type AWSW

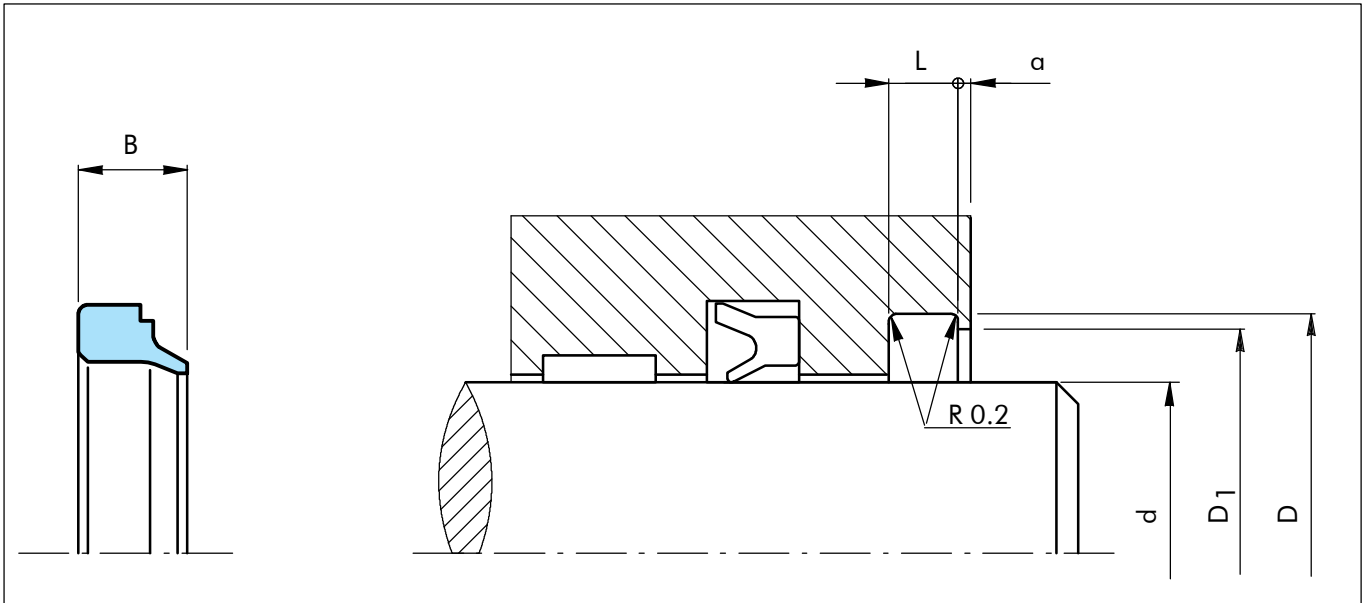

Figure 17 Installation drawing

Table XXXII Installation dimensions / TSS Part No.

Rod diameter	Groove diameter	Groove width	Coupling diameter	Step width	Ring width	TSS Part No.
d f7	D H11	$L + 0.15$	D_1 H11	a min.	B	
6.0	10.0	2.0	8.0	1.0	4.0	AWSW00060
8.0	14.0	2.5	12.0	1.0	5.0	AWSW00080
10.0	18.0	4.0	16.0	1.0	7.0	AWSW00100
10.0	16.0	2.5	14.0	1.0	5.0	AWSW10100
12.0	20.0	4.0	18.0	1.0	7.0	AWSW00120
12.0	18.0	2.5	16.0	1.0	5.0	AWSW10120
14.0	22.0	4.0	20.0	1.0	7.0	AWSW00140
14.0	20.0	2.5	18.0	1.0	5.0	AWSW10140
16.0	24.0	4.0	22.0	1.0	7.0	AWSW00160
18.0	26.0	4.0	24.0	1.0	7.0	AWSW00180
20.0	28.0	4.0	26.0	1.0	7.0	AWSW00200
22.0	30.0	4.0	28.0	1.0	7.0	AWSW00220
25.0	33.0	4.0	31.0	1.0	7.0	AWSW00250
28.0	36.0	4.0	34.0	1.0	7.0	AWSW00280
30.0	38.0	4.0	36.0	1.0	7.0	AWSW00300
32.0	40.0	4.0	38.0	1.0	7.0	AWSW00320
35.0	43.0	4.0	41.0	1.0	7.0	AWSW00350
38.0	46.0	4.0	44.0	1.0	7.0	AWSW00380
40.0	48.0	4.0	46.0	1.0	7.0	AWSW00400
45.0	53.0	4.0	51.0	1.0	7.0	AWSW00450
50.0	58.0	4.0	56.0	1.0	7.0	AWSW00500
55.0	63.0	4.0	61.0	1.0	7.0	AWSW00550
60.0	68.0	4.0	66.0	1.0	7.0	AWSW00600



Wipers for guiding units - Type AWBB

■ Wipers for guiding units, type AWBB

Description

Wiper specially designed for guide units with linear ball bearings. Wiper lip with minimal pre-load to avoid negative influences on the sliding behaviour of the guide unit. The outer diameter is designed for fixing by a standard circlip retainer groove.

The installation dimensions correspond to the housing diameter of the ball bearing.

Technical data

Operating pressure: -

Speed: ≤ 4 m/s

Temperature: from -40 °C to $+80$ °C

Material

Standard polyurethane with fair performance level.

Standard Material: Polyurethane, 90 Shore A,
Material No.: WU9E1

Installation

Installation by snapping the fixing collar into a standard circlip retainer groove.

It is important to remove all sharp edges and burrs from the groove and rod before installation.

Ordering example

Wiper,

type AWBB

Rod diameter: $d = 20$ mm

Groove width: $L = 1.6$ mm

TSS Part No.: AWBB00200 (Table XXIII)

Material No.: WU9E1

TSS Article No.	AWBB0	0200	-	WU9E1
TSS Series No.				
Rod diameter x 10				
Material code:				

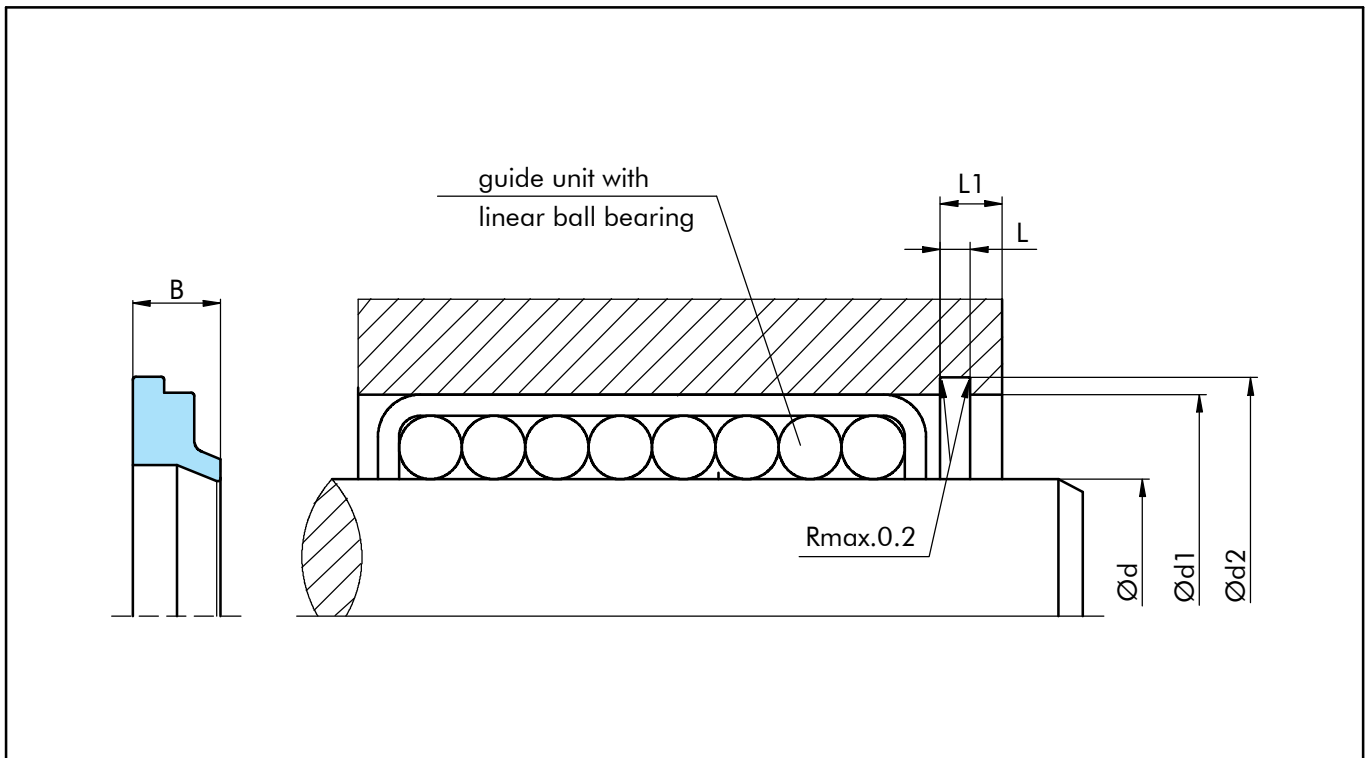

Figure 18 Installation drawing

Table XXXIII Range of sizes

Rod diameter	Groove dimensions				Ring width	TSS Part No.
	d e9	d_1 H10	d_2 H10	L_1 +0.1		
8.0	15.0	17.6	3.0	1.6	4.5	AWBB00080
10.0	17.0	19.6	3.0	1.6	4.5	AWBB00100
12.0	19.0	21.6	3.0	1.6	4.5	AWBB00120
14.0	21.0	23.6	3.0	1.6	4.5	AWBB00140
16.0	24.0	26.6	3.0	1.6	4.5	AWBB00160
20.0	28.0	30.6	3.0	1.6	4.5	AWBB00200
25.0	35.0	37.6	3.0	1.6	4.5	AWBB00250
30.0	40.0	42.6	3.0	1.6	4.5	AWBB00300
40.0	52.0	54.6	3.0	1.6	4.5	AWBB00400



Seal-Scraper - Type ARV

Seal-Scraper type ARV

Description

Asymmetric Variseal® type seal with spring energized sealing lip and scraper lip. Suitable for poor lubrication, high speed or foodstuff application (FDA compliant). Very good protection against dirt ingress. (Hi-Clean version available where the spring cavity of the scraper lip is filled with a Silicone gel preventing contaminants from being entrapped.)

Special groove and seal design allows fast installation either automatically or manually.

Technical data

Operating pressure: 1.6 MPa
Speed: <= 5 m/s
Temperature: -30 °C to +80 °C
other temperature ranges on request

Media: oil free air with or without initial grease lubrication, lubricated air, nonaggressive gases, foodstuff

Material

Standard Material: Ultra-high-molecular weight-polyethylene, 52 Shore D, colour white to off white
Material No.: Z80S

V-spring: standard materials AISI 301

Installation

Snap-in installation into open grooves.

It is important to remove all sharp edges and burrs from the groove and rod before installation. Note: Inlet chamfer on rod and bore diameter required.

Ordering example

Rod wiper,
type ARV

Rod diameter: d = 20 mm

Groove width: L = 8.8 mm

TSS Part No.: ARV00200 (Table XXXIV)

Material No.: Z80S

TSS Article No.	ARV00	0200	-	Z80S
TSS Series No.				
Rod diameter x 10				
Material No.:				
Material code for spring				



Installation recommendation type ARV

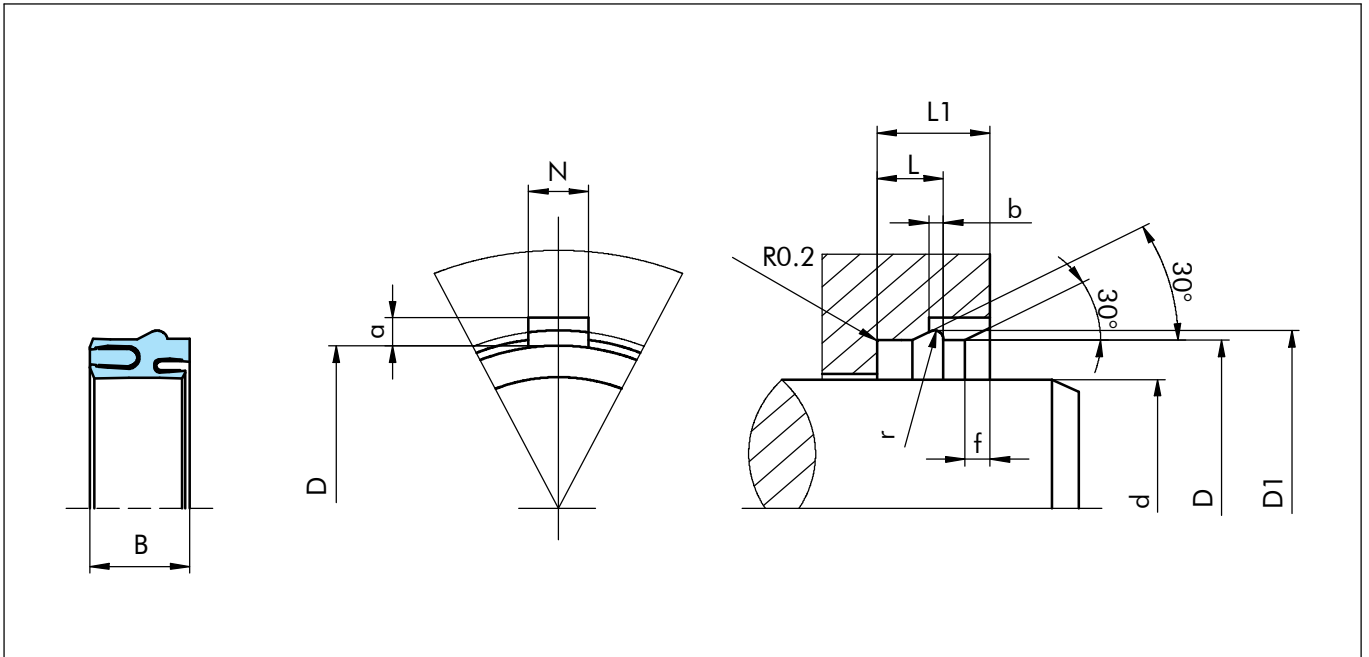

Figure 20 Installation drawing

Table XXXIV Installation dimensions / TSS Part No.

Rod diameter	Groove dimensions									Ring width	TSS Part No.
	d e9	D H10	D_1 H10	$L_1+0.5$	$L+0.25$	b	r	a	N		
10.0	18.0	20.0	12.0	7.7	2.2	1.1	1.8	4.0	1.5	10.7	ARV000100 ARV000120 ARV010120
12.0	20.0	22.0	13.0	8.8	2.2	1.1	1.8	4.0	1.5	10.7	
12.0	22.0	24.0	13.0	8.8	2.2	1.1	1.8	4.0	1.5	10.7	
14.0	24.0	26.0	13.0	8.8	2.2	1.1	1.8	5.0	1.5	10.7	ARV000140 ARV000160 ARV000180
16.0	26.0	28.0	13.0	8.8	2.2	1.1	1.8	5.0	1.5	10.7	
18.0	26.0	28.0	13.0	8.8	2.2	1.1	1.8	5.0	1.5	10.7	
18.0	28.0	30.0	13.0	8.8	2.2	1.1	1.8	5.0	1.5	10.7	ARV010180 ARV000200 ARV000220
20.0	30.0	32.0	13.0	8.8	2.2	1.1	1.8	5.0	1.5	10.7	
22.0	32.0	34.5	14.0	9.4	2.8	1.4	2.0	7.5	2.0	11.2	
25.0	35.0	37.5	14.0	9.4	2.8	1.4	2.0	7.5	2.0	11.2	ARV000250



Cushioning Seal - Type AICM

■ Cushioning seal, type AICM

Description

The cushioning seal AICM is designed especially for pneumatic cushioning where high pressure peaks occur. Effective cushioning due to lip sealing with inlet chamfer. After change of pressure direction, the integrated check valve function ensures pressure application on the full piston surface.

Technical data

Operating pressure:	1.6 MPa
Speed:	≤ 1 m/s
Temperature:	Z20 -35 °C to +110 °C WU9E1 -40 °C to +80 °C
Media:	oil free air (initial grease lubrication required), lubricated air, nonaggressive gases

Material

Standard:	Zurcon® PU, 94 Shore A, colour turquoise Material No.: Z20
-----------	---

* Available dimensions on request.

Alternative:	Standard polyurethane with fair performance level. Polyurethane, 90 Shore A, Material No.: WU9E1
--------------	--

Installation

Snap-in installation into closed grooves. It is important to remove all sharp edges and burrs from the groove and rod before installation.

Ordering example

Cushioning seal,
type AICM
Rod diameter: d = 20 mm
Groove width: L = 7 mm
TSS Part No.: AICM00200 (Table XXXV)
Material No.: Z20

TSS Article No.	AICM0	0200	-	Z20
TSS Series No.				
Rod diameter x 10				
Material Code				



Installation recommendation, type AICM

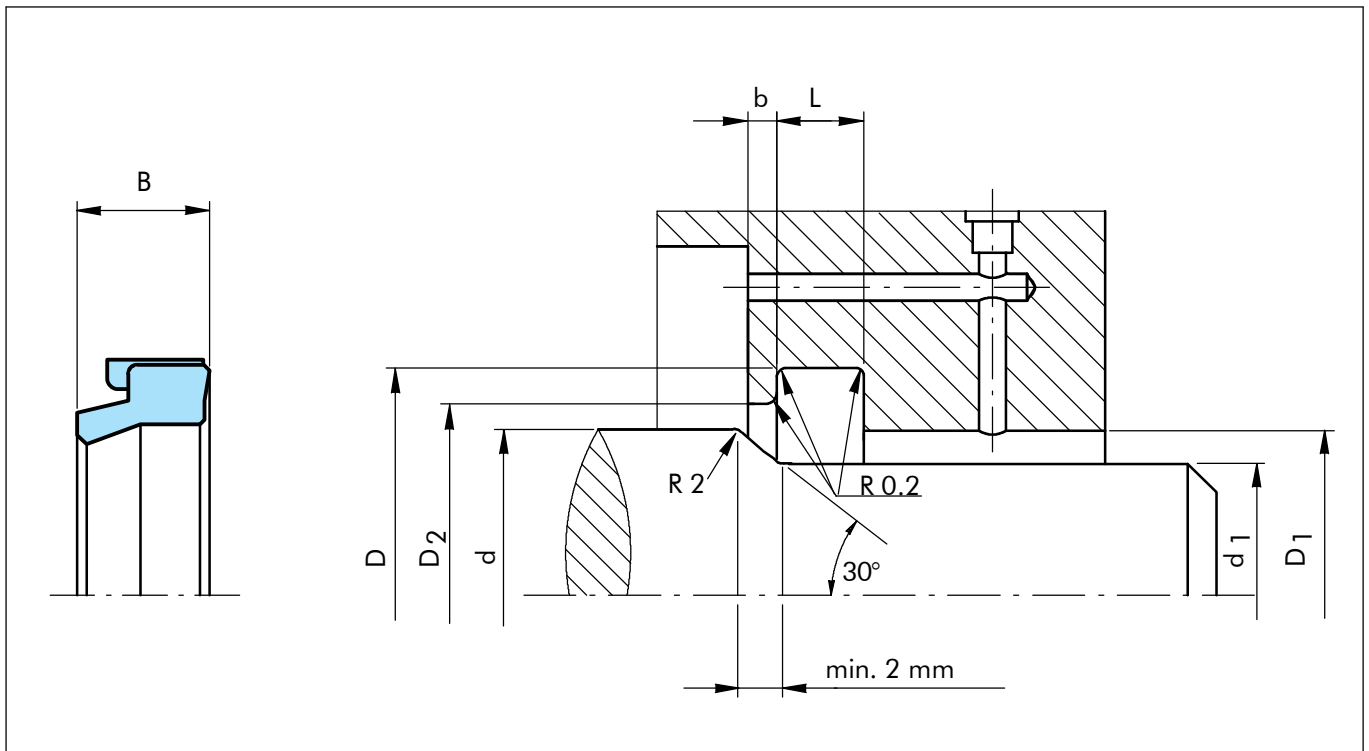

Figure 21 Installation drawing

Table XXXV Installation dimensions / TSS Part No.

Rod diameter d h10	Groove dimensions						Ring width B	TSS Part No.
	D H11	D₁ H11	D₂ H11	L ±0.1	d₁ h11	b +0.2		
6.0	10.0	6.5	8.0	3.7	4.5	2.0	4.0	AICM00060
8.0	11.6	8.5	10.0	3.3	7.0	2.0	3.5	AICM00080
9.5	15.0	10.0	12.0	4.5	8.0	2.0	4.5	AICM00095
10.0	18.0	11.0	15.0	7.0	8.0	2.0	7.8	AICM00100
12.0	18.0	13.0	15.5	4.8	10.0	2.0	5.0	AICM10120
12.0	20.0	13.0	17.0	7.0	10.0	2.0	7.8	AICM00120
14.0	22.0	15.0	19.0	7.0	12.0	2.0	7.8	AICM00140
16.0	22.0	17.0	19.5	5.2	14.0	2.0	5.5	AICM10160
16.0	24.0	17.0	21.0	7.0	14.0	2.0	7.8	AICM00160
18.0	26.0	19.0	23.0	7.0	16.0	2.0	7.8	AICM00180
20.0	28.0	21.0	24.0	7.0	17.5	2.0	7.8	AICM00200
22.0	30.0	23.0	26.0	7.0	19.5	2.0	7.8	AICM00220
25.0	33.0	26.0	29.0	7.0	22.5	2.0	7.8	AICM00250
28.0	36.0	29.0	32.0	7.0	25.5	2.0	7.8	AICM00280
30.0	40.0	31.5	35.0	7.0	27.5	2.0	7.8	AICM00300
32.0	42.0	33.5	37.0	7.0	29.0	2.0	7.8	AICM00320
36.0	46.0	37.5	41.0	7.0	33.0	2.0	7.8	AICM00360
40.0	50.0	41.5	45.0	7.0	37.0	2.0	7.8	AICM00400
50.0	60.0	51.5	55.0	7.0	47.0	2.0	7.8	AICM00500
57.0	74.0	60.0	65.0	12.5	54.0	2.0	11.0	AICM00570



Cushioning Seal - Type AIAS

■ Cushioning Seal, type AIAS

Description

The cushioning seal AIAS is designed especially for pneumatic cushioning where high pressure peaks occur. Small groove dimensions to replace O-rings. After change of pressure direction, the integrated check valve function ensures pressure application on the full piston surface.

Technical data

Operating pressure: 1.6 MPa

Speed: ≤ 1 m/s

Temperature: from -40 °C to +80 °C

Media: oil free air (initial grease lubrication required), lubeicated air, nonaggressive gases

Material

Standard polyurethane with fair performance level.

Standard Material: Polyurethane, 90 Shore A,
Material No.: WU9E1

Installation

Snap-in installation into closed grooves. It is important to remove all sharp edges and burrs from the groove and rod before installation.

Ordering example

Cushioning seal,
type AIAS
Rod diameter: d = 50 mm
Groove width: L = 6 mm
TSS Part No.: AIAS00500 (Table XXXVI)
Material No.: WU9E1

TSS Article No.	AIAS0	0500	-	WU9E1
TSS Series No.				
Rod diameter x 10				
Material Code				



Installation recommendation, type AIAS

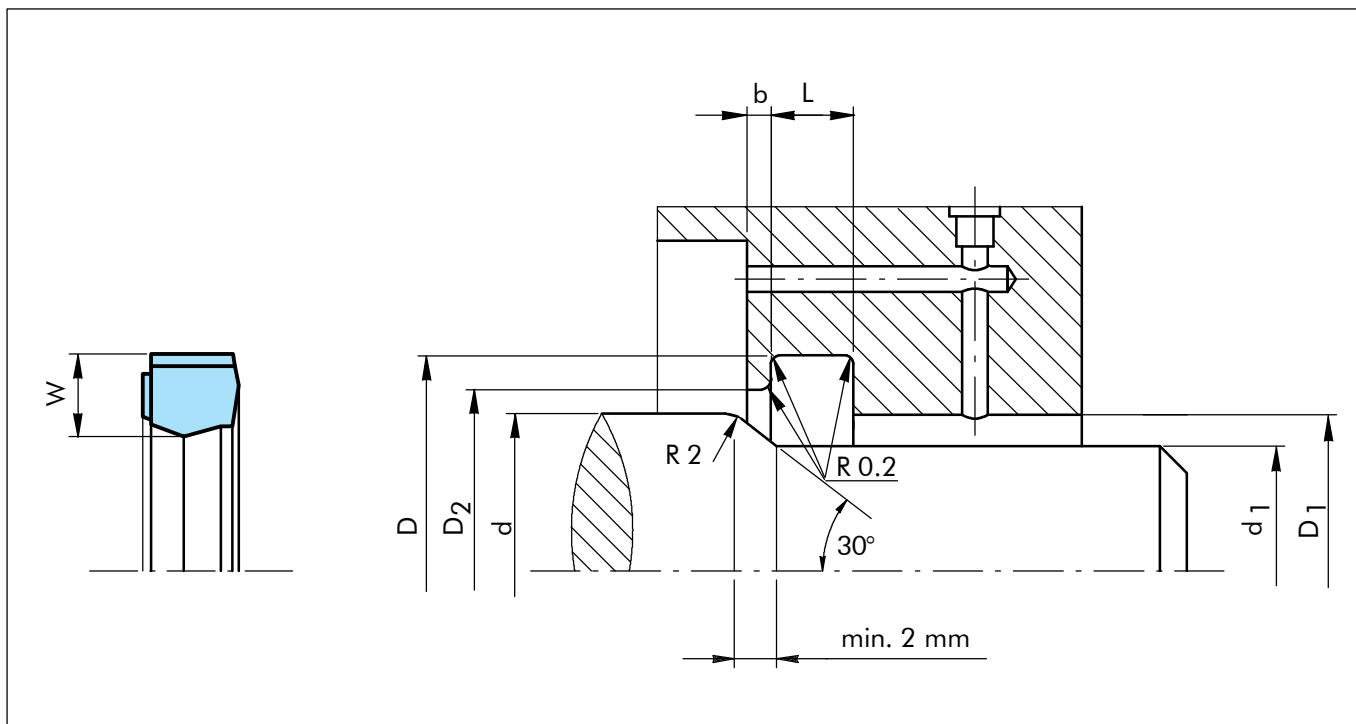

Figure 22 Installation drawing

Table XXXVI Installation dimensions / TSS Part No.

Rod diameter d h10	Groove dimensions						Ring width W	TSS Part No.
	D H11	D₁ H11	D₂ H11	L ±0.1	d₁ h11	b +0.2		
10.0	18.0	10.5	12.0	4.8	7.0	2.0	4.0	AIAS00100
12.0	20.0	12.5	14.0	4.8	9.0	2.0	4.0	AIAS00120
14.0	22.0	14.5	16.0	4.8	11.0	2.0	4.0	AIAS00140
16.0	24.0	16.5	18.0	4.8	13.0	2.0	4.0	AIAS00160
18.0	26.0	18.5	20.0	4.8	15.0	2.0	4.0	AIAS00180
20.0	28.0	20.5	22.0	4.8	17.0	2.0	4.0	AIAS00200
22.0	30.0	22.5	24.0	4.8	18.0	2.0	4.0	AIAS00220
25.0	33.0	25.5	27.0	4.8	21.0	2.0	4.0	AIAS00250
30.0	40.0	30.6	32.0	6.0	26.0	2.0	5.0	AIAS00300
32.0	42.0	32.6	34.0	6.0	28.0	2.0	5.0	AIAS00320
35.0	45.0	35.6	37.0	6.0	31.0	2.0	5.0	AIAS00350
36.0	46.0	36.6	38.0	6.0	32.0	2.0	5.0	AIAS00360
40.0	50.0	40.6	42.0	6.0	36.0	2.0	5.0	AIAS00400
50.0	60.0	50.6	52.0	6.0	46.0	2.0	5.0	AIAS00500



■ Wear ring in modified POM for piston and rod

Description

The wear ring has the twin function of guiding the piston or the rod in a cylinder and of absorbing transversal forces in it.

At the same time, the metal contact between the sliding parts of the cylinder (piston and bore or cylinder rod and cylinder head) must be avoided.

The wear ring in modified POM material has been specifically designed for the use on such pneumatic cylinders.

The ring is available for a wide range of standard dimensions (see tables XXXIX and XXXVIII, page 56 and 59). Other dimensions are available on request.

The TSS Serial No. for wear rings in modified POM are listed in the following table.

Table XXXVII TSS Serial numbers for injection molded wear rings in modified POM

Piston TSS Serial No.	Rod TSS Serial No.	Groove width L ₂	Ring thickness W
GP41	GR41	2.50	1.55
GP43	GR43	4.00	1.55
GP48	GR48	8.20	2.00
GP49	GR49	9.70	2.00
GP51	GR51	10.00	2.00
GP53	GR53	15.00	2.00
GP54	GR54	20.00	2.00
GP55	GR55	25.00	2.00
GP56	GR56	30.00	2.00

Other materials and dimensions available - see also "Hydraulic catalogue chapt. Slydrings" or ask TSS.

All wear guide rings have chamfered edges, in order to avoid undesired edge forces in the corner radii of the grooves.

The choice for the correct size of the ring can be based on the following formula:

$$h = \frac{F \times f}{d \times p}$$

where the meaning of the letters are the following:

p = admissible pressure

F = radial load

f = safety factor

d = average guide diameter

h = guide width

Material

POTBW

This compound in polyacetal was specifically formulated for pneumatic cylinders made in aluminium.

Advantages:

- Good price/performance ratio
- High compressive strength
- Very good sliding effect in dry conditions
- Good resistance to abrasion
- Low stick-slip effect
- Simple installation also in closed grooves
- Long life



Fields of application

Speed: Up to 1 m/s, with reciprocating movements.

Temperature: from -40 °C to +110 °C

Calculation value:
Static compressive strength: max. 36.3 N/mm² at room temperature.

The load capacity for dynamic applications most depends on the operating temperature, which, therefore, should not exceed 90 °C.



Wear Ring

Installation recommendation, wear ring for piston

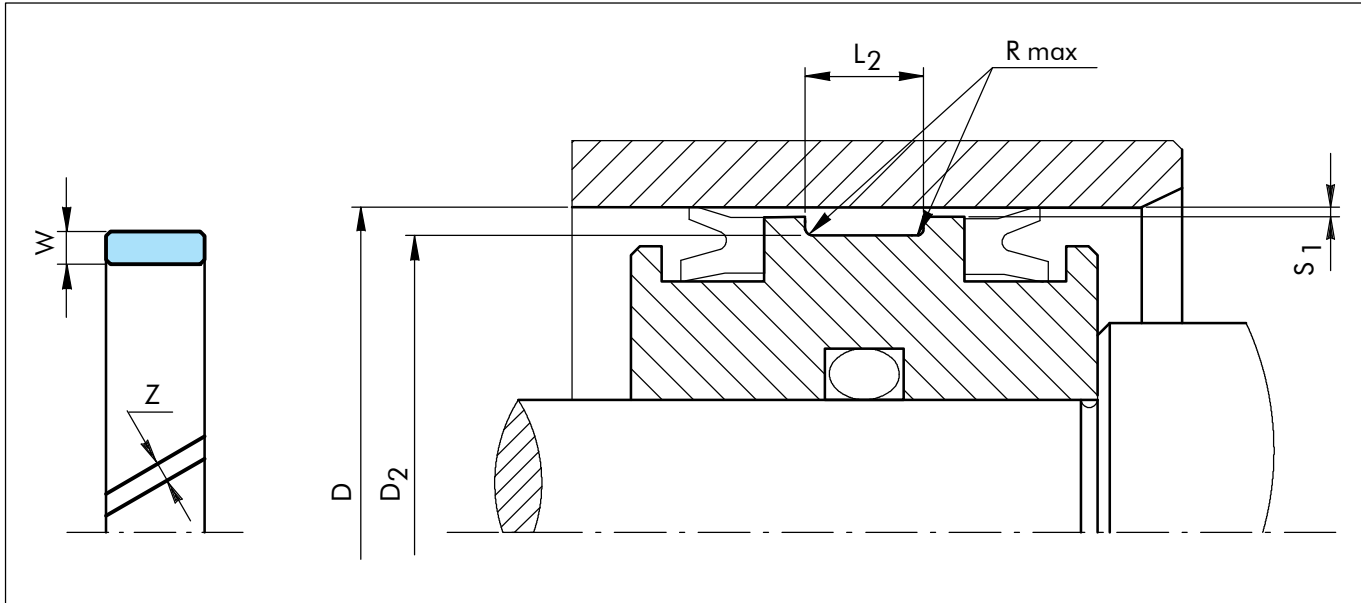

Figure 23 Installation drawing

Table XXXVIII Installation dimensions

TSS Serial No.	Bore diameter ¹⁾	Groove diameter	Groove width	Radial clearance	Ring thickness	Ring gap
	D H9	D ₂ h8	L ₂ +0.2	S ₁ ²⁾	W	Z
GP41	8 - 20,0	D -3.10	2,50	0.20 - 0.30	1.55	1 - 3
GP43	10 - 50.0	D -3.10	4.00	0.20 - 0.40	1.55	2 - 4
GP48	20 - 40.0	D -4.00	8.20	0.20 - 0.40	2.00	1 - 3
GP49	16 - 20.0	D -4.00	9.70	0.20 - 0.50	2.00	1 - 3
GP51	45 - 70.0	D -4.00	10.00	0.30 - 0.50	2.00	1 - 3
GP53	75 - 100.0	D -4.00	15.00	0.30 - 0.50	2.00	1 - 3
GP54	105 - 140.0	D -4.00	20.00	0.30 - 0.50	2.00	2 - 4
GP55	150 - 200.0	D -4.00	25.00	0.30 - 0.60	2.00	3 - 5
GP56	220 - 250.0	D -4.00	30.00	0.30 - 0.60	2.00	4 - 6

¹⁾ Recommended diameter ranges ²⁾ Specifications valid only in the area of the wear rings.

Table XXXIX Recommended radii for groove diameter

D	R max.
8 -250	0.2
>250	0.4

Table XXXX Surface roughness

Parameter	Mating surface μm	Groove surface μm
R max.	1.00 - 4.00	< 16.0
R _Z DIN	0.63 - 2.50	< 10.0
R _a	0.10 - 0.40	< 2.5



Table XXXXI Wear ring for piston

Bore diameter	Groove diameter	Groove width	Thickness	TSS Part No.
D H9	D ₂ h8	L ₂ +0.2	W	
8.0	4.9	2.5	1.55	GP4100080
10.0	6.9	2.5	1.55	GP4100100
10.0	6.9	4.0	1.55	GP4300100
12.0	8.9	4.0	1.55	GP4300120
14.0	10.9	4.0	1.55	GP4300140
15.0	11.9	4.0	1.55	GP4300150
16.0	12.9	4.0	1.55	GP4300160
16.0	12.0	9.7	2.00	GP4900160
18.0	14.9	4.0	1.55	GP4300180
18.0	14.0	9.7	2.00	GP4900180
20.0	16.9	4.0	1.55	GP4300200
20.0	16.0	8.2	2.00	GP4800200
20.0	16.0	9.7	2.00	GP4900200
22.0	18.0	9.7	2.00	GP4900220
25.0	21.9	4.0	1.55	GP4300250
25.0	21.0	8.2	2.00	GP4800250
30.0	26.0	8.2	2.00	GP4800300
32.0	28.9	4.0	1.55	GP4300320
32.0	28.0	8.2	2.00	GP4800320
35.0	31.0	8.2	2.00	GP4800350
40.0	36.0	8.2	2.00	GP4800400
45.0	41.0	10.0	2.00	GP5100450
50.0	46.0	9.7	2.00	GP4900500
50.0	46.0	10.0	2.00	GP5100500
55.0	51.0	9.7	2.00	GP4900550
55.0	51.0	10.0	2.00	GP5100550
58.0	54.0	10.0	2.00	GP5100580
60.0	56.0	9.7	2.00	GP4900600
60.0	56.0	10.0	2.00	GP5100600
63.0	59.0	10.0	2.00	GP5100630
65.0	61.0	9.7	2.00	GP4900650
65.0	61.0	10.0	2.00	GP5100650
70.0	66.0	10.0	2.00	GP5100700
75.0	71.0	9.7	2.00	GP4900750
75.0	71.0	15.0	2.00	GP5300750
80.0	76.0	9.7	2.00	GP4900800
80.0	76.0	10.0	2.00	GP5100800
80.0	76.0	15.0	2.00	GP5300800
85.0	81.0	9.7	2.00	GP4900850
85.0	81.0	15.0	2.00	GP5300850
90.0	86.0	15.0	2.00	GP5300900
95.0	91.0	15.0	2.00	GP5300950
100.0	96.0	9.7	2.00	GP4901000
100.0	96.0	10.0	2.00	GP5101000
100.0	96.0	15.0	2.00	GP5301000



Wear Ring

Bore diameter	Groove diameter	Groove width	Thickness	TSS Part No.
D H9	D ₂ h8	L ₂ +0.2	W	
105.0	101.0	20.0	2.00	GP5401050
110.0	106.0	20.0	2.00	GP5401100
115.0	111.0	20.0	2.00	GP5401150
120.0	116.0	20.0	2.00	GP5401200
125.0	121.0	15.0	2.00	GP5301250
125.0	121.0	20.0	2.00	GP5401250
130.0	126.0	20.0	2.00	GP5401300
135.0	131.0	20.0	2.00	GP5401350
140.0	136.0	20.0	2.00	GP5401400
150.0	146.0	25.0	2.00	GP5501500
160.0	156.0	15.0	2.00	GP5301600
180.0	176.0	25.0	2.00	GP5501800
200.0	196.0	20.0	2.00	GP5402000
200.0	196.0	25.0	2.00	GP5502000
220.0	216.0	30.0	2.00	GP5602200
250.0	246.0	20.0	2.00	GP5402500
250.0	246.0	30.0	2.00	GP5602500

Ordering example

Wear ring for piston, diameter D = 20.00 mm
 Series GP49 from Table XXXVIII, page 58
 Groove width: 9.70 mm, ring thickness: 2.00 mm

Material: POTBW

TSS Article No.: GP4900200
 (from Table XXXI, page 59)

TSS Article No.	GP49	0	0200	POTBW
TSS Series No.				
Design code (standard)				
Piston diameter x 10				
Material code:				

For all intermediate dimensions not listed in table XXXIX, the TSS Article No. can be formed from the example.



■ Installation recommendation, wear ring for rod

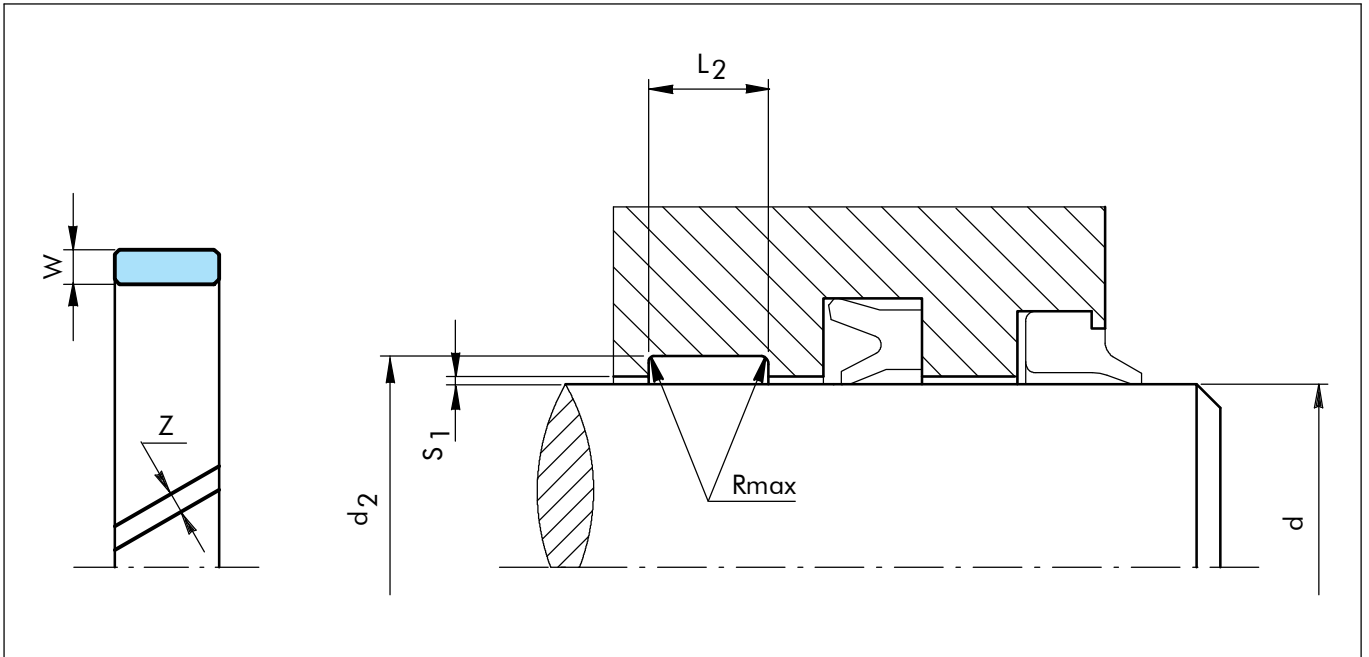

Figure 24 Installation drawing

Table XXXXII Installation dimensions

TSS Serial No.	Rod diameter ¹⁾	Groove diameter	Groove width	Radial clearance	Ring thickness	Ring gap
	d f8/h9	d_2 H8	$L_2 + 0.2$	S_1 ²⁾	W	Z
GR41	8 - 20.0	$d + 3.10$	2.50	0.20 - 0.30	1.55	1 - 3
GR43	10 - 50.0	$d + 3.10$	4.00	0.20 - 0.40	1.55	2 - 4
GR49	16 - 20.0	$d + 4.00$	9.70	0.20 - 0.50	2.00	1 - 3

1) Recommended diameter ranges

2) Specifications valid only in the area of the wear rings

Table XXXXIII Recommended radii for groove diameter

D	R max.
8 - 250	0.2
>250	0.4

Table XXXXIV Surface roughness

Parameter	Mating surface μm	Groove surface μm
R max.	1.00 - 4.00	< 16.0
RZ DIN	0.63 - 2.50	< 10.0
Ra	0.10 - 0.40	< 2.5



Wear Ring

Table XXXXV Wear ring for rod

Rod diameter	Groove diameter	Groove width	thickness	TSS Part No.
d f8/h9	d2 H8	L2 +0.2	W	
8.0	11.1	2.5	1.55	GR4100080
10.0	13.1	2.5	1.55	GR4100100
10.0	13.1	4.0	1.55	GR4300100
12.0	15.1	4.0	1.55	GR4300120
12.0	16.0	9.7	2.00	GR4900120
14.0	17.1	4.0	1.55	GR4300140
14.0	18.0	9.7	2.00	GR4900140
15.0	18.1	4.0	1.55	GR4300150
16.0	19.1	4.0	1.55	GR4300160
16.0	20.0	9.7	2.00	GR4900160
18.0	21.1	4.0	1.55	GR4300180
18.0	22.0	9.7	2.00	GR4900180
20.0	23.1	4.0	1.55	GR4300200
22.0	25.1	4.0	1.55	GR4300220
25.0	28.1	4.0	1.55	GR4300250
28.0	31.1	4.0	1.55	GR4300280
30.0	33.1	4.0	1.55	GR4300300
32.0	35.1	4.0	1.55	GR4300320
35.0	38.1	4.0	1.55	GR4300350
35.0	39.0	9.7	2.00	GR4900350
36.0	39.1	4.0	1.55	GR4300360
40.0	43.1	4.0	1.55	GR4300400
40.0	44.0	9.7	2.00	GR4900400
45.0	49.0	9.7	2.00	GR4900450
46.0	60.0	9.7	2.00	GR4900460
50.0	53.1	4.0	1.55	GR4300500
50.0	54.0	9.7	2.00	GR4900500
55.0	59.0	9.7	2.00	GR4900550
60.0	64.0	9.7	2.00	GR4900600



Ordering example

Wear ring for rod, diameter $d = 16.00$ mm
Series GR43 from Table XXXII, page 61
Groove width: 4.00 mm, ring thickness: 1.55 mm

Material: POTBW

TSS Article No.: GR4300160 (from Table XXXV, page 62)

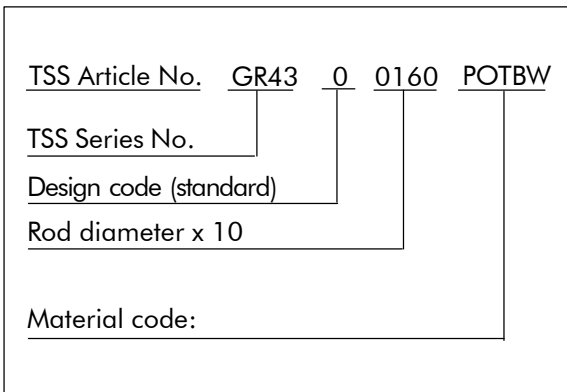

For all intermediate dimensions not listed in table XXXIII, the TSS Article No. can be formed from the example.



Static Seal - Type DRV4

Static Seal type DRV4

Description

The DRV4-seal is a static operating seal ring developed for pneumatic applications. It is a 2-component-injection-molding part (plastics / polyurethane).

DRV4-seal is conform according ISO 16030 and achieves the following properties:

- captive on thread (triple-lug principle)
- reusable (up to 5 - 10 x)
- capable of providing long-term performance

In addition DRV4 offers more advantages:

- close by hand-torque
- no corrosion, because plastics-polyurethane-bonded
- long-time tight
- excellent automatically mountable
- lightweight

Technical data

Operating pressure: 1.0 MPa
 Temperature: -10 °C to +60 °C

Material

basic ring: PA, grey
 seal: TPU, black

Installation

The seal has only to be fitted on the threaded bolt. If the bolted connection is tightened the sealing lip is pressed against the flat surfaces. The thickness of the basic ring limits the compression of the elastomer seal. Sealing effects will already be achieved by hand-torque.

Ordering example

Static Seal,
 type DRV4
 Thread diameter: 1/2 "
 TSS Part No.: DRV401270 (Table XXXXVI)
 Material No.: U8XPA

TSS Article No.	DRV4	01270	-	U8XPA
TSS Series No.				
Dimension				
Material No.:				

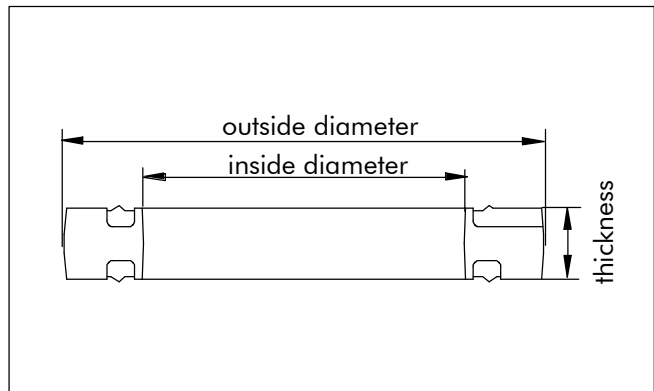

Figure 25

Further solutions for static applications:

Please see also O-Ring catalogue or Static Seal catalogue.

Static Seal - Type DRV4



Table XXXXVI

Size	Inside diameter	Outside diameter	Thickness	TSS Article No.
1/8 inch	9.90 mm +0.05/-0.05	13.15 mm +0.05/-0.05	1.60 mm +0.05/-0.05	DRV400990-U8XPA
1/4 inch	13.30 mm +0.05/-0.05	18.15 mm +0.05/-0.05	2.20 mm +0.05/-0.05	DRV401330-U8XPA
3/8 inch	16.80 mm +0.05/-0.05	22.15 mm +0.05/-0.05	2.20 mm +0.05/-0.05	DRV401680-U8XPA
1/2 inch	21.20 mm +0.05/-0.05	26.45 mm +0.05/-0.05	2.35 mm +0.05/-0.05	DRV402120-U8XPA
3/4 inch	26.70 mm +0.05/-0.05	32.45 mm +0.05/-0.05	2.95 mm +0.05/-0.05	DRV402670-U8XPA

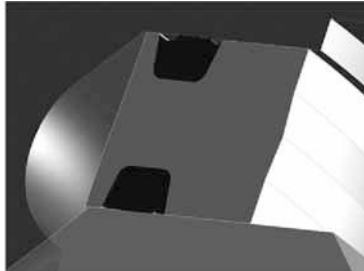

LOCAL CONTACTS

EUROPE

Austria – Vienna (Slovenia)

+43 (0) 1 406 47 33

Belgium - Dion-Valmont (Luxembourg)

+32 (0) 10 22 57 50

Bulgaria – Sofia

(Azerbaijan, Belarus, Greece, Romania, Ukraine)

+359 (0) 2 969 95 99

Croatia – Zagreb (Albania, Bosnia and Herzegovina,

Macedonia, Serbia, Montenegro)

+385 (0) 1 24 56 387

Czech Republic - Rakovnik (Slovakia)

+420 313 529 111

Denmark – Copenhagen

+45 48 22 80 80

Finland – Vantaa (Estonia, Latvia)

+358 (0) 207 12 13 50

France - Maisons-Laffitte

+33 (0) 1 30 86 56 00

Germany - Stuttgart

+49 (0) 711 7864 0

Hungary – Budaörs

+36 (06) 23 50 21 21

Italy – Livorno

+39 0586 22 6111

The Netherlands - Rotterdam

+31 (0) 10 29 22 111

Norway – Oslo

+47 22 64 60 80

Poland – Warsaw (Lithuania)

+48 (0) 22 863 30 11

Russia – Moscow

+7 495 627 57 22

Spain – Madrid (Portugal)

+34 (0) 91 71057 30

Sweden – Jönköping

+46 (0) 36 34 15 00

Switzerland – Crissier

+41 (0) 21 631 41 11

Turkey – Istanbul

+90 216 569 73 00

United Kingdom - Solihull (Eire, South Africa)

+44 (0) 121 744 1221

Aerospace Hub Europe, North

(UK and Nordic Countries)

+44 (0) 121 744 1221

Aerospace Hub Europe, South & West

(Continental Europe and Middle East)

+33 (0) 1 30 86 56 00

Automotive Hub Europe

+49 (0) 711 7864 0

AMERICAS

Americas Regional

+1 260 749 9631

Brazil – São José dos Campos

+55 12 3932 7600

Canada Central – Etobicoke, ON

+1 416 213 9444

Canada East – Montreal, QC

+1 514 284 1114

Canada West – Langley, BC

+1 604 539 0098

Mexico - Mexico City

+52 55 57 19 50 05

USA, Great Lakes - Fort Wayne, IN

+1 260 482 4050

USA, East - Mt. Juliet, TN

+1 615 800 8340

USA, Midwest - Schaumburg, IL

+1 630 539 5500

USA, Northern California - Fresno, CA

+1 559 449 6070

USA, Northwest - Portland, OR

+1 503 595 6565

USA, Southwest - Houston, TX

+1 713 461 3495

Aerospace Hub Airframe

+1 303 469 1357

Aerospace Hub Distribution & Engineering

+1 260 749 9631

Aerospace Hub East

+1 610 828 3209

Aerospace Hub West

+1 310 371 1025

Automotive Hub North America

+1 734 354 1250

Automotive Hub South America

+55 12 3932 7600

ASIA PACIFIC

Asia Pacific Regional

+65 6 577 1778

China – Hong Kong

+852 2366 9165

China – Shanghai

+86 (0) 21 6145 1830

India – Bangalore

+91 (0) 80 3372 9000

Japan – Tokyo

+81 (0) 3 5633 8008

Korea – Seoul

+82 (0) 2 761 3471

Malaysia - Kuala Lumpur

+60 (0) 3 90549266

Taiwan – Taichung

+886 4 2382 8886

Vietnam – Ho Chi Minh City

+84 8 6288 6407

Singapore and all other countries in South

and East Asia, Australasia

+65 6 577 1778

Aerospace Hub China

+86 (0) 21 6145 1830

Aerospace Hub Singapore

+65 6 577 1778

Automotive Hub China

+86 (0) 21 6145 1830

Automotive Hub India

+91 (0) 80 3372 9200

AFRICA, CENTRAL ASIA AND MIDDLE EAST

Africa & Iran (excluding South Africa (see UK))

+41 (0) 21 631 41 11

Central Asia (Armenia, Georgia, Kazakhstan,

Kyrgyzstan, Tajikistan, Uzbekistan)

+7 495 627 57 22

Middle East and Gulf Region

+359 (0) 2 969 95 99



Trelleborg is a world leader in engineered polymer solutions that seal, damp and protect critical applications in demanding environments. Its innovative engineered solutions accelerate performance for customers in a sustainable way. The Trelleborg Group has local presence in over 40 countries around the world.



facebook.com/TrelleborgSealingSolutions

twitter.com/TrelleborgSeals

youtube.com/TrelleborgSeals

flickr.com/TrelleborgSealingSolutions



WWW.TSS.TRELLEBORG.COM